

Section C9

Electrical Wiring Diagrams

The electrical components related to the automatic air conditioning system are contained within Section C8 of Chapter C.

This section contains the following theoretical and practical wiring diagrams applicable to the automatic air conditioning system.

Figure Number	Title
C57	Theoretical wiring diagram (Automatic Air Conditioning System)
C58	Practical wiring diagram (Automatic Air Conditioning System)
C59	Interlock circuit
C60	Inhibit circuit
C61	Function switch
C62	Temperature sensors and selectors circuit
C63	Temperature sensors resistance values
C64	Recirculation actuators circuit
C65	Lower quantity flap actuator circuit
C66	Mode flap actuator circuit
C67	Voltage stabilizer wiring
C68	Fan motors circuit

Switching sequence

Switch position	Contacts made
OFF	1-2 9-10 11-12
LOW	1-3 4-14 9-10 11-12
AUTO	1-3 5-6 9-10 11-12
HIGH	1-3 7-14 9-10 11-12
DE-ICE	1-3 1-13 8-14

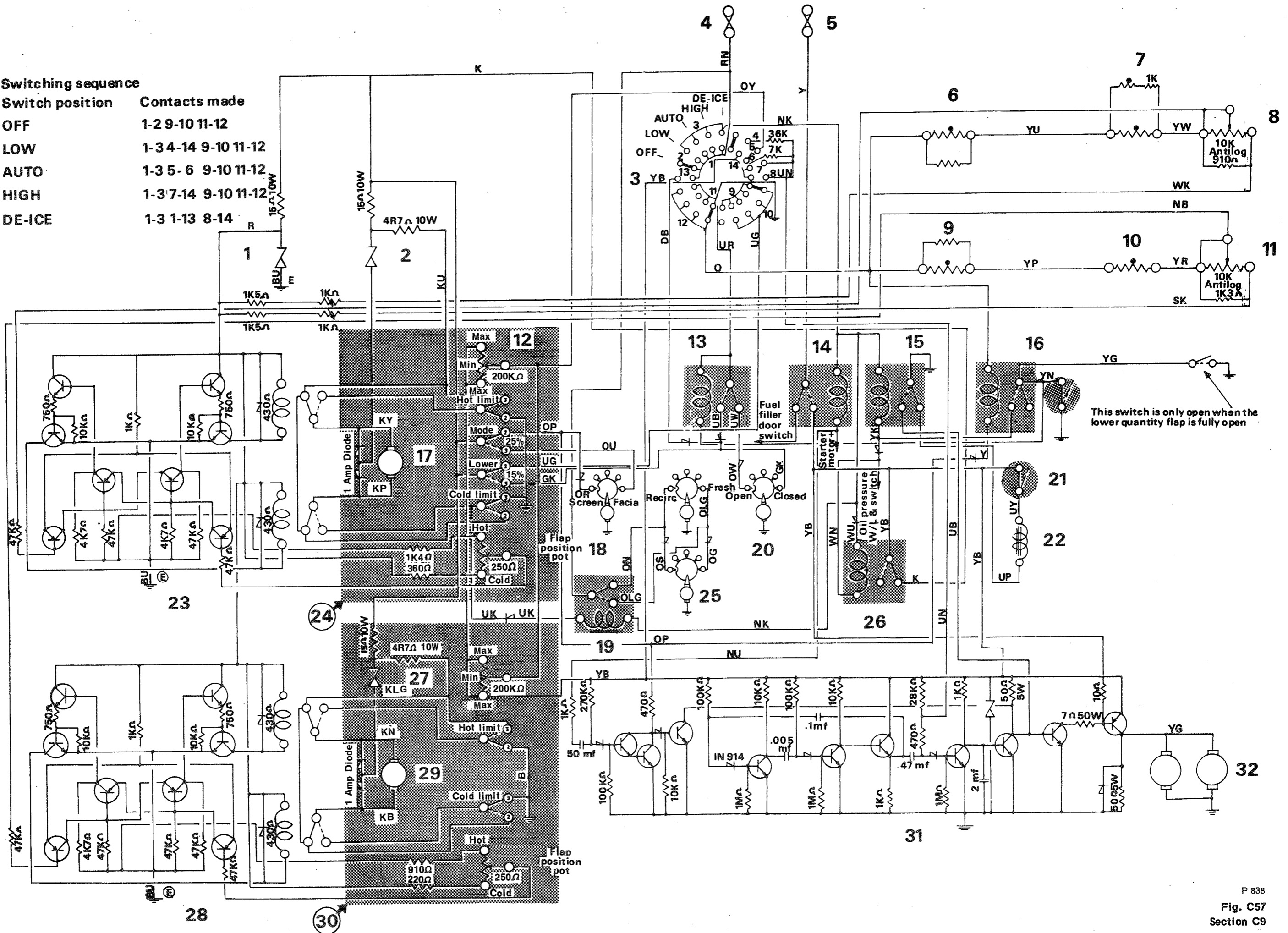

This switch is only open when the lower quantity flap is fully open

Fig. C57

Theoretical Wiring Diagram

- 1 Electronics stabilizer
- 2 Upper servo stabilizer
- 3 Selector switch
- 4 Ignition fuse
- 5 Fan & compressor clutch fuse
- 6 Upper air ambient sensor
- 7 Upper air saloon sensor
- 8 Upper air selector
- 9 Lower air ambient sensor
- 10 Lower air saloon sensor
- 11 Lower air selector
- 12 Fan speed potentiometer
- 13 Lower quantity actuator relay
- 14 Fan & compressor relay
- 15 Fan module switch off relay
- 16 Isolation relay and fan delay thermostat
- 17 Servo motor
- 18 Upper mode change actuator
- 19 Recirculation relay
- 20 Lower quantity override
- 21 Compressor ambient thermostat
- 22 Compressor clutch solenoid
- 23 Upper servo module
- 24 Upper servo
- 25 Recirculation actuators
- 26 Servo isolation relay
- 27 Lower servo stabilizer
- 28 Lower servo module
- 29 Servo motor
- 30 Lower servo
- 31 Fan module
- 32 Fan motors

Wiring Diagram Colour Codes

- B - Black
- R - Red
- Y - Yellow
- LG - Light Green
- S - Grey
- K - Pink
- N - Brown
- O - Orange
- G - Green
- P - Purple
- W - White
- U - Blue

Note First letter denotes the base or main colour.
Second letter denotes the tracer colour.

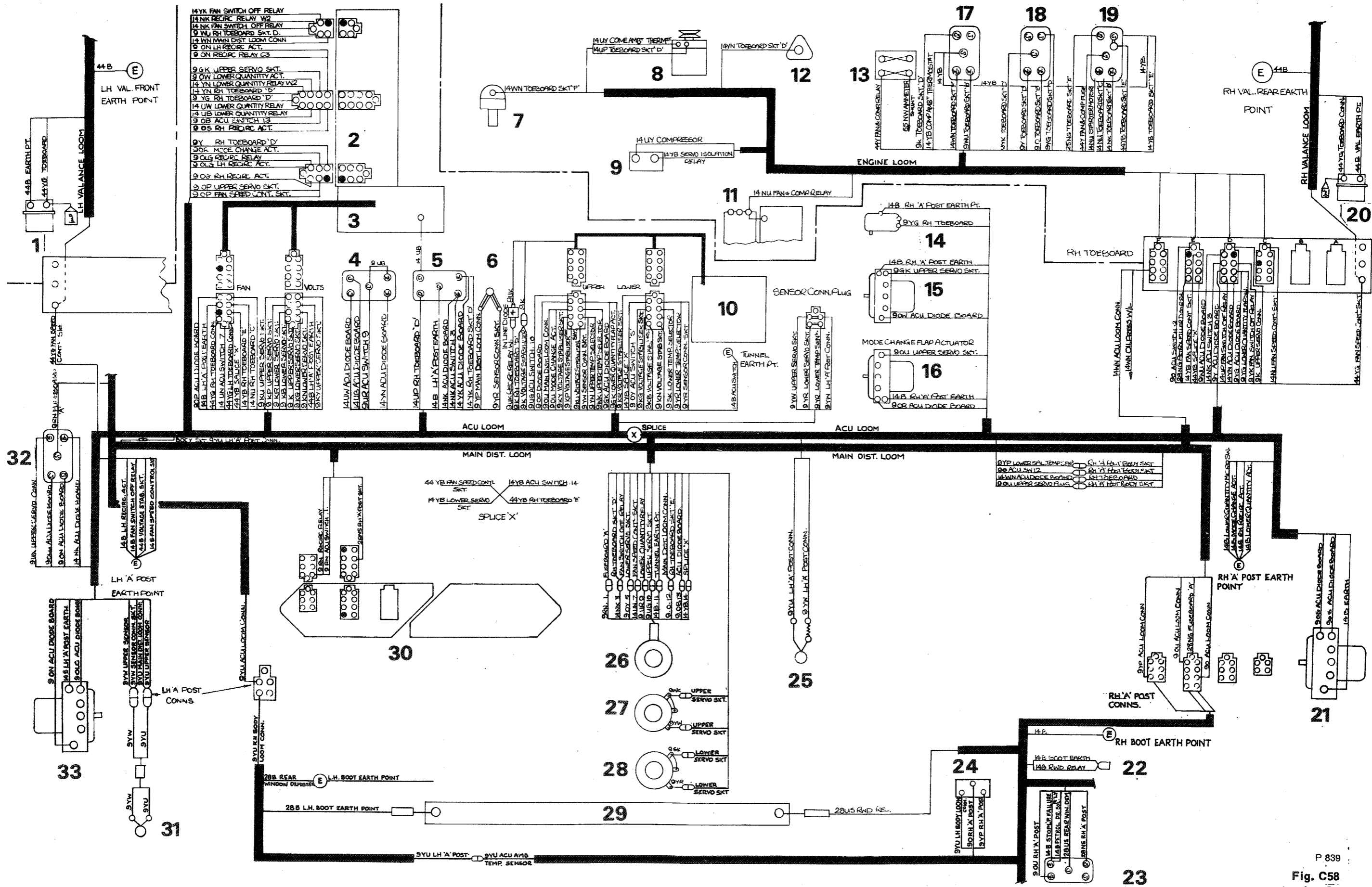

P 839
 Fig. C58
 Section C9

Fig. C58

Practical Wiring Diagram

- 1 Blower motor
- 2 A.C.U. diode board
- 3 Fan speed module and voltage stabiliser
- 4 Lower quantity actuator relay
- 5 Fan switch-off relay
- 6 Lower saloon temperature sensor
- 7 Oil pressure switch
- 8 Compressor
- 9 Compressor ambient thermostat
- 10 Servo unit
- 11 Starter motor solenoid
- 12 Fan delay thermostat
- 13 Fan and compressor fuse
- 14 Lower quantity flap micro-switch
- 15 Lower quantity flap actuator
- 16 Mode change flap actuator
- 17 Servo isolation relay
- 18 Fan delay relay
- 19 Fan and compressor relay
- 20 Blower motor
- 21 Right-hand recirculation actuator
- 22 Fuel filler door solenoid
- 23 Rear window demister relay
- 24 A.C.U. ambient temperature sensor
- 25 Upper system temperature sensor (top roll)
- 26 A.C.U. function switch
- 27 A.C.U. upper temperature switch
- 28 A.C.U. lower temperature switch
- 29 Rear window demister
- 30 Fuseboard
- 31 Upper system temperature sensor (cantrail)
- 32 Recirculation relay
- 33 Left-hand recirculation actuator

Wiring Diagram Colour Codes

- | | | |
|----|---|-------------|
| B | - | Black |
| R | - | Red |
| Y | - | Yellow |
| LG | - | Light Green |
| S | - | Grey |
| K | - | Pink |
| N | - | Brown |
| O | - | Orange |
| G | - | Green |
| P | - | Purple |
| W | - | White |
| U | - | Blue |

Note First letter denotes the base or main colour.
Second letter denotes the tracer colour.

Fig. C59

Interlock Circuit

Theoretical

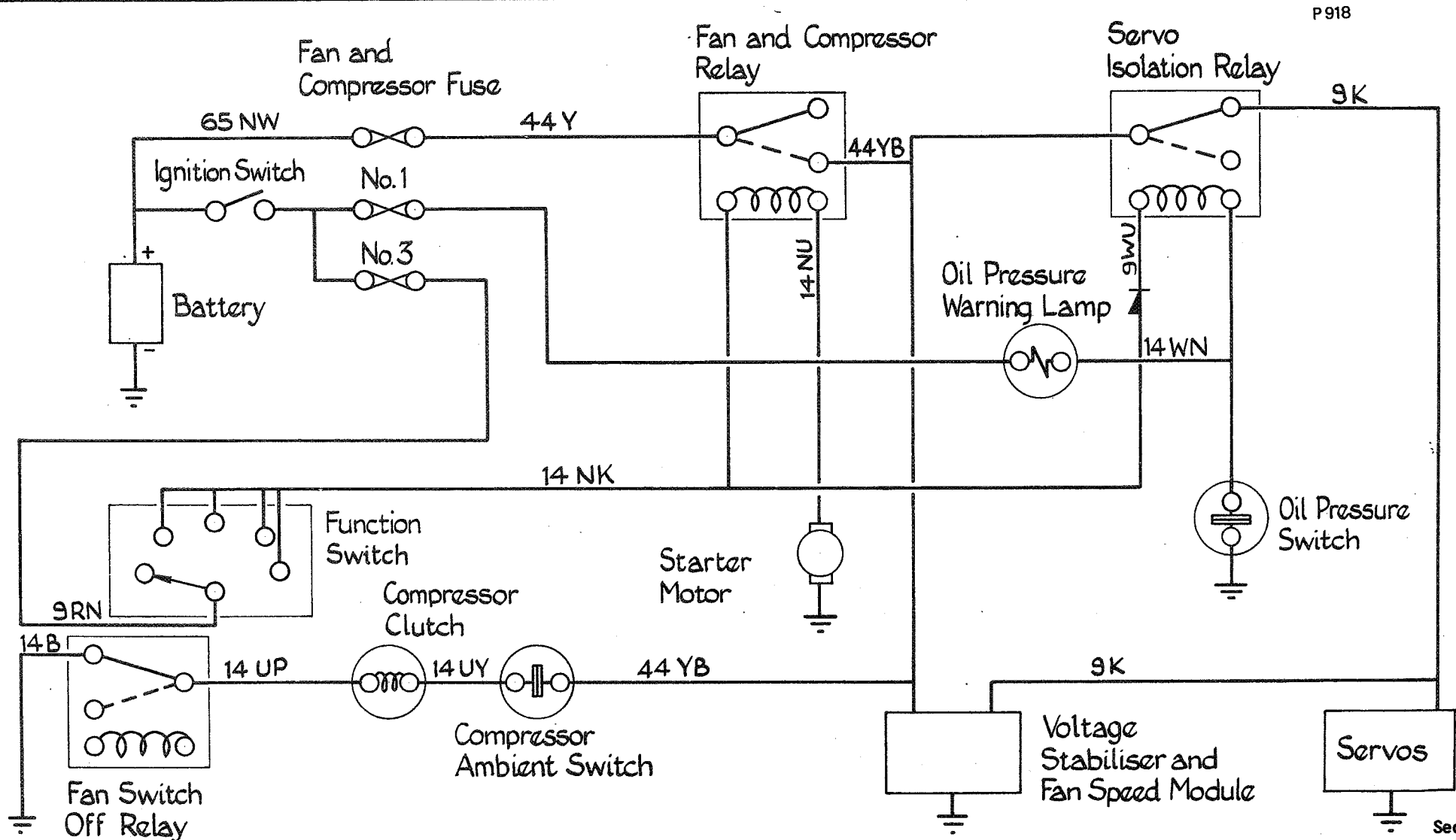

P 918

Fig. C60

Inhibit Circuit Practical

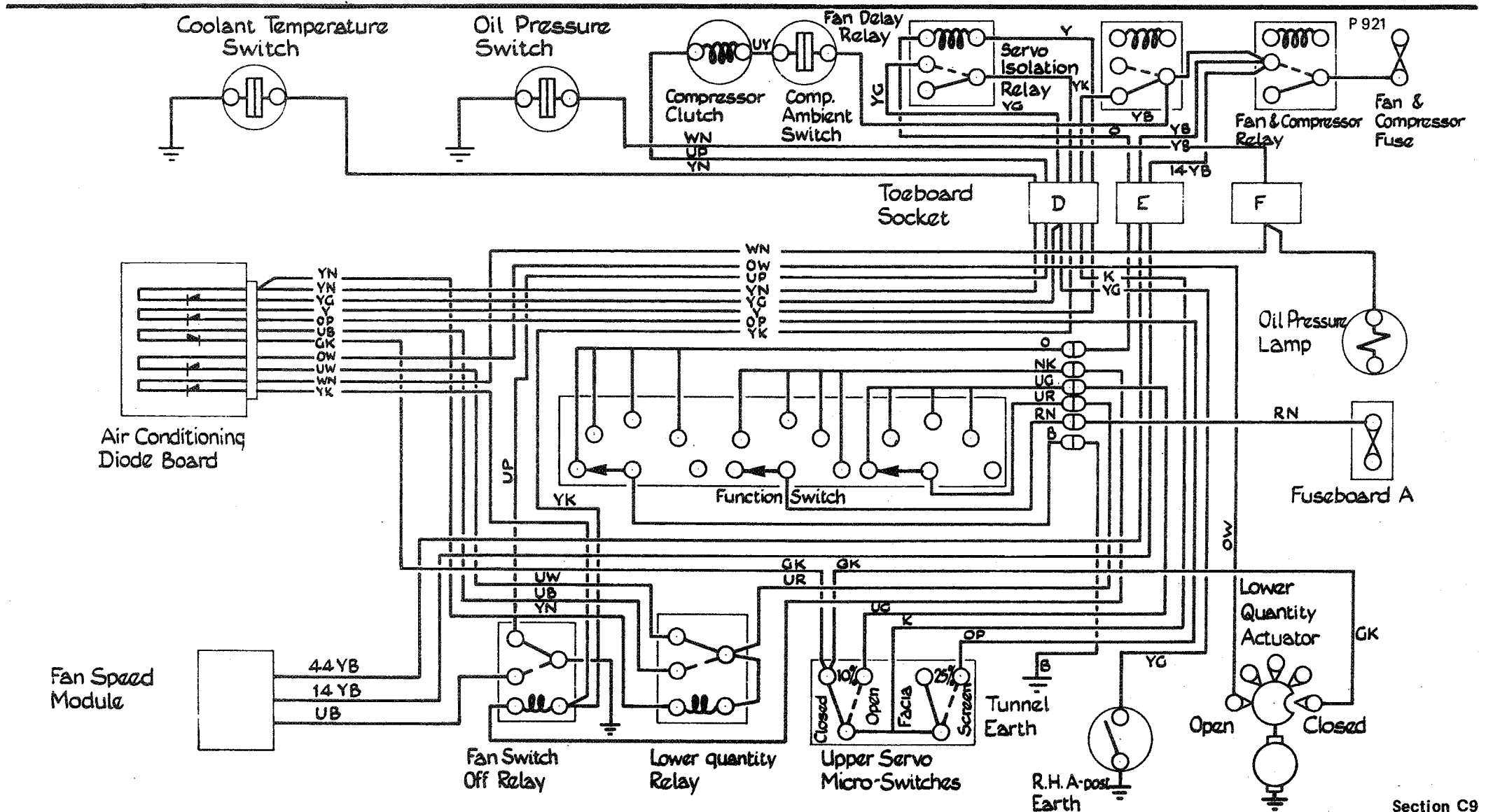
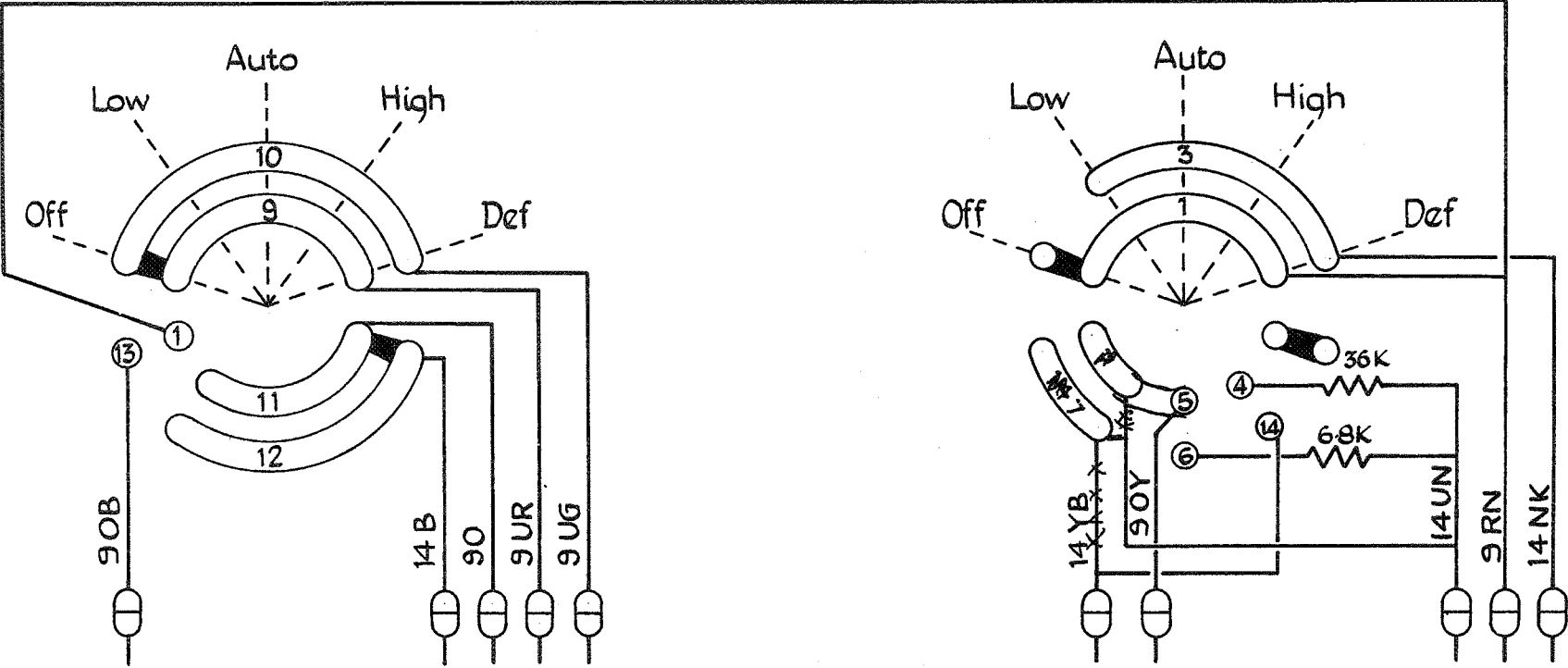

Fig. C61

Function Switch

P 922



Connection Chart

Wire Colours	9UG/9UR	9OB/9RN	14B/90	9RN/14NK	14YB/14UN	90Y/14UN
Off	Closed	Open	Closed	Open	Open	Open
Low	Closed	Open	Closed	Closed	36 K	Open
Auto	Closed	Open	Closed	Closed	Open	6.8 K
High	Closed	Open	Closed	Closed	Closed	Open
DEF	Open	Closed	Open	Closed	Closed	Open

Fig. C61

Function Switch Operation

P 912

Function Switch Control Position	Off	Low	Auto	High	Def
Fan Speed	Fans Off	Fixed Low	Infinitely Variable Automatically	Fixed ^{Auto} High	Fixed ^{Auto} High
Temperature Control	Both temp flaps are fixed at the position they occupied when switched off	Both upper and lower temperature flaps move automatically and independently			Both temp flaps move to and remain at full heat
Heater Tap		Automatically controlled by lower servo			Controlled by lower servo hence fully open
Mode Position	As when system was switched off	Facia when upper servo is at 0-25 Windscreen when upper servo is at 25-100			Windscreen
Rear Window Demister	Off ^{ON}	Off when upper servo is at 0-25 On when upper servo is at 25-100			On
Lower Quantity Flap	Closed	Closed when upper servo is at 0-10 or if engine temperature is below 50°C Otherwise open			Closed
Recirculation Flap	Recirculation	Fresh air except when upper servo is at cold limit - then 80% recirculation			Fresh
Refrigeration Compressor	Off	Operates above 0°C			
Fan Delay	Not applicable	1. 13 second delay after engine is running 2. Delayed for upper servo position of 25-100 until engine temperature reaches 40°C			Fans start immediately engine is running

44

Fig. C62

Temperature Sensor and Selector Circuit

Sensors Theoretical

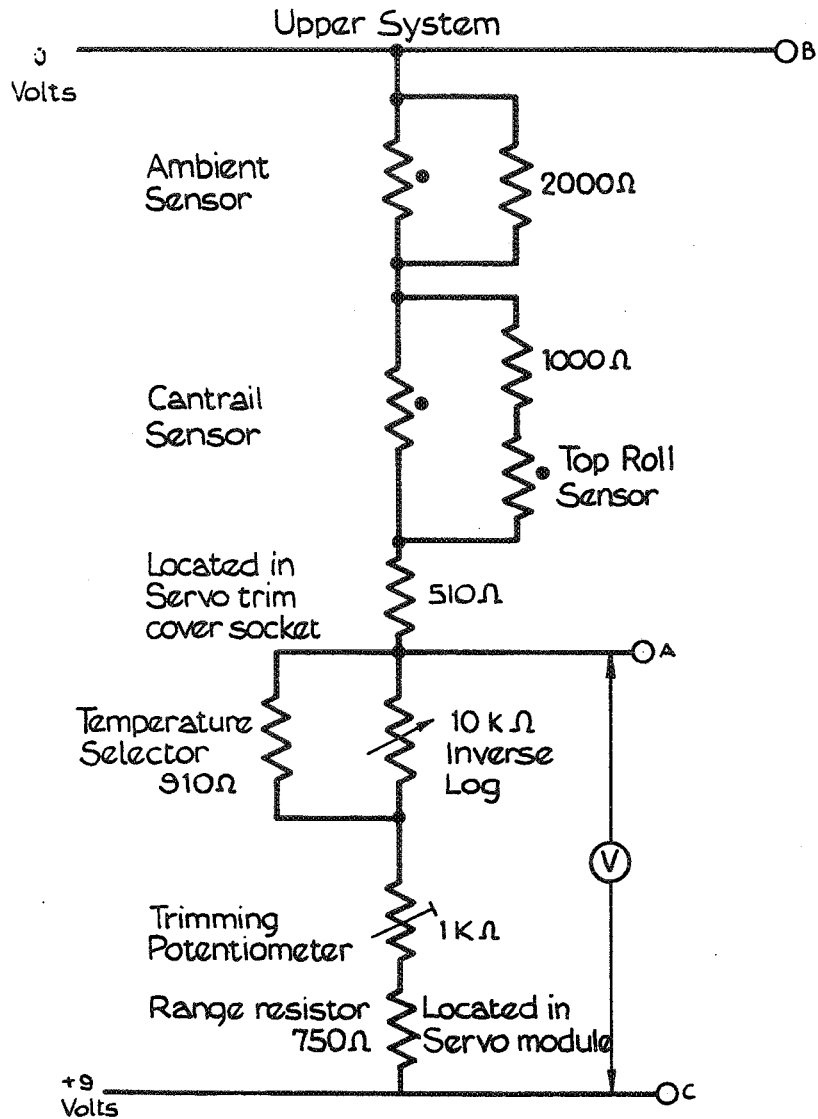

P923

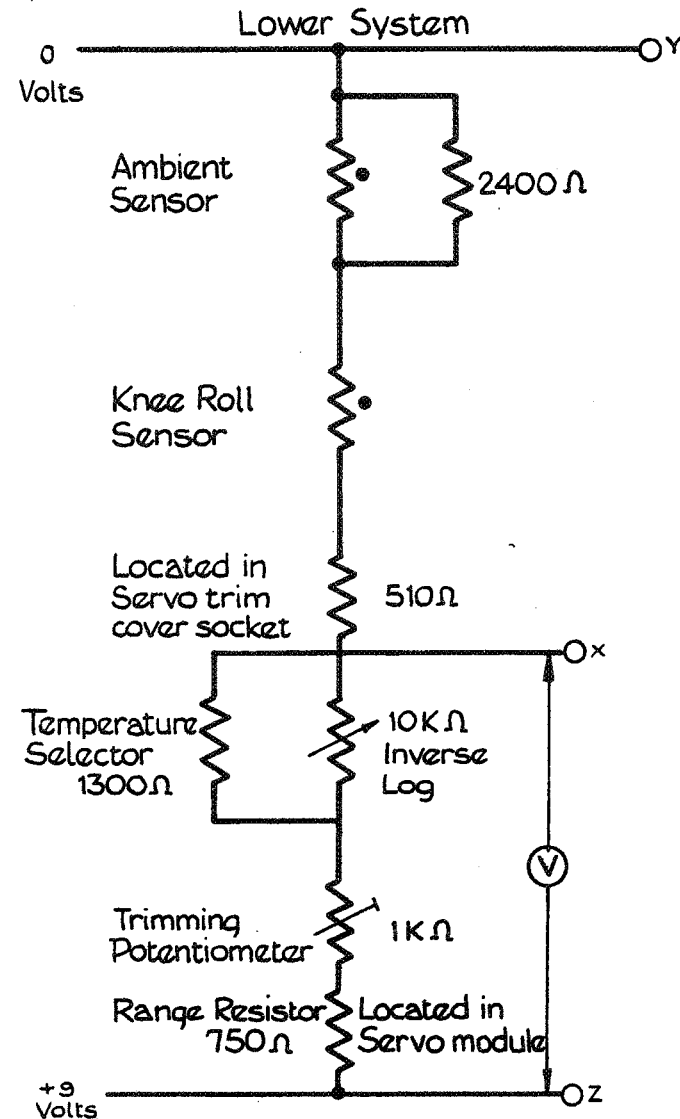

Fig. C62

Temperature Sensor and Selector Circuit Theoretical/Practical Diagram

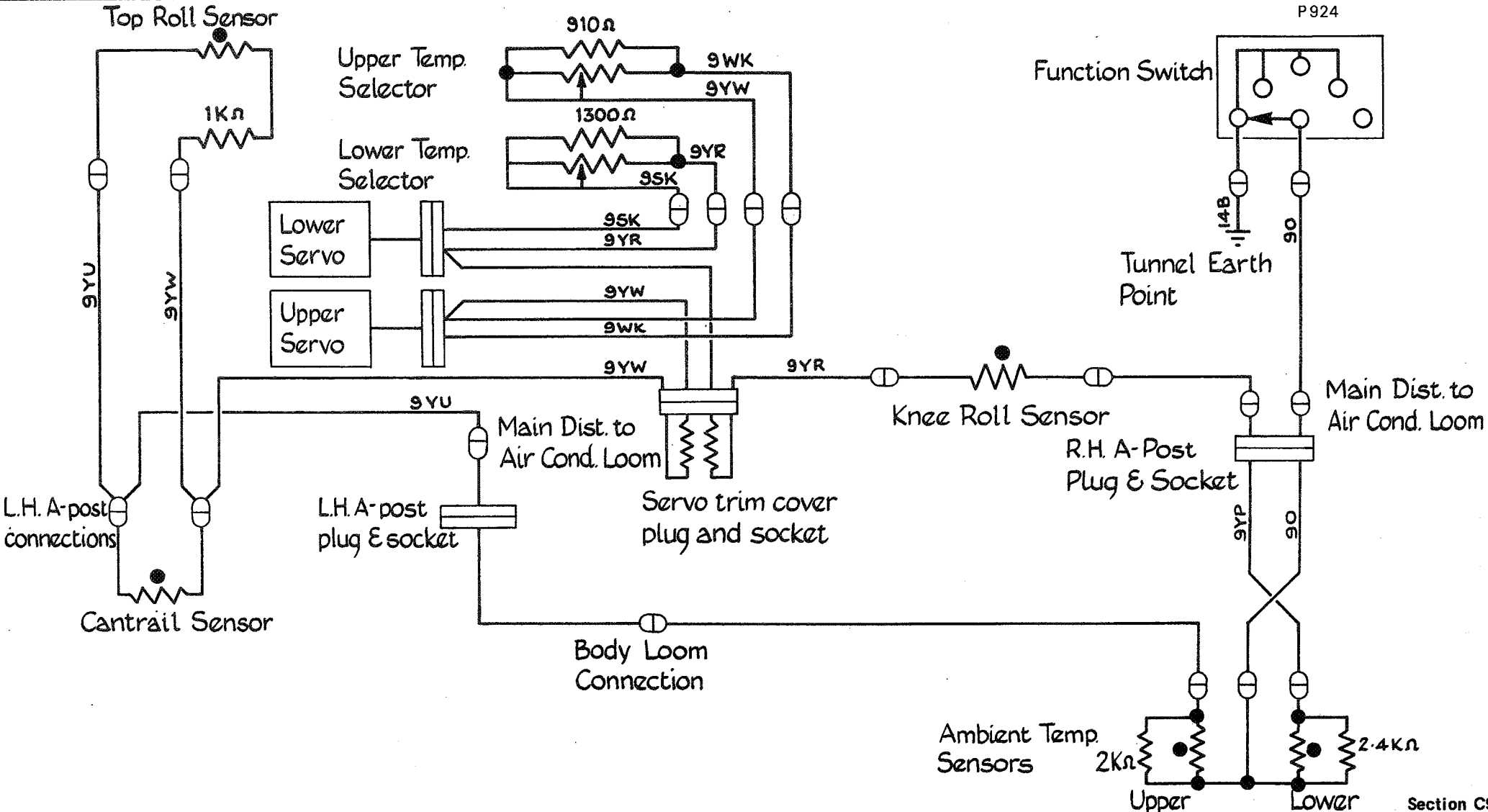
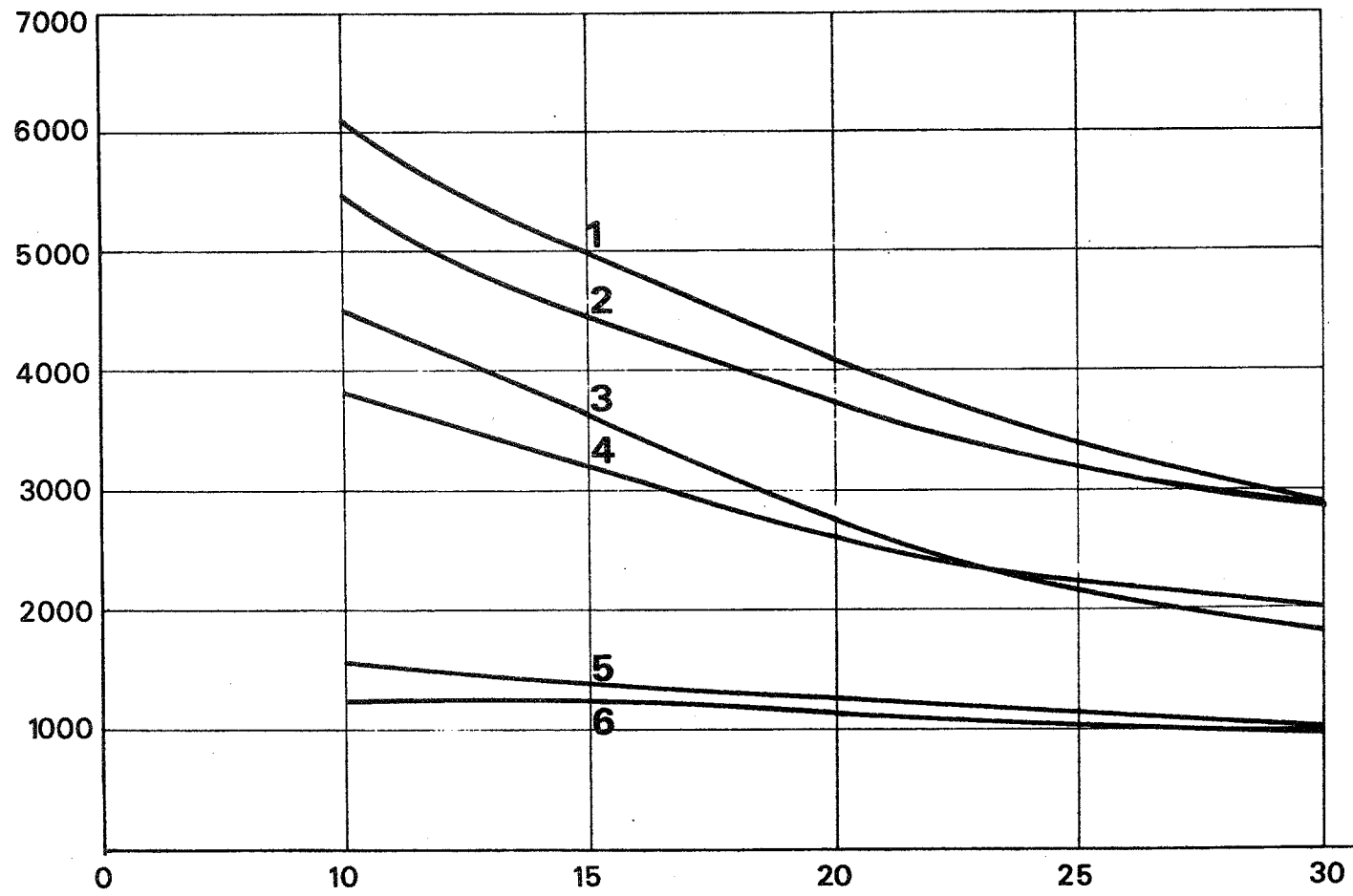

Fig. C63

Temperature Sennsor Resistances Value Sensor Resistances against Temperature

P925

Resistance Ω



- 1** Total resistance of lower sensors
- 2** Resistance of top roll sensor
- 3** Resistance of knee roll or cantrail sensor
- 4** Total resistance of upper sensors
- 5** Resistance of lower ambient sensor
- 6** Resistance of upper ambient sensor

Temperature
°C

Fig. C65

Lower Quantity Flap Actuator Circuit

Theoretical/Practical

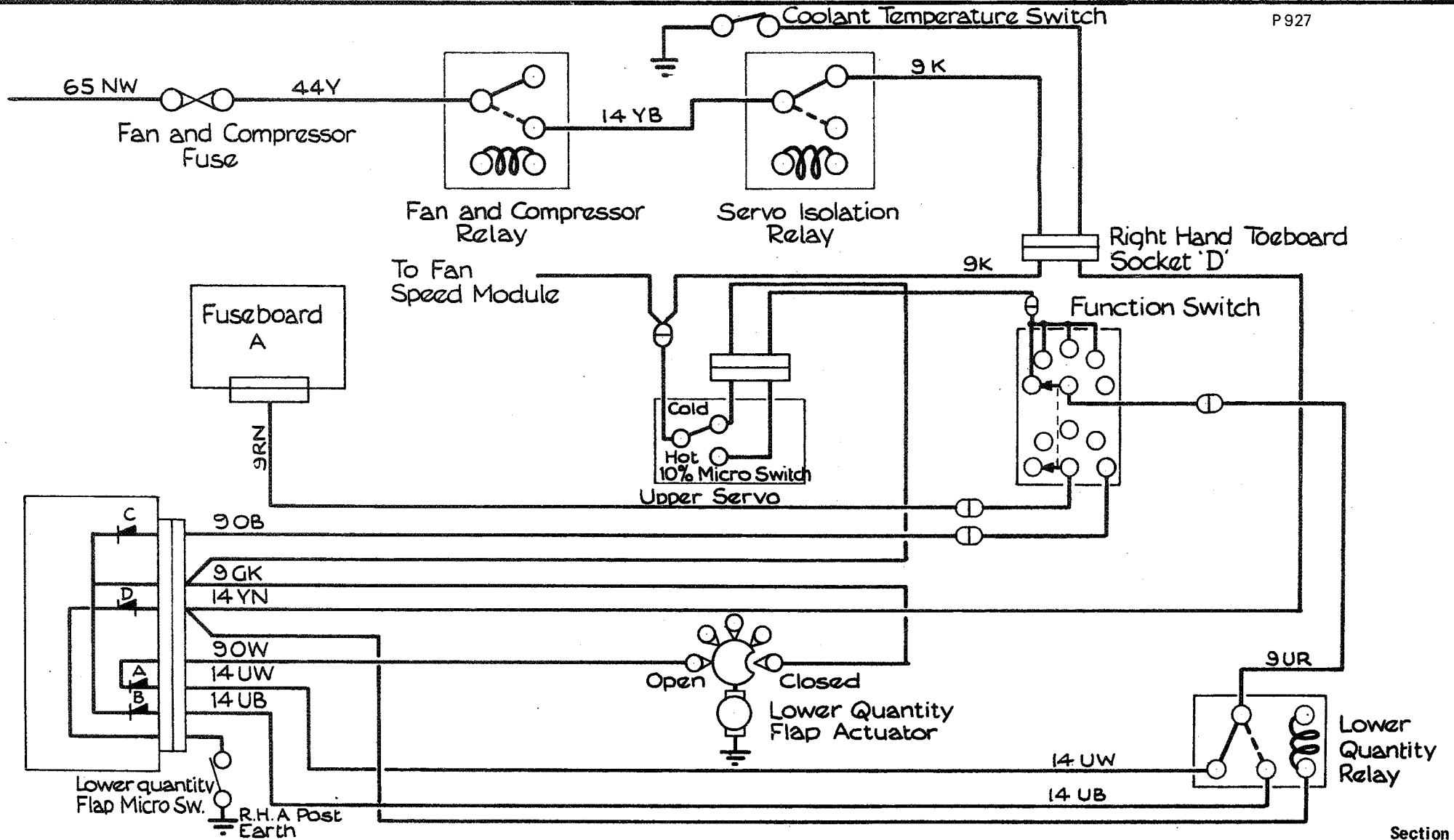

Fig. C66

Mode Flap Actuator Circuit

Theoretical/Practical

P 928

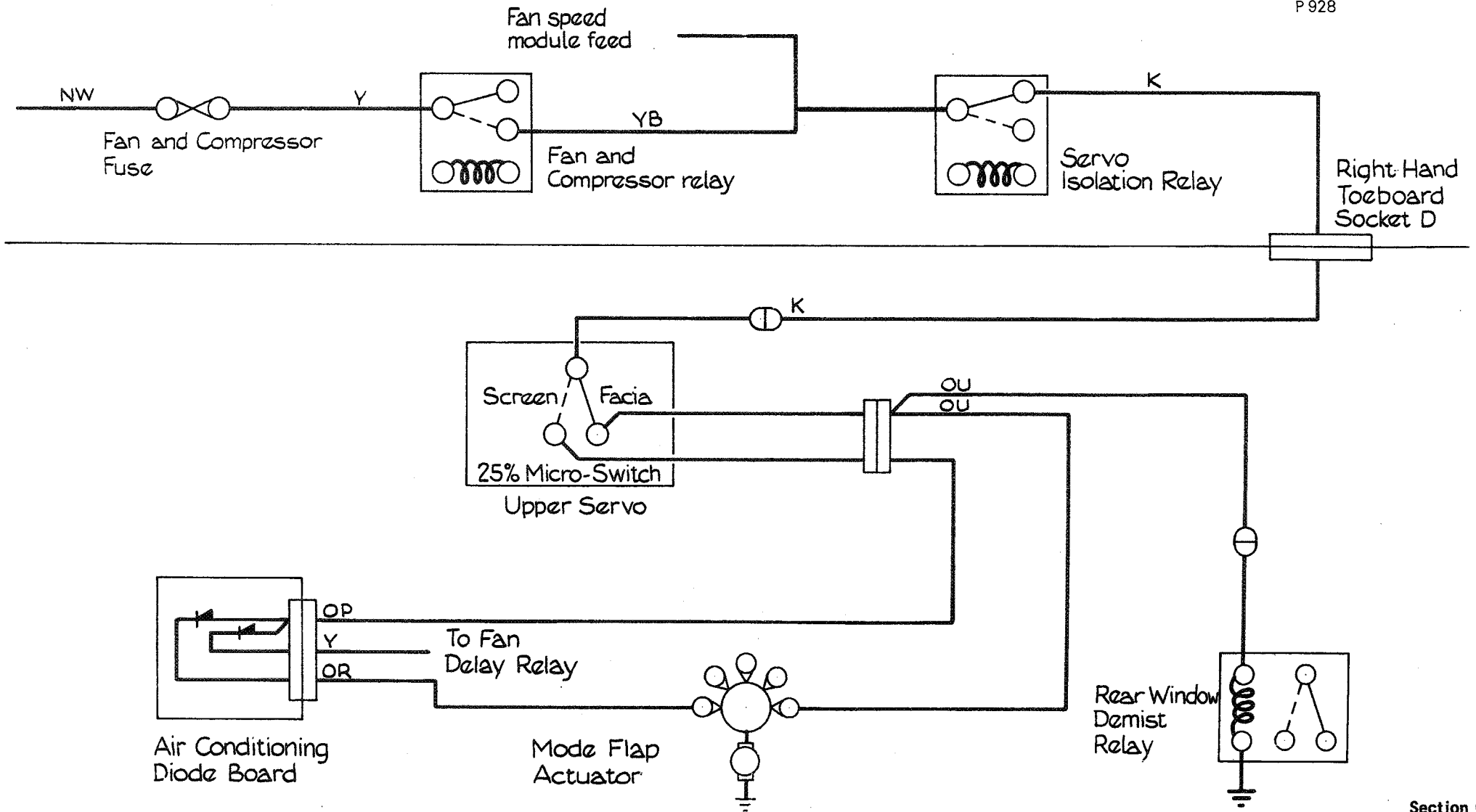

Fig. C67

Voltage Stabiliser Wiring

P 929

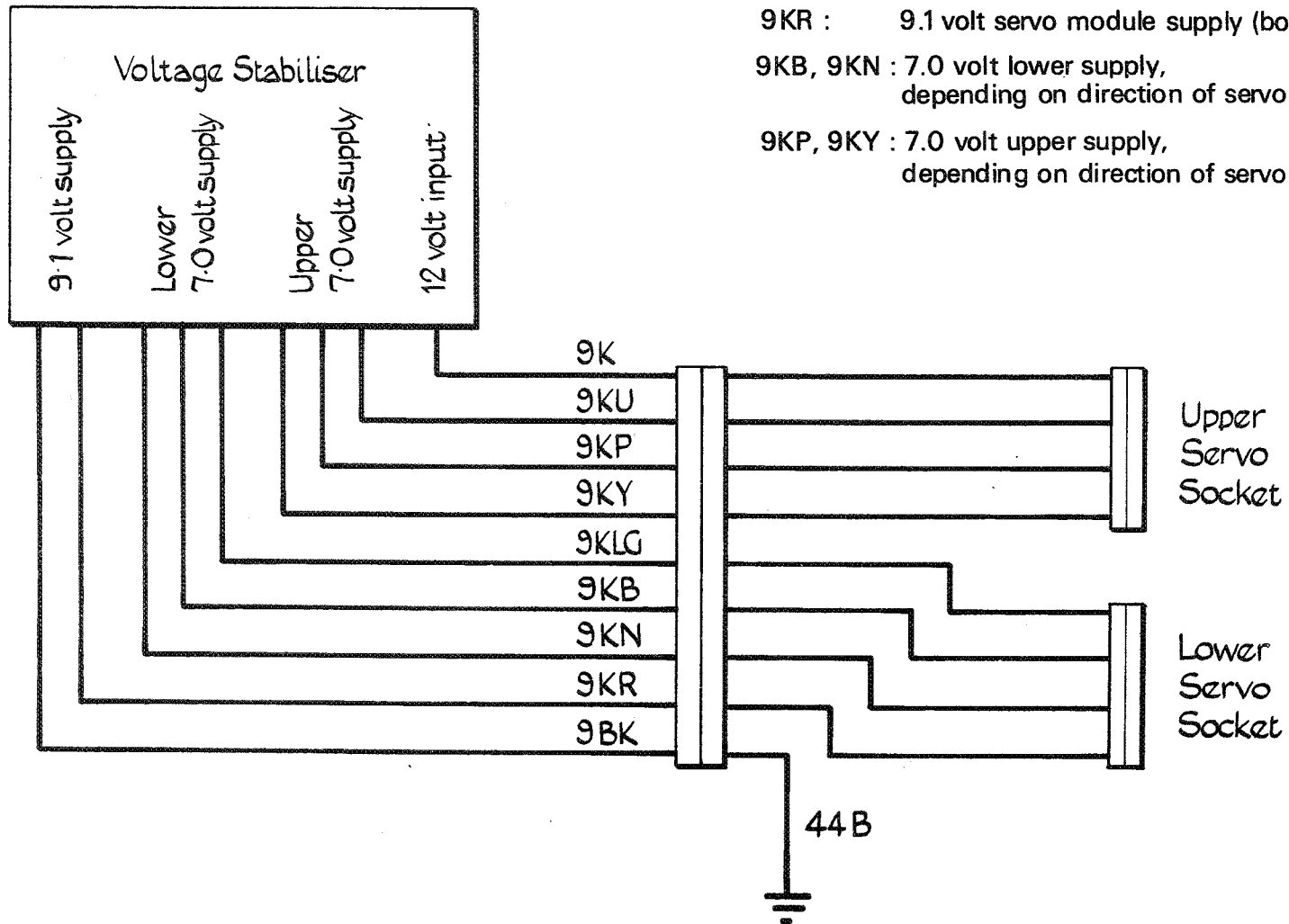

Fig. C68

Fan Motors Circuit

Theoretical/Practical

