

Section J1

Final drive

Introduction

The final drive unit comprises a centre differential gear case which contains the hypoid crown wheel, pinion gear and differential housing gears; two short drive-shafts transmit the drive to the rear wheels. The ball and trunnion joint on each side of the unit is enclosed by a convoluted neoprene seal to prevent oil leakage and the ingress of dirt and water.

The final drive casing is attached to a crossmember which is mounted to the body by rubber mounts.

Torque reaction of the final drive is controlled by a torque arm bolted to the final drive casing and attached to the rear suspension crossmember through rubber mounts.

The complete final drive unit, crossmember, drive-shafts and torque arm can be removed from beneath the car as a complete assembly.

A fully adjusted final drive assembly is available as a service exchange item. This assembly is supplied without half-shaft assemblies but is fitted with side bearing housings.

When fitting half-shafts to a replacement final drive assembly it is essential that the side bearing housings supplied with the assembly are fitted to the half-shafts. The fitting of any other bearing housings will result in an incorrectly adjusted final drive assembly.

Final drive unit – To remove

1. Position the car on a ramp and securely chock the road wheels.
2. Switch on the ignition. Select the 'N' (neutral) position on the gear range selector; switch off the ignition.
3. Remove the drain and level plugs from the final drive and allow the oil to drain into a container. It is advisable to carry out this operation when the oil is warm e.g. immediately after the car has completed a run.

After draining, clean and fit the drain plug complete with new sealing washer.

4. Remove the rear section of the exhaust system as described in Chapter Q – Section Q1.
5. Disconnect the propeller shaft from the differential flange.
6. Disconnect the half-shaft outer universal joints from the hub yokes by removing the eight clamping setscrews; remove the four clamps. To finally detach the joints ease the half-shaft inwards, ensuring that the universal joint needle roller housings are held in position and retained to the universal joint when removed from the yoke.

Note

To carry out Operations 5 and 6 it may be necessary to jack up and rotate a rear road wheel in order to gain access to the necessary nuts and bolts.

7. Support the half-shafts to avoid strain being imposed on the ball and trunnion joint seals by tying the shafts with cord to the final drive crossmember.
8. Support the final drive assembly with a hydraulic jack placed beneath the centre casing.
9. Detach the torque arm from its front mount on the rear suspension sub-frame by removing the two bolts, nuts and special washer (see Fig. J12).
10. Disconnect the earthing lead from the final drive crossmember.
11. Remove the nuts and washers from the centre bolts of the final drive crossmember mounts. It may be necessary to lift the luggage compartment floor carpet and hold the bolt heads whilst removing the nuts.
12. Lower the final drive and crossmember assembly together with the torque arm from the car. Collect the large washers from the top of each crossmember mount.
13. With the assembly suitably supported on a work bench, remove the cord used to support the half-shafts to the crossmember.
14. Detach the crossmember by removing the twelve setscrews from the rear face of the final drive, noting the positions of the eight special interlocking washers. The two centre setscrews on each side of the centre casing rear face may be left in position, to retain the final drive rear cover (see Fig. J11).

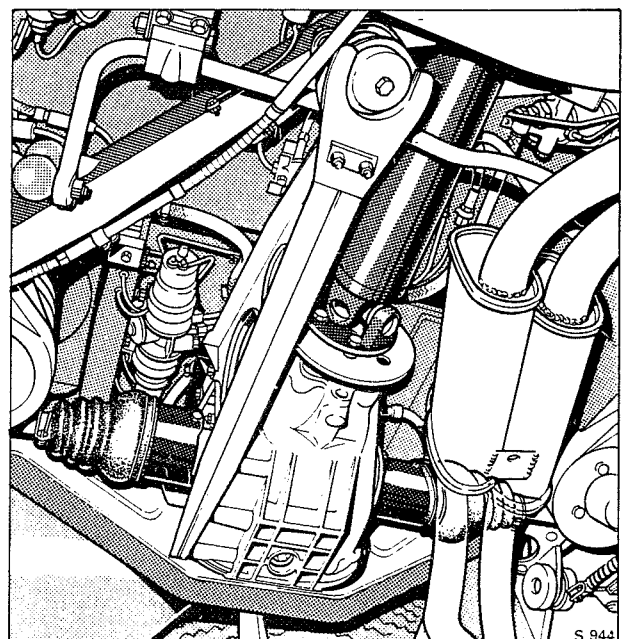

Fig. J1 Final drive in position

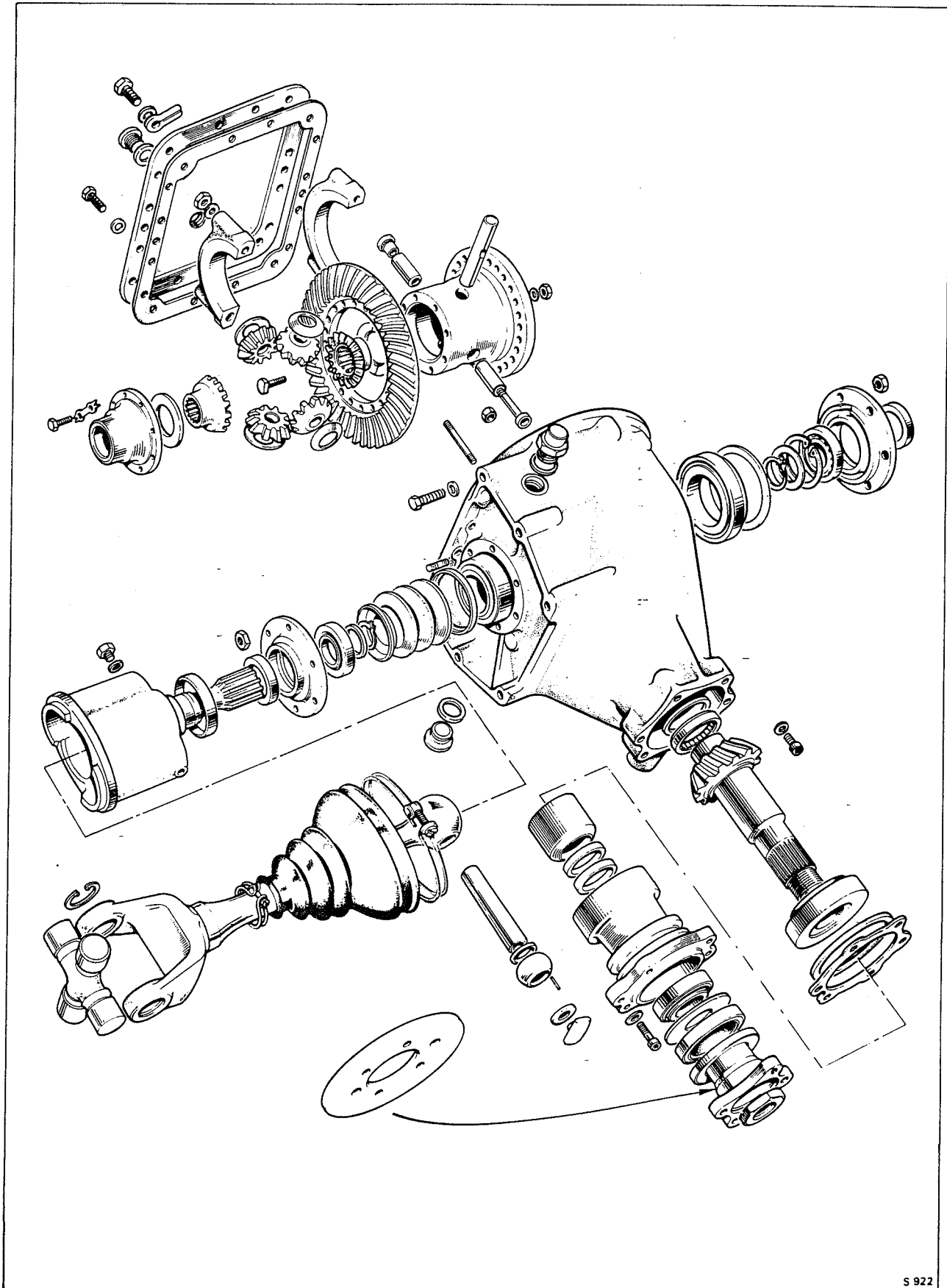

Fig. J2 Final drive

Final drive unit – To dismantle (see Fig. J2)

1. Remove the six retaining nuts from the right-hand half-shaft bearing housing and withdraw the shaft assembly; also the distance piece, three belleville washers and the adjusting washer from behind the housing (see Fig. J15).
2. Remove the six retaining nuts from the left-hand half-shaft bearing housing and withdraw the shaft and the large adjusting washer fitted between the housing and the large crown wheel bearing.
3. Unscrew the four retaining setscrews and remove the differential casing rear cover.
4. Remove the nuts and washers from the bearing caps on each side of the crown wheel and differential assembly (see Fig. J3).

Correlate the caps and casing to ensure that the caps can be refitted into their original positions and then withdraw the caps.

Note

The bearing cap and casing are machined as pairs, therefore, although the caps cannot be fitted to the incorrect side, they must not be fitted in their reversed positions.

5. The crown wheel and differential assembly can now be raised slightly, moved away from the pinion and carefully removed from the casing.

Note

Care should be taken during Operations 4 and 5 to ensure that the two large taper roller bearing tracks do not fall off, as this could cause damage to the rollers or tracks.

6. Remove the four setscrews which secure the pinion housing to the front flange of the casing and insert extractor screws into the two tapped holes in the pinion housing flange.
7. Place the casing in an oven having a temperature of 110°C. (230°F.) for approximately fifteen minutes.
8. Remove the casing from the oven and extract the pinion housing using the two extractor screws; care should be taken to turn the screws evenly and together.
9. To remove the pinion nose bearing, remove the two socket headed screws, retaining nuts and washers and withdraw the bearing.

Crown wheel and differential assembly – To dismantle

When dismantling the crown wheel and differential assembly care should be taken to ensure that all thrust washers and bearing tracks are retained with their appropriate parts to ensure that they are assembled in their original positions.

1. Remove the two bearing outer tracks.
2. Remove the nuts, bolts and washers securing the crown wheel to the differential housing; remove the crown wheel.
3. Unlock and remove the eight setscrews securing the differential housing and cap, remove the cap, splined pinion gear and adjusting washer.
4. Remove the locking nut and long setscrew from the centre of the split trunnion pin; remove the trunnion pins, bevel gears and dished thrust washers.
5. Remove the splined pinion gear and thrust washer from the opposite end of the pinion housing.

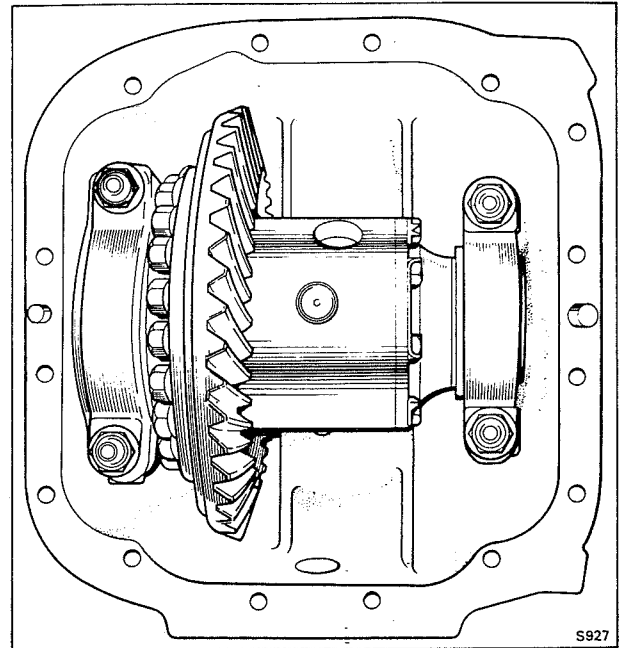

Fig. J3 Differential housing and crown wheel in position

6. Wash all parts thoroughly and dry with compressed air. If it is necessary to renew the large taper roller bearings, press them off the differential housing and end cap.
7. All components should be thoroughly inspected for wear and damage and any defective items renewed.
Thrust washers should be flat and parallel, excluding the four dished thrust washers fitted behind the bevel gears. Ensure that gears and all bearing surfaces are free from damage, pitting, score marks, burrs and excessive wear.

Crown wheel and differential assembly – To assemble

1. If new taper roller bearings are to be fitted they must be pressed squarely onto the diameters situated on the end of the differential housing and end cap. Note that the larger of the two bearings is fitted to the housing and that both bearings should be fully seated against their abutment faces.
2. If the adjusting washer positions are not known or new pieces are being fitted, the procedure for assembling the differential housing described in Operations 3 to 6 inclusive should be carried out.
3. Fit the splined bevel pinion into the end of the differential housing without an adjusting washer behind the head.
4. Fit the trunnion pins, dished washers and bevel gears. The long bolt and nut which connects the split trunnion pins should be torque tightened to between 1,6 kgf.m. and 1,9 kgf.m. (12 lbf.ft. and 14 lbf.ft.).
5. Push the splined pinion gear into mesh with the bevel gears as far as possible and measure the distance from the end of the differential housing to the end face of the pinion gear (see Fig. J4).

Pull the pinion gear back out of mesh as far as possible and again measure the distance from the end of the housing to the end of the gear.

The difference between these two measurements will give the nominal thickness of adjusting washer required behind the gear head.

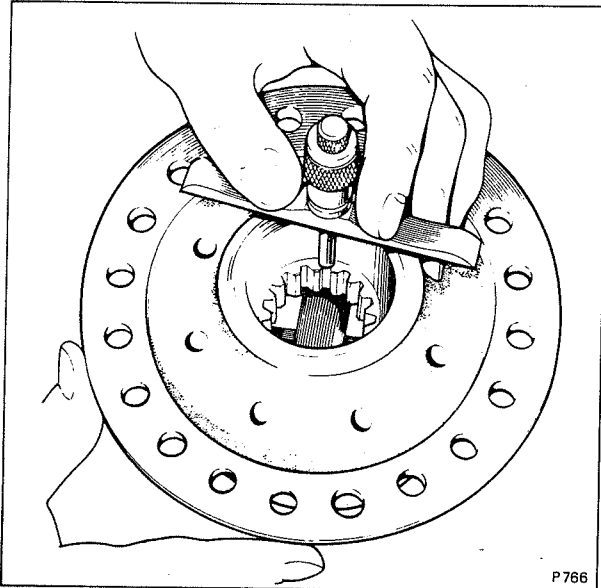

Fig. J4 Splined bevel pinion measurement

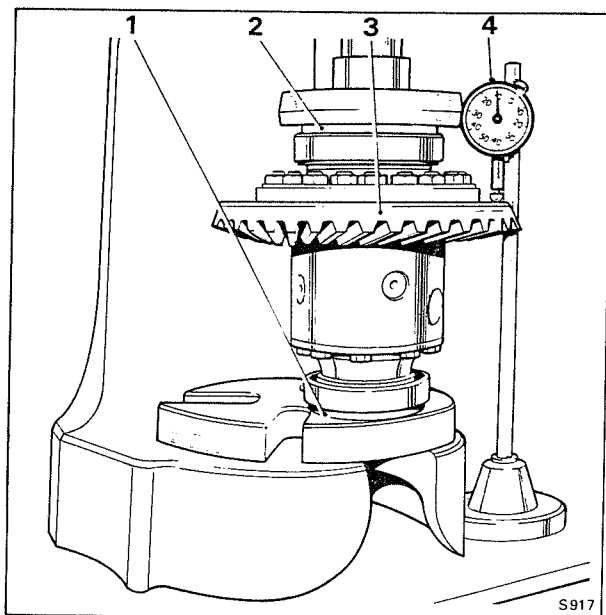

Fig. J5 Checking the crown wheel

- 1 Adjusting washer
- 2 Adjusting washer
- 3 Crown wheel and differential assembly
- 4 Dial test indicator

6. Dismantle the gears, place the correct adjusting washer behind the bevel pinion and assemble the gears.

Adjusting washers are available in a range of between 2,13 mm. and 2,94 mm. (0.084 in. and 0.116 in.) in 0,05 mm. (0.002 in.) increments. The washers must be fitted with the chamfer and oil grooves against the back face of the gear.

7. Rotate the gears to ensure that they are perfectly free but with a maximum backlash of 0,076 mm. (0.003 in.) and no end-float on the bevel gear; adjusting the washer as necessary.

8. Fit the housing end cap and the other splined bevel pinions and repeat Operations 3 to 7 inclusive to determine the adjusting washer required.

Note

When the unit is assembled correctly the gear should turn freely with a maximum of 0,076 mm. (0.003 in.) backlash between the gears and no end-float in the splined bevel pinions.

9. When the differential gears are correctly set, check that the torque tightness of the split trunnion centre bolt is between 1,6 kgf.m and 1,9 kgf.m. (12 lbf.ft. and 14 lbf.ft.) then lock the nut in position.

10. Torque tighten the end cover setscrews in accordance with the figures quoted in Chapter P and lock the tabwashers.

11. Fit the crown wheel to the differential housing and torque tighten the nuts to the figures quoted in Chapter P.

12. Check the crown wheel for axial run-out.

Any convenient method may be used to check this e.g. on a mandrel between the centres. One method which may be used is described in Operations 13 and 14.

13. Place the roller bearing outer tracks in position and stand the assembly on one end. Position the assembly in a press with one adjusting washer fitted to each bearing (see Fig. J5).

14. Apply light pressure and using a dial indicator, check the run-out of the crown wheel; the run-out should not exceed 0,05 mm. (0.002 in.).

If the run-out exceeds this figure vary the crown wheel position relative to the differential housing until the run-out is within the 0,05 mm. (0.002 in.) limit.

Pinion housing – To dismantle

1. Remove and discard the 'O' ring fitted to the pinion housing.

2. Unscrew and remove the nut securing the pinion flange and damper; remove the flange using the special hydraulic ram (RH 8017) and special extractor beam (RH 8470).

3. Remove the pinion oil seal and the oil flinger fitted behind it.

4. Position the housing in a press with the pinion gear downwards. With the housing lower end firmly supported, carefully press the pinion out of the housing.

5. Collect the spacer and adjusting washers from the pinion shank and the taper roller bearing from the housing.

6. If new taper roller bearings are to be fitted, the outer tracks must be removed from the housing using a soft drift and a hammer, taking care to avoid damaging the bearing locating bores.

7. The large taper roller bearing should be removed from beneath the pinion head using a press and the special extraction tool (RH 8016).
8. Wash all parts thoroughly in paraffin and dry with compressed air.
9. Inspect parts for serviceability; any showing damage, pitting or excessive wear, should be renewed.

Pinion housing – To assemble (see Fig. J6)

1. Lightly lubricate all components paying particular attention to the roller bearing faces.
2. If new bearings are to be fitted press the outer tracks into the pinion housing and the large roller bearing onto the pinion, ensuring that the bearings are square and seated on their abutment faces.
3. Enter the pinion into the housing then fit the spacer and two adjusting washers onto the pinion shank.

The two washers determine the pre-load on the pinion bearings.

It is important that the washers are free from defects and are flat and parallel to within 0,012 mm. (0.0005 in.).

If the pinion bearings have not been renewed, the original washers may be used. If new bearings have been fitted, washers whose combined thickness amounts to between 6,85 mm. and 8,89 mm. (0.270 in. and 0.280 in.) should give the best initial setting.

4. Support the pinion and housing. Press the upper bearing onto the pinion shank until it abuts the adjusting washers.
5. Fit the oil flinger and a new oil seal to the housing. Ensure that the front face of the seal is 3,2 mm. (0.125 in.) below the face of the housing and the seal lip is pointing inwards. The outside diameter of the seal should be brushed with 'Wellseal' sealant before fitting.
6. Smear the inner face of the seal with palm oil, fit the transmission damper to the pinion flange. Enter the flange onto the pinion shank taking care not to damage the oil seal or pinion threads.
7. Press the coupling flange onto the pinion shank using assembly tool (RH 8457) and fit the nut.
8. Tighten the nut to a torque figure of between 3,8 kgf.m and 4,46 kgf.m. (275 lbf.ft. and 300 lbf.ft.). Rotate the pinion housing during tightening to check the free movement of the bearings.
9. Rotate the pinion in the housing several times in both directions then check the pre-load.

The pre-load on the pinion bearings when the housing is out of the final drive casing should be between 1,6 kgf.m. and 2,3 kgt.m (12 lbf.in. and 17 lbf.in.). This can be checked using a spring balance pulling on a bolt inserted into one of the holes in the pinion flange.

Note

The holes in the pinion flange are 4,762 cm. (1.875 in.) away from the centre of the pinion and therefore if this method is used the spring balance reading should be between 2,9 kg. and 4,08 kg. (6.4 lb. and 9.0 lb.). Ensure that the line of pull on the spring balance is truly tangential.

The spring balance reading obtained to initially rotate the pinion will be high. It is the lower steady reading when the pinion is rotating which indicates the pre-load.

10. If the pre-load is not correct the pinion must be extracted from the housing and the adjusting washers changed as necessary to obtain the correct reading.

Adjusting washers are available in a range of between 2,66 mm. and 2,79 mm. (0.105 in. and 0.110 in.) in 0,127 mm. (0.005 in.) increments.

Reducing the combined thickness of the washers will increase the pre-load and increasing the thickness will reduce it. Very small changes to the thickness of the washers has a marked effect on the pre-load figure.

Final drive unit – To assemble

To assemble the final drive unit reverse the procedure given for dismantling ensuring that the crown wheel and pinion are in their correct relative positions and that the amount of backlash between the two gears is correct.

All parts must be cleaned thoroughly prior to assembly and all bearings lubricated.

1. Before assembling the final drive unit the stiffening bar (RH 8032) should be fitted to the final drive casing.
2. Partially screw four 3/8 in. U.N.F. studs into the threaded holes in the front of the final drive casing. It is sufficient to fit these by hand as they serve only as location pegs for the pinion housing.
3. If the pinion nose bearing has been removed from the casing, fit the bearing, snap ring and the two socket headed retaining screws, nuts and washers. Torque tighten the screws (see Chapter P) and centre punch the nuts in three places to lock them into position.

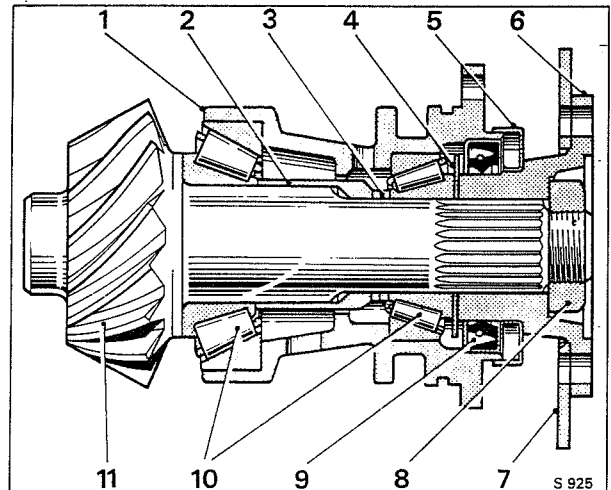

Fig. J6 Pinion assembly

- | | |
|----|----------------------------|
| 1 | Pinion housing |
| 2 | Spacer |
| 3 | Pre-load adjusting washers |
| 4 | Oil flinger |
| 5 | Shield |
| 6 | Pinion flange |
| 7 | Damper |
| 8 | Pinion flange nut |
| 9 | Oil seal |
| 10 | Taper roller bearings |
| 11 | Pinion |

4. Note the dimension stamped on the final drive casing (see Fig. J7) then place the casing in an oven having a temperature of 110°C. (230°F.) for approximately thirty minutes.
5. Carefully measure from the back face of the pinion housing front flange to the face of the pinion gear, adjacent to the nose bearing diameter (see Fig. J8 dimension X).
6. Add this figure to the dimension etched on the rear face of the pinion (dimension Y).

The dimension 'A' stamped on the final drive casing which was noted previously must now be subtracted from the total of dimensions 'X' and 'Y'.

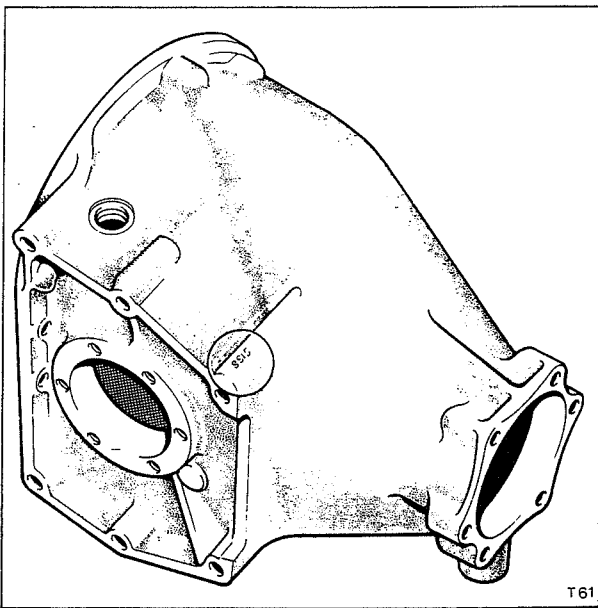

Fig. J7 Stamped dimension on final drive casing

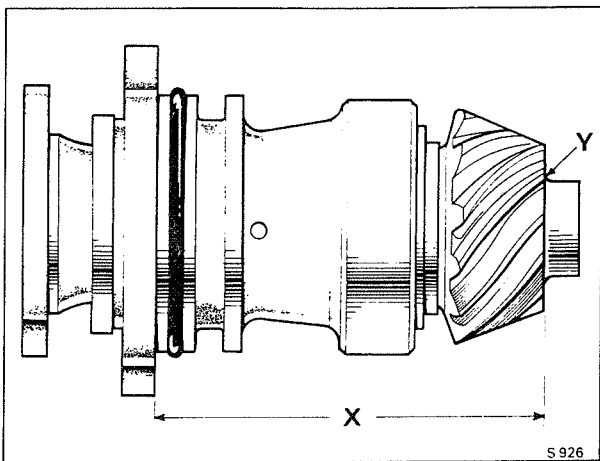

Fig. J8 Pinion housing measurement
 X Dimension between housing and pinion gear
 Y Dimension etched on pinion gear face

The final dimension gives the thickness of the split adjusting washer which must be used between the pinion housing flange and the casing, to place the pinion in the correct position.

$$\text{Thickness of washer} = X + Y - A$$

The above measurements must be taken carefully and accurately.

Split adjusting washers are available in the following sizes 3,048 mm. (0.120 in.), 3,175 mm. (0.125 in.), 3,302 mm. (0.130 in.), 3,479 mm. (0.137 in.) and 3,784 mm. (0.147 in.).

7. Remove the casing from the oven and fit the split adjusting washers over the studs.
8. Fit a new 'O' ring to the pinion housing and insert the housing into the casing as far as possible.

Note

The pinion housing has one off-set hole and can therefore only be fitted in one position. It is advisable to establish this position before entering the housing into the casing.

9. Remove the locating studs; fit the four Allen cap setscrews and tighten them progressively and evenly to a torque figure of 4,0 kgf.m. to 4,4 kgf.m. (29 lbf.ft. to 32 lbf.ft.).
10. Examine the crown wheel and note the backlash figure etched on the back face.
11. Carefully place the crown wheel and the differential assembly in position; fit the bearing caps but do not tighten the nuts.
12. If the two final drive side housings are still connected to the half-shafts, remove the retaining circlips and remove the housings from the shafts.
13. Fit the adjusting washer with the chamfered face outward, three belleville washers with the convex side outward, distance piece and housing on the right-hand side of the final drive casing and progressively tighten the housing securing nuts (see Fig. J15).
14. Fit the two adjusting washers behind the crown wheel bearing and fit the left-hand side housing. Progressively tighten the housing nuts whilst rocking the crown wheel back and forth to ensure that there is backlash between the gears.
15. Mount a dial test indicator on the final drive casing with the indicator pad on the flank of a crown wheel tooth.
16. Zero the indicator and 'rock' the crown wheel back and forth noting the backlash.
17. The backlash should be checked at four positions around the crown wheel and an average reading taken. This figure should be marginally less than the backlash figure etched on the crown wheel.

If it does not conform, the thickness of the washer behind the bearing must be varied to obtain the correct reading.

Washers are available in a range of between 5,664 mm. and 6,604 mm. (0.223 in. and 0.260 in.) in increments of 0,101 mm. (0.004 in.).

18. In order to obtain the required result equal amounts may be ground from each side of the washer, taking care to ensure that, after grinding, the washer is still flat and parallel to within 0,025 mm.(0.001 in.).
19. When the backlash is correct, remove the side housing from the centre casing; slide the housing onto the half-shaft assembly and fit the circlip.

20. Fit the complete assembly to the final drive casing after applying a light coating of SQ 32M jointing compound to the joint faces of the casing and housing.

21. Remove the right-hand housing, distance piece, belleville washers and adjusting washers.

22. Accurately measure the distance from the casing flange to the taper roller bearing outer track (see Fig. J9)

23. Place the housing, distance piece and belleville washers in the checking jig (RH 7861) and tighten the jig end pieces until the belleville washers are flat (see Fig. J10).

24. Using feeler gauges, measure the distance between the housing flange face and the top of the two pins on the gauge. The result added to the nominal pin height marked on the gauge gives the distance from the side housing to the belleville washers.

Subtract this dimension from the dimension previously taken between the casing flange and the taper bearing; the result gives the thickness of the adjusting washer which must be fitted between the belleville washers and the taper bearing, to give the correct pre-load.

Adjustment washers are available in a range of between 5,08 mm. and 6,60 mm. (0.200 in. and 0.260 in.) in increments of 0,254 mm. (0.010 in.). Washers may be lightly ground to obtain the correct dimensions but if this is done, equal amounts must be removed from each side and the washer must be kept flat and parallel.

25. Fit the right-hand side housing to the half-shaft.

26. Fit the correct washer with the chamfered side outwards, the three belleville washers, convex side outwards and the distance piece. Fit the housing and half-shaft assembly after applying a light coating of SQ 32M jointing compound to the flange faces.

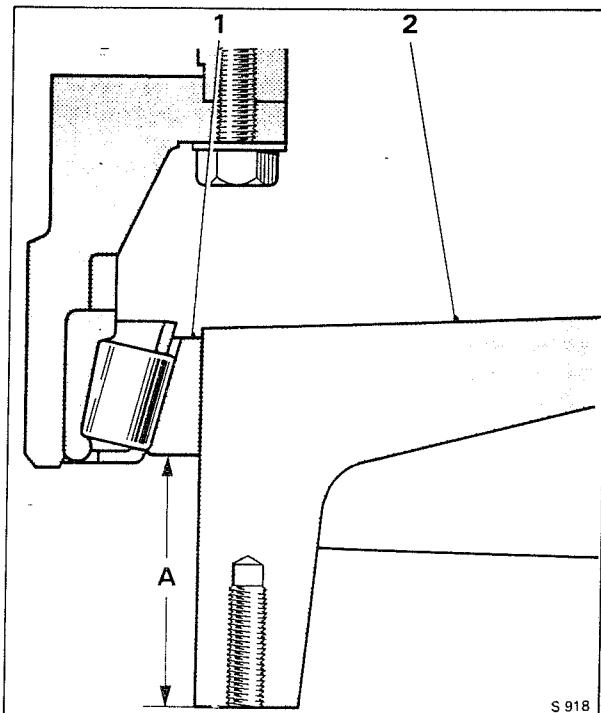

Fig. J9 Casing flange to bearing measurement

- A Measurement — flange to bearing
- 1 Bearing outer track
- 2 Final drive casing flange

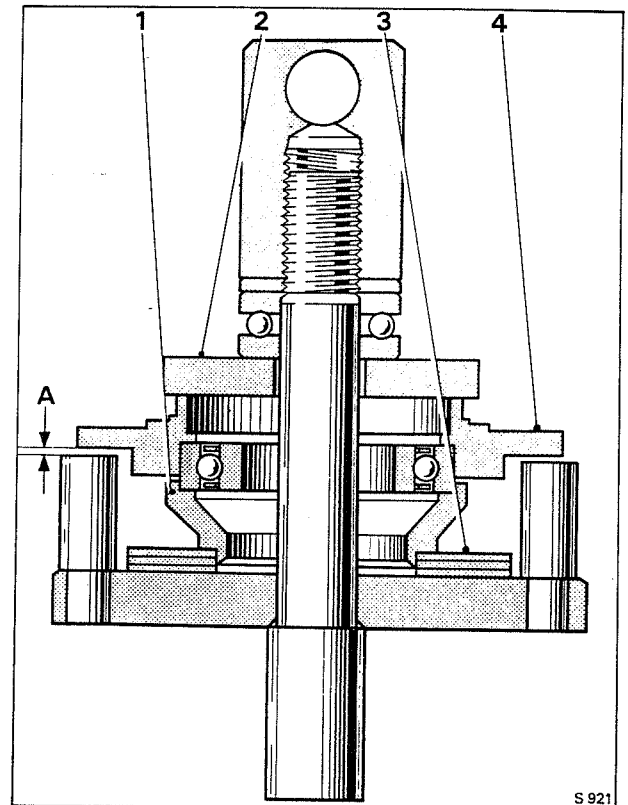

Fig. J10 Belleville washer setting

- A Measured gap
- 1 Distance piece
- 2 Tool (RH 7861)
- 3 Belleville washers
- 4 Final drive side housing

27. Tighten the housing securing nuts progressively and evenly and finally torque tighten them to between 1,1 kgf.m. and 1,4 kgf.m. (8 lbf.ft. and 10 lbf.ft.).

28. Torque tighten the nuts securing the two large bearing caps in accordance to the figures quoted in Chapter P.

29. Release the six side cover retaining nuts approximately 3,17 mm. (0.125 in.) to release the casing load.

30. Remove the stiffening bar (RH 8032); fit the gasket and end cover. Fit and tighten the four setscrews adjacent to the two dowels.

31. Progressively tighten the six side cover retaining nuts previously released in Operation 29.

32. Rotate the pinion coupling flange to ensure that there are no tight spots or roughness of operation.

Final drive unit — To fit

To fit the final drive unit reverse the procedure given for removal noting the following points.

1. The rear crossmember should be fitted with the eight interlocking washers fitted correctly on the eight corner setscrews (see Fig. J11).
2. Support the drive-shafts by securing them to the final drive crossmember with cords to retain the detroit joints in position.

3. When fitting the universal joints to the yokes ensure that the needle roller bearing caps are located correctly into the hub yokes before fitting the retaining caps and setscrews.
4. The propeller shaft and pinion flange faces must be clean and free from damage before securing together.
5. When fitting the exhaust system reference should be made to Chapter Q Exhaust systems.
6. Torque tighten all bolts and nuts in accordance with the figures quoted in Chapter P.
7. After fitting the final drive unit ensure that the drain plug is tightened, remove the filler plug from the rear cover and fill the axle with one of the recommended lubricants (see Chapter D), up to the level of the plug (approximately 2,55 litres (4½ Imperial pints, 5½ U.S. pints).
8. Fit the filler plug together with a new joint washer.

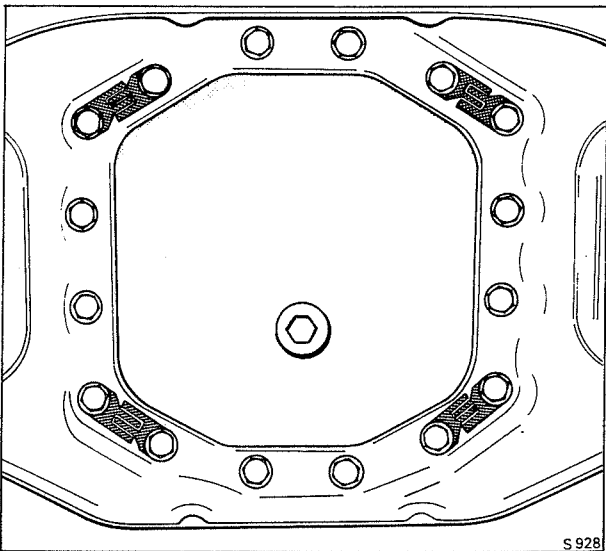

Fig. J11 Locking washers – final drive end cover

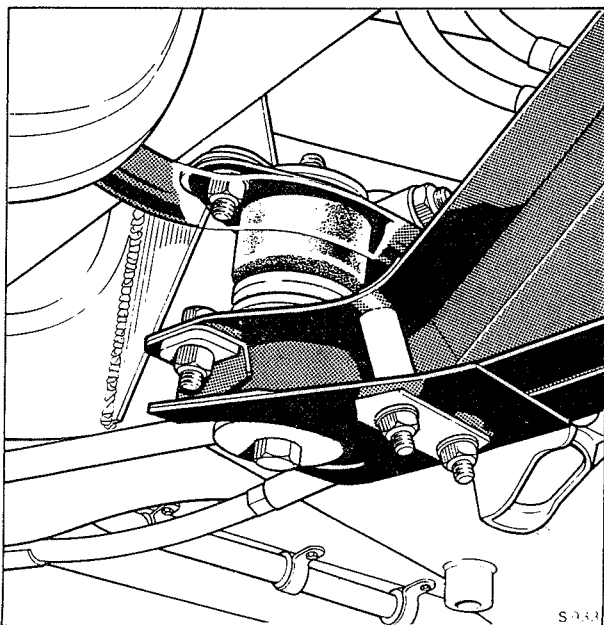

Fig. J12 Torque arm front mount

Pinion flange oil seal – To renew

The pinion flange oil seal may be renewed with the final drive unit in position.

1. Place the car on a ramp and securely chock the road wheels.
2. Remove the bolts and nuts securing the propeller shaft to the pinion flange.
3. Remove the bolts and nuts securing the propeller shaft front flange to the transmission output flange. Ease the propeller shaft forward and downward sufficiently for the rear flange to be clear of the final drive pinion flange. It is not necessary to remove the propeller shaft completely.
4. Scribe correlation marks across the pinion face, coupling flange and transmission damper. Remove the pinion nut.
5. Using the hydraulic ram (RH 8017) and special extractor (RH 8470) remove the pinion flange.
6. Using a lever or simple extractor remove the oil seal from the pinion housing.
7. Fit a new oil seal, ensuring that it is fitted squarely, with the lip pointing inward and that the front face of the seal is 3,2 mm. (0.125 in.) below the front face of the housing.
8. Clean and fit the pinion flange and damper ensuring that the correlation lines are in line. Failure to do this will result in pinion imbalance. Fit and torque tighten the nut to the figure quoted in Chapter P.
9. Connect both ends of the propeller shaft and torque tighten the nuts to the figure quoted in Chapter P.

Torque arm – To remove

Removal of the torque arm can be carried out without disturbing the final drive unit.

1. Place the car on a ramp and securely chock the road wheels.
2. Support the final drive unit by placing a jack under the centre casing.
3. Remove the two nuts, bolts and heavy washers securing the torque arm to the mount on the rear suspension crossmember.
4. Remove the six setscrews securing the torque arm to the final drive casing; remove the torque arm.
5. Inspect the torque arm mount on the rear suspension crossmember for any signs of failure or softening of the rubber and renew if necessary.
6. Clean and visually inspect the torque arm for serviceability.

Torque arm – To fit

Fit the torque arm by reversing the procedure given for removal noting the following points.

1. All nuts and bolts should be torque tightened in accordance with the figures quoted in Chapter P.
2. It is essential that the heavy duty washers and strengthening pieces are fitted to the front mount (see Fig. J12).