

Section K4

Fuel lines and Ancillary equipment

This section contains details of the components within the fuel system that are fitted between the fuel tank and carburettors (with the exception of the fuel pumps).

If it is necessary to open any of the fuel lines it is most important to ensure that the workshop safety precautions listed in Chapter A (i.e. no smoking, fire extinguishers, battery disconnected etc.) are strictly adhered to.

The components included in this section are listed below and their positions relative to the fuel system illustrated in Figure K1.

Fuel filter (main)
Check valve
Fuel cooler
Fuel recirculation valve
One-way valve
Fuel lines

Fuel filter (main)
 Access to the filter is from beneath the car. The

filter is mounted either below the forward edge of the luggage compartment floor or to the rear face of the centre crossmember, dependent upon the car's intended domicile (see Figs. K36 and K37).

At the service intervals specified the fuel filter element should be discarded and a new one fitted.

Fuel filter - Element replacement

1. Carry out the necessary workshop safety precautions.
2. Slacken the worm drive clips on each side of the filter top cover and withdraw the inlet and outlet pipes. Blank off the pipes to prevent loss of fuel or ingress of dirt.
3. Remove the two nuts, bolts and washers securing the filter to the mounting bracket and lower the filter from the car.
4. Using a thick bladed screwdriver unscrew the three screws securing the top cover, collect the screws and withdraw the filter bowl.
5. Drain the fuel from the filter bowl.

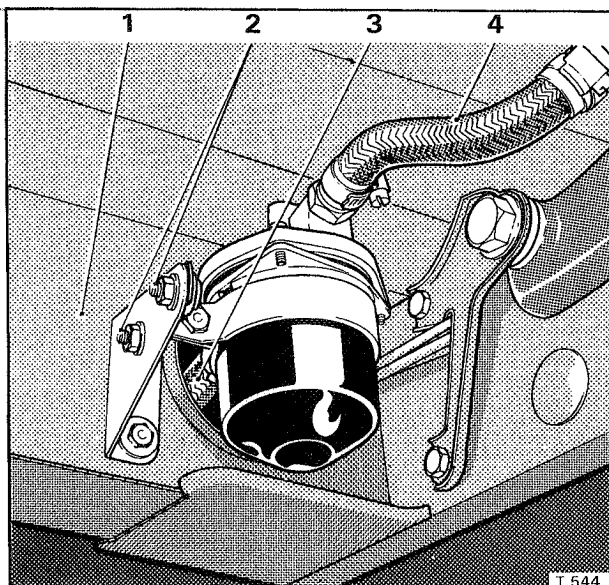

Fig. K36 Rear fuel filter (main) -
Cars destined for countries other than
Canada, Japan and the U.S.A.

- 1 Centre crossmember
- 2 Filter securing bolts
- 3 Outlet pipe
- 4 Inlet pipe

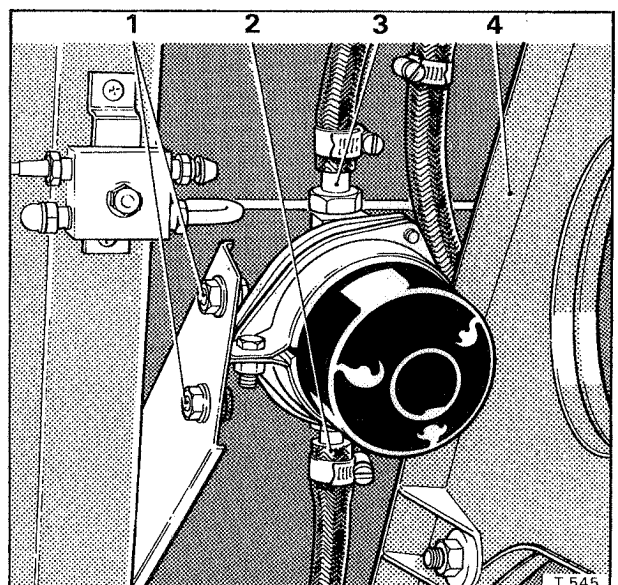

Fig. K37 Rear fuel filter (main) -
Cars destined for Canada, Japan and
the U.S.A.

- 1 Filter securing bolts
- 2 Outlet pipe
- 3 Inlet pipe
- 4 Torque arm

K4 - 2

6. Withdraw the filter element. Resistance may be felt due to the tight fit of the element on the rubber 'O' ring located on the centre (outlet) spigot.
7. Thoroughly clean the filter bowl.
8. Fit a new element by reversing the procedure given for removal. Ensure that new rubber sealing rings are fitted.

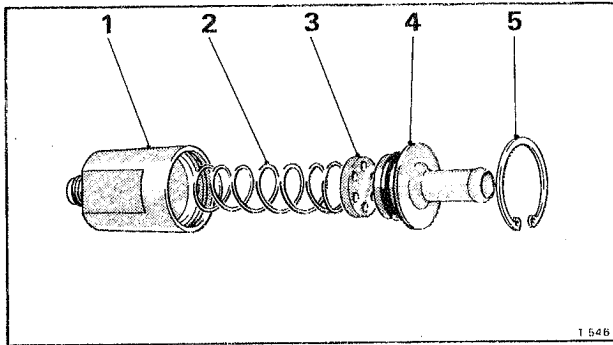

Fig. K38 Check valve

- 1 Valve body
- 2 Spring
- 3 Seating disc
- 4 Adapter
- 5 Circlip

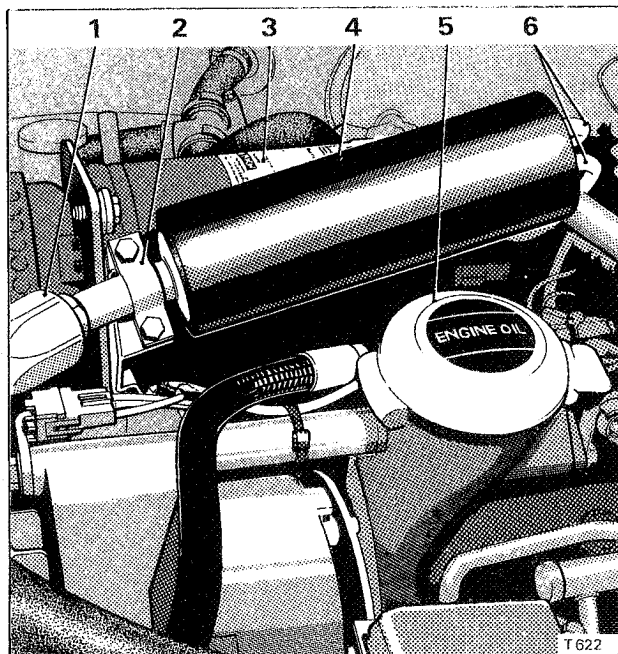

Fig. K39 Fuel cooler

- 1 Flexible refrigeration pipe
- 2 Front securing clip
- 3 Refrigeration compressor
- 4 Fuel cooler
- 5 Engine oil filler cap
- 6 Inlet and Outlet fuel pipes

Check valve (see Fig. K38)

The check valve (if fitted) is situated in the fuel feed line forward of the rear crossmember.

Fuel under pressure from the pump, moves the small valve from its seating and passes through the holes in the valve disc. When the pump is not operating, the fuel pressure drops and a spring returns the valve disc to the adapter face, thus sealing the feed line.

Check valve - To remove and fit

1. Carry out the necessary workshop safety precautions.
2. Slacken the worm drive clip and remove the inlet pipe. Blank off the pipe to prevent loss of fuel or ingress of dirt.
3. Holding the valve body with a $1\frac{1}{4}$ in. A/F open ended spanner, slacken the outlet fuel pipe nut using a $\frac{1}{2}$ in. A/F spanner, remove the check valve and blank off the pipe.
4. Fit the check valve by reversing the removal procedure.

Check valve - To dismantle

1. Remove the check valve from the car.
2. Remove the circlip from the inlet end.
3. Detach the adapter from the valve body. Take care as the adapter is withdrawn as this will release the slight pressure on the internal spring.
4. Withdraw the seating disc and spring.

Check valve - To assemble

Assemble the valve by reversing the procedure given for dismantling, noting the following.

1. Ensure a new 'O' ring is fitted to the adapter.

Check valve - To clean

When the valve has been dismantled it may be cleaned using either clean fuel or paraffin.

Fuel cooler (see Fig. K39)

The fuel cooler operates when the air conditioning system is switched on. However, cars produced to the 'high altitude' specification for North America have a by-pass loop around the air conditioning fascia switch, this allows the cooler to operate at all times, subject to certain temperature and air conditioning system limitations.

Operation

The fuel cooler is basically a chamber around which cold refrigerant is circulated; into this chamber the fuel pipe is looped. Therefore, the temperature of the fuel is reduced before it reaches the carburetters.

Fuel cooler - To remove

1. Depressurize the refrigeration system (see Chapter C).
2. Unscrew both inlet and outlet fuel pipe unions using $\frac{1}{4}$ in. Whit. and $\frac{1}{2}$ in. A/F spanners.

3. Disconnect the flexible refrigeration pipe from the fuel cooler outlet using a $\frac{7}{8}$ in. A/F spanner.
4. Using a $\frac{7}{8}$ in. A/F spanner, unscrew the bolt fitted through the securing plate on the rear of the refrigeration compressor; withdraw the bolt and plate.
5. Using a $\frac{7}{8}$ in. A/F spanner, unscrew the nuts securing the cooler pipe clip to the front of the compressor. Collect the nuts, washers, clip and bolts. Withdraw the fuel cooler and collect the 'O' ring from the compressor connection.

Fuel cooler - To fit

Fit the fuel cooler by reversing the procedure given for removal, noting the following points.

1. Ensure a new 'O' ring is fitted to the refrigeration compressor pipe connection.
2. Charge the refrigeration system as described in Chapter C.

Fuel recirculation valve (restrictor) (see Fig. K40)

On cars fitted with a fuel recirculation system a fuel recirculation valve is fitted in 'A' bank carburettor outlet fuel pipe. The valve restricts the flow of fuel returning to the tank by metering it through a small hole of 1,88 mm. (0.074 in.) diameter; this maintains the required pressure in the fuel feed side of the system.

Fuel recirculation valve - To remove and fit

1. Hold the recirculation valve using a $\frac{3}{4}$ in. A/F open ended spanner and slacken the outlet fuel pipe nut with a $\frac{5}{8}$ in. A/F spanner. Unscrew the nut and withdraw the pipe.
2. Slacken the recirculation valve and withdraw it from 'A' bank carburettor filter housing.
3. To fit the recirculation valve reverse the removal procedure.

Non-return valve (see Fig. K41)

The operation of the Pierburg one-way valve is described in Section K1 and is only fitted to cars with a fuel recirculation system. It is manufactured from fuel resistant nylon. The valve is a non-serviceable unit and if its operation is suspect a new assembly should be fitted. The fuel flow is indicated by the directional arrow embossed on the valve body.

Access to the valve is from beneath the car and its location is in the fuel return line just prior to the fuel tank.

Non-return valve - To remove

1. Carry out the necessary workshop safety precautions.
2. Clamp the rubber fuel pipe before and after the valve.
3. Slacken the worm drive clips either side of the valve and withdraw the pipes.
4. Blank off the open pipe connections if the new valve is not fitted immediately.

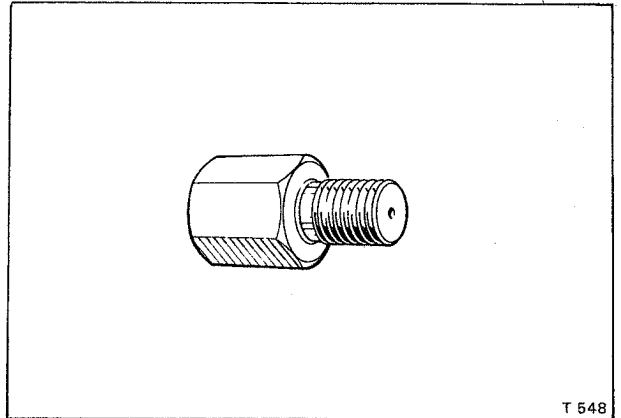

Fig. K40 Fuel recirculation valve (restrictor)

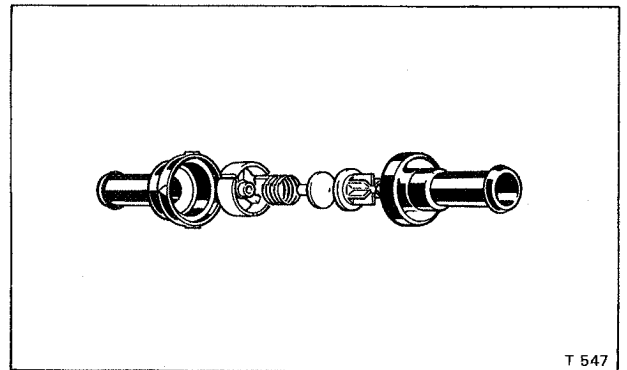

Fig. K41 Non return valve

Non-return valve - To fit

To fit the non-return valve reverse the procedure given for removal, noting the following point.

1. Ensure that the valve is fitted the correct way around; fuel flow directional arrows are situated on the valve body.

Fuel lines

The fuel lines comprise metal bundy tubing and reinforced petrol resistant rubber.

On cars with a fuel recirculation system the feed line is 7,94 mm. ($\frac{5}{16}$ in.) outside diameter. The outside diameter of the return line is 9,53 mm. ($\frac{3}{8}$ in.).

On all other fuel systems the outside diameter of the fuel lines is 9,53 mm. ($\frac{3}{8}$ in.).

Metal piping is used where possible and is attached to the body and inner longeron etc., by metal clips (with rubber inserts) and self-tapping screws.

Rubber piping is used where a joint, component, or flexibility is required.

The various systems are illustrated in Figure K1.