

Contents

Chapter

- A General information
- B Specifications and special tool kits
- C Maintenance requirements
- D Lubrication
- E Engine
- F Clutch
- G Gearbox
- J Brakes
- K Rear axle and drive-shafts
- L Front axle (rigid)
- N Steering
- O Springs and shock dampers
- Q Electrical and ignition
- R Radiator and cooling system
- V Hubs

GENERAL INFORMATION

SERVICE INSTRUCTION LEAFLET

ISSUED BY

BENTLEY MOTORS (1931) LTD.



BM.1.

Subject: Recommissioning of Cars after Period of Storage
3½ and 4¼ Litre Bentley.

Date of Issue 24th Sept. 45.

SB.5/M.

Conditions have arisen now where many cars are being brought into use again after a period of storage, and recognising the fact that the demand for service or assistance will, during the present phase, far exceed that which Bentley Motors Ltd. are able to offer, this leaflet has been compiled to afford guidance in preparing and recommissioning cars for the road, and to ensure that attention is directed to the essential points which affect the reliability and roadworthiness of the car. Obviously, a number of additional matters may require attention depending on the mechanical condition of the car before storage, and the work described herein represents the minimum attention necessary to ensure satisfactory operation.

IMPORTANT

THE CONTENTS
OF THIS
DOCUMENT ARE
STRICTLY
CONFIDENTIAL
AND ARE NOT
TO BE
TRANSMITTED
TO ANY
UNAUTHORIZED
PERSON.

It is assumed that at the time of storage, the car was treated in accordance with the recommended procedure issued by Bentley Motors Ltd., but it is recognised that the actual conditions of storage in regard to heating and ventilation etc., and the amount of attention subsequently received by the car during storage will have varied considerably with individual cars. Hence it may be useful first to indicate briefly the disabilities which may result from unsuitable conditions of storage.

(a) Cylinder Bores.

Inadequate initial protection or failure to turn the engine at intervals during storage will result in corrosion in varying degrees. A small amount of corrosion, provided the engine can be turned fairly easily by hand, is not usually serious and will probably wear off very quickly. On the other hand, if the corrosion has been allowed to proceed to the extent that the engine can be turned only with great effort, the condition is serious and a rebore is usually necessary.

(b) Carburetters and Petrol System.

Without doubt, the most likely cause of trouble and unreliability is the presence of a gummy residue resulting from evaporation of any petrol which may have been left in the system. This sets solid and prevents the working of fuel valves or other mechanism. Even if the engine has been made to run satisfactorily, there is a danger that portions of the deposit will subsequently become dislodged and cause stoppage of the car through choking of the petrol passages; therefore, very careful attention must be paid to cleaning out the entire petrol system. Failure to do so may lead to trouble later. A further difficulty arises due to the presence of water, which may have been left in with the petrol, and this causes corrosion and perforation of the petrol tank.

(c) Gearbox and Axle Gears.

If the transmission has not been turned over at intervals during storage, it is possible that those portions of the gears or ball bearings which are exposed above the oil level will have suffered some

- continued -

Continued :-

corrosion due to condensation of moisture on the polished and case-hardened steel, which is more susceptible to corrosion than unhardened materials. The extent of any such corrosion is very indeterminate and, in the event of any appreciable corrosion having taken place, it is questionable whether any corrective treatment short of dismantling the unit and replacing the parts concerned is of any value. It is probable, however, that in many cases the effects of slight corrosion will wear off, and having regard to the shortage of spares at the present time and in the immediate future, it is not recommended that any action should be taken to anticipate trouble from this source. Therefore, no instructions are included in this leaflet in respect of examination of gearbox or axle gears. If the gears or ball bearings have suffered to the extent of requiring replacement, there will be ample warning by way of noise when the car is put into commission.

(d) Clutches.

Failure to have jacked out the clutch before storage, may have resulted in the fabrics adhering to the pressure plates, and it may be found impossible to disengage the clutch. This condition, if severe may render necessary the complete dismantling of the clutch, but before this action is taken, certain procedure suggested later in this leaflet should be observed.

With the foregoing points in mind, it is probable that most cars will respond satisfactorily to the following recommended procedure and will give a reliable period of service before further attention becomes necessary.

1. Tyres.

Before taking the car off the blocks the tyres should be inflated to the correct pressures. Recommended pressures are :-

5.50 x 18 Tyres front	-	30 lb/sq.in.
rear	-	30 lb/sq.in.
6.50 x 17 Tyres front	-	23 lb/sq.in.
rear	-	26 lb/sq.in.

These pressures may differ from those quoted in the Instruction Book, but they have been found to give better results.

2. Battery.

Unless the battery has been correctly stored, and received a refreshing charge, at least every two months, it will be useless and a replacement must be obtained. If it has received the proper treatment during storage a thorough charge should be all that is necessary. The battery clamps should be cleaned with a wire brush and smeared with vaseline.

- 3 -

3. Cylinder Bores.

Where any doubt exists as to the condition of the cylinder bores through lack of attention during storage, remove the sparking plugs and into each cylinder inject two eggcupfuls of a mixture comprising 5 parts engine oil and 1 part colloidal graphite. This mixture should be allowed to stand in the bores several hours, or overnight, after turning the engine by hand to distribute the mixture.

4. Valve Mechanism.

Remove rocker cover and inspect valve mechanism for sweating and rust marks. Thoroughly clean mechanism and pour a liberal quantity of fresh oil over all the parts. Remove tappet covers and see that tappets are well lubricated by oil running down push rods.

No further work on the internal parts of the engine is necessary at this stage.

5. Petrol System.

- (a) Disconnect petrol pipes at float chambers and unscrew union from each float chamber cover, A. Fig. 1. Take out the small filter gauze, B. clean and replace.
- (b) Remove float chamber covers, lift out the floats and carefully clean out the bottom of the float chambers. Note whether there is any sign of gummy deposit. If so, pay particular attention to the remainder of the petrol system.
- (c) Remove the air valve cylinder (dashpot) C., from each carburettor and lift out the piston, D., taking great care not to bend or damage the needle valve, E., attached to the bottom of the piston. Carefully clean the piston with paraffin, or, if the piston or its guide has suffered corrosion during storage, metal polish may be used to remove stains.

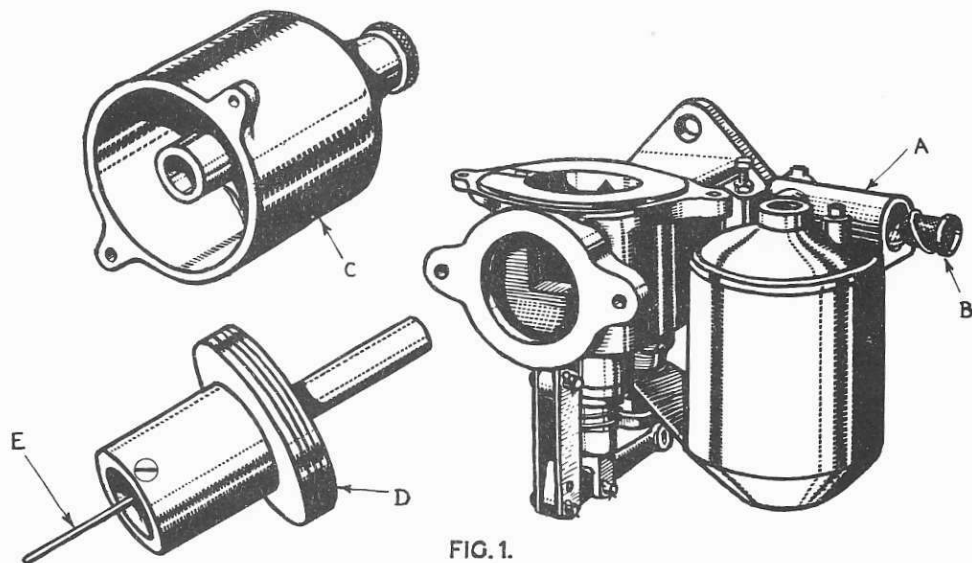
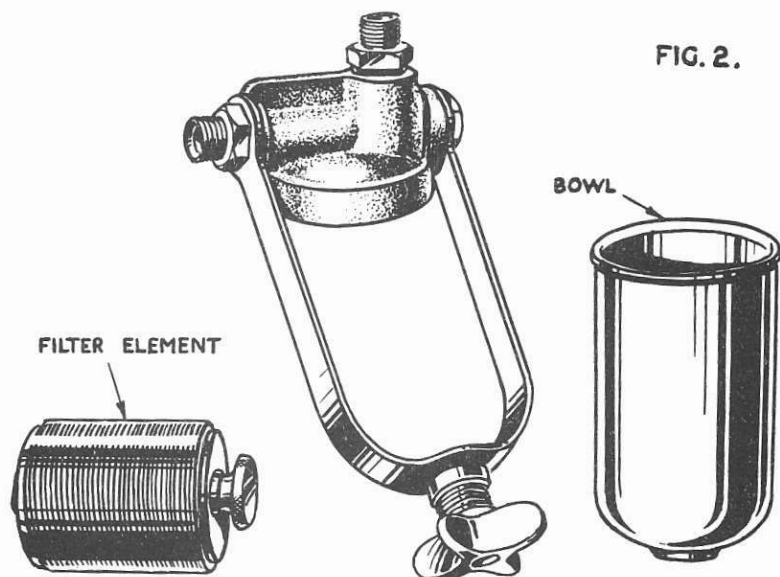

FIG. 1.

Continued :-

- (d) Remove petrol filter elements, and thoroughly clean by washing in petrol (see later note if gummed up). In the case of the $3\frac{1}{2}$ Litre Bentley, the filter is on the dashboard, and is of the type shown in Fig.2. In the case of the $4\frac{1}{4}$ Litre Bentley, dual filters of this type will be found on the rear cross member



- (e) Remove the drain plug from the petrol tank, and inspect for signs of gum deposit. Replace the plug, and make sure it is tight. In the unhappy event of petrol having been left in the tank, with the result that the system is gummed up, special care must be taken to clean out the system. Suitable solvents are :-

Methanol (Methyl Alcohol)

or

Cellulose thinners,

or

Cresylic Acid (Cresol)

Any of the above are effective in dissolving gum where this is present in accessible places, but the petrol tank will take longer and agitation is necessary to bring fresh solvent into contact with the gum. If the tank is badly gummed up, it will probably be necessary to dismantle it from the car, in which case hot caustic soda may be used more effectively than the solvents mentioned above. The tank must be thoroughly washed out afterwards to remove all traces of caustic soda and corrosion deposit. Examine carefully for signs of perforation caused by corrosion.

- (f) Switch on ignition and the petrol pumps should start to purr. If they do not, make sure current is getting to pumps by checking with 12 volt bulb connected between the brass bush inside the pump end covers (removed) and earth. The bulb should light; if not, examine small fuse F. in each cover (Fig.3).

- 5 -

Continued :-

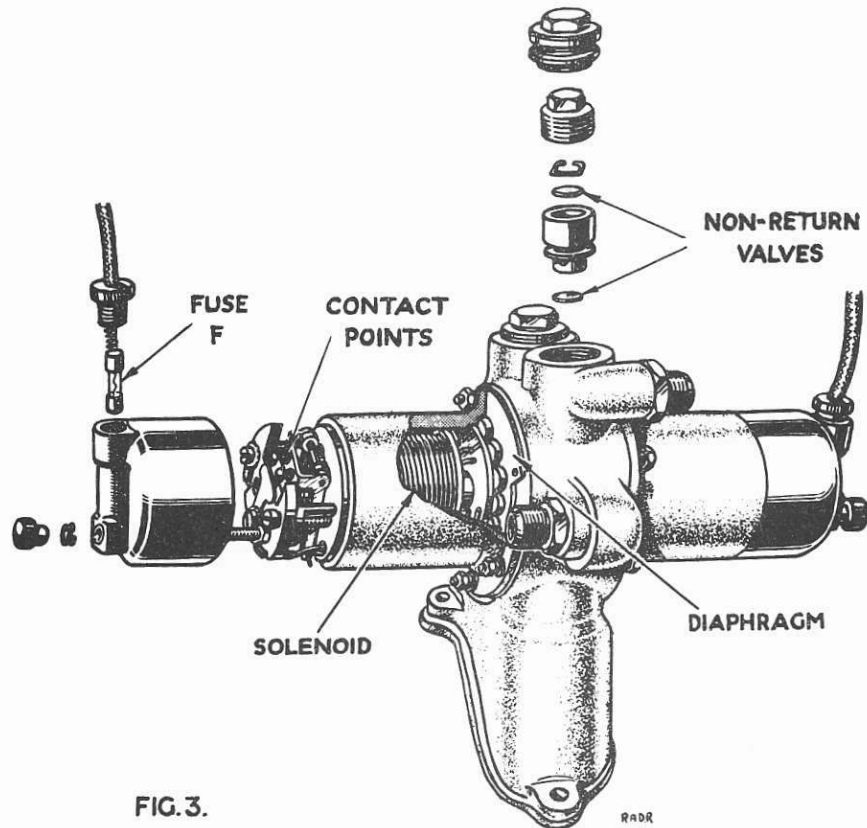

FIG.3.

Should these be correct, then examine No.3 fuse in main fuse box on dashboard. Having ascertained that current is getting to the pumps, and they are still not working, then they are stuck up. Fit the covers on the pump upside down so as to leave the contact points exposed. With the point of a pencil (ignition still switched on) keep gently opening the points. It may take a little time to get the pumps to work again, but if there is no response it will be advisable to fit a pair of reconditioned pumps. Alternatively, new diaphragms may be fitted, but we do not advise this in the absence of expert knowledge.

6. Electrical Equipment.

(a) Dynamo.

Cleanliness of the commutator and freedom of the brushes in their holders should be checked on this unit. Remove the end cover, A. Fig.4 by releasing the pawl, Al., and rotating the cover a third of a turn away from the engine. This will expose the commutator, B. and the brushes, C. Remove the brushes from their holders after lifting the spring clips, D. Brushes, holders and commutator should then be cleaned with a petrol soaked rag and replaced.

On the 4½ Litre model the cover is removed by unscrewing the knurled screws.

Continued :-

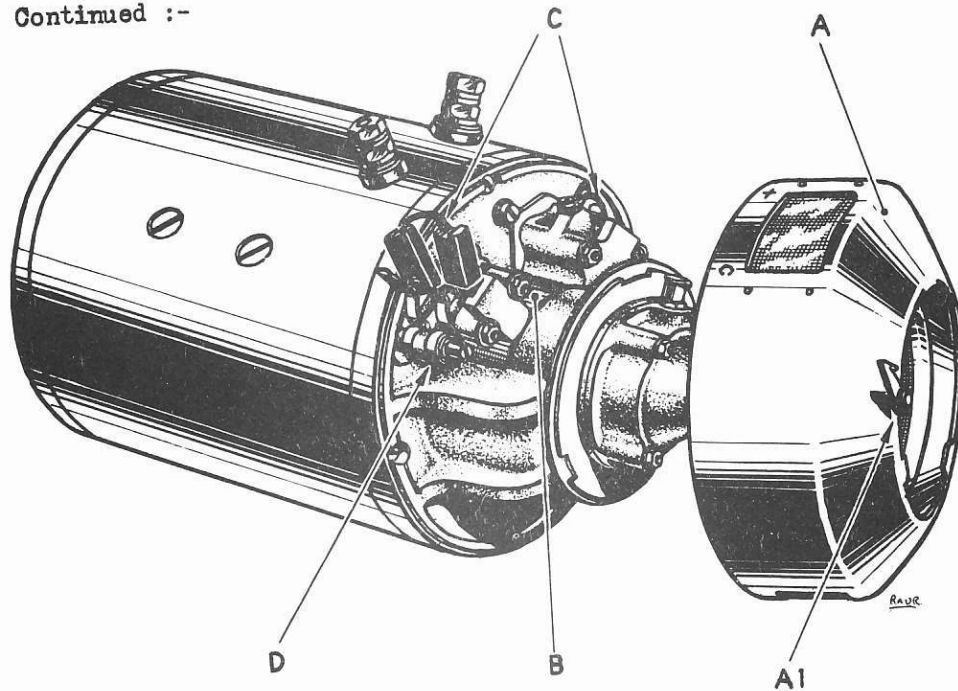

FIG. 4

(d) Distributor.

Remove the high tension distributor cover, K. Fig. 5 and clean contact breaker points with a carborundum strip. Reset the gap to .015" - .018". Adjustment is effected by releasing the locknut, L., and turning the contact screw, M.

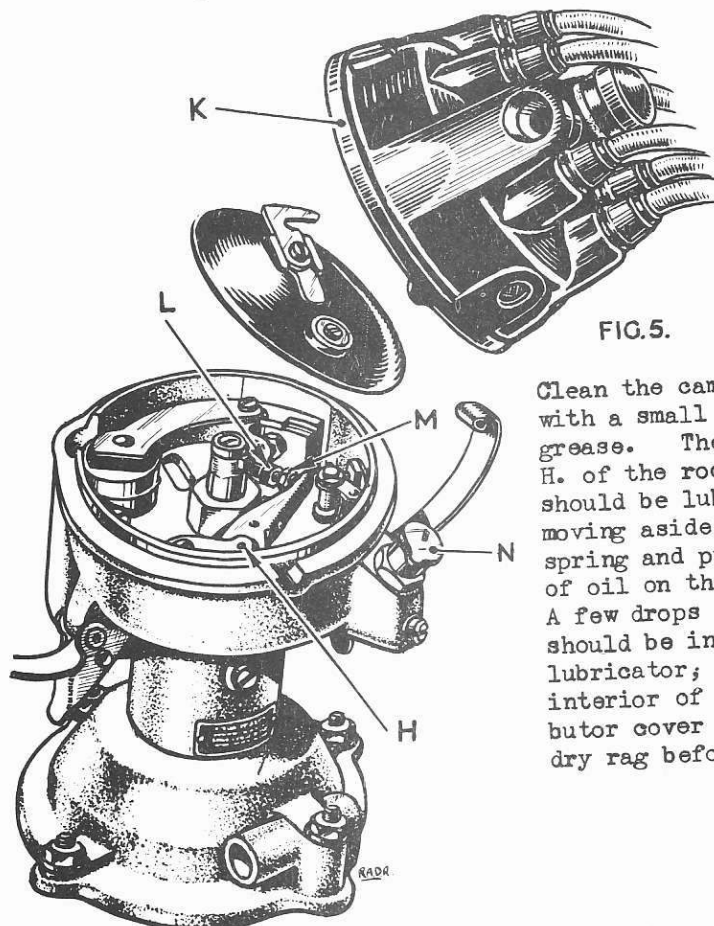

FIG. 5.

Clean the cam and smear with a small quantity of grease. The pivot pin, H. of the rocker arm should be lubricated by moving aside the retaining spring and putting a drop of oil on the exposed end. A few drops of engine oil should be injected into lubricator, N. Wipe the interior of the distributor cover with a clean, dry rag before replacing.

Continued :-

(c) Plugs.

Clean and set gaps to .018" - .022". Replace in engine and connect high tension leads.

(d) Ballast Resistance and Coils.

Remove the coil cover and clean top of coil with dry rag. Check and clean all connections to coil and ballast resistance.

(e) Starter Motor.

No attention should be necessary apart from removing the plug in the side of the reduction gear casing and filling with engine oil until the level reaches the mouth of the plug orifice. On the earlier models a small oil cup is fitted for lubrication. Two or three drops of engine oil should be injected. Should the starter motor prove sluggish in operation, the end cover should be removed and the brushes cleaned.

7. Water Cooling System.

Screw down the greaser on the water pump gland three turns and tighten the gland nut, if necessary. The radiator can now be filled with clean, preferably soft water to about 2½ inches from the top of the filler spout. Carefully examine all the rubber connections and "Jubilee" hose clips, and replace if unsound.

Adjust the fan belt by slackening off the hexagon locknut with a spanner and screwing down the knurled nut with the fingers until one side of the belt can be moved transversely with the fingers about ¾" at a point equidistant from the pulleys. Afterwards securely re-locking the hexagon locknut.

The petrol, water and electrical systems having been checked, preparations may now be made to start the engine.

8. Engine

(a) Drain the sump. Remove the oil strainer and thoroughly clean in paraffin. If a pressure filter is fitted a new element should be obtained. Refill the sump with any of the recommended oils.

(b) Remove the rocker cover. Set the tappet clearances at .004" for both inlet and exhaust valves when cold by releasing the locknut and turning the adjusting screw until the feeler gauge, provided in the tool kit, is just free to move between the rocker and valve stem. In the case of the 3½ Litre the two tappet covers beneath the exhaust manifold should be removed in order to expose the adjusting screws.

Check each compression pressure by turning the engine with the starting handle. They should be equal; if one is weaker a sticking, or burnt valve is indicated.

(c) Start the engine and note the oil pressure and charging rate. Run the engine at a fast idling speed, i.e. 1,000 - 1,500 r.p.m. until the thermometer registers 70° C. approx. when the radiator shutters should begin to open. When 90° C. is reached they should be fully open. Check the freedom of the shutters by lifting the spring-loaded pin, releasing the lever and working the shutters by hand. If stiff lubricate the joints of the mechanism with an oil can.

Having got the engine running and checked that there are no leaks in the oil and petrol systems, the following instructions should be carried out before taking the car on the road:-

Continued :-

9. Centralised Chassis Lubricating System.

Check the oil reservoir located on the front of the dash and fill with engine oil to not less than an inch from the top of the filler cover. Give the foot-operated pump a few strokes, and check that oil is reaching the various lubrication points.

Clean, and if necessary renew the felt strainers in the non-return valves on the front axle, Fig.6.

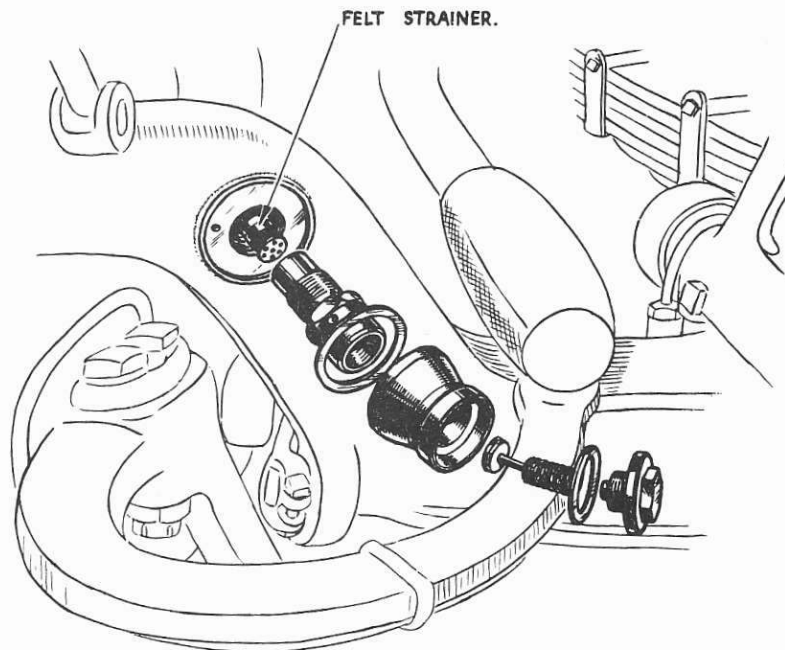

FIG. 6

10. Gearbox and Transmission.

(a) Gearbox.

Remove the two plugs and drain off the oil. Refill with engine oil to the correct level.

(b) Propellor Shaft.

Turn the shaft until the plug on the front universal joint is at the top and the lubricator at the bottom. Remove the plug and inject grease through the lubricator until it commences to flow from the plug hole. Replace the plug and repeat for rear universal.

(c) Back Axle.

Drain off oil and refill to overflow plug with Wakefield's "Hi-Press" oil.

(d) Wheel Hubs.

Jack up each wheel and remove in turn. Clean and grease the serrations and screw threads of the hub, the wheel and cap. Replace wheel and tighten cap.

Continued :-

11. Steering.

Remove plug on steering box and refill with engine oil to mouth of plug orifice. Check all bolts and nuts on the steering linkage for tightness.

12. Shock Damper System.

Remove plug on top of each damper casing and fill with either Wakefield "Castrolite", or Vacuum Mabiloil "Artic". Use the same type of oil to fill the pump and governor casing mounted on the gearbox.

13. Brakes.

(a) Lubrication.

The centralised chassis lubrication system deals with most of the brake mechanism. A spring-lid lubricator is provided for the outer bearings of the servo. Two or three drops of engine oil should be injected. In addition there is a number of joints and links of the rods and levers, which should be lubricated with engine oil.

(b) Foot Brakes.(Front and Rear).

Screw down the wing nuts with the fingers only. Each wing nut is self locking at every half turn. If the wheel is jacked up it will be easier to feel when the shoes make contact with the drum. The nut should be screwed down until the cam action of the wing nut prevents further rotation with the fingers owing to the shoes being in contact with the drum. The setting will then be correct and the adjustment locked if the nut is turned back one quarter of a turn.

(c) Hand Brake.

With the hand brake right off, the adjustment should be tested by pulling the inside brake rope situated beneath the rear axle. The travel necessary to apply the brake should not be less than $\frac{5}{8}$ ".

14. Clutch.

Remove the clutch housing inspection plate and lubricate the trunnion with an oil can, also the clutch pedal linkage. Test for correct freeing of the clutch by starting the engine and attempting to engage first gear.

In the unhappy event of the clutch having seized due to the pedal not having been jacked out during storage, it may require relining. Before carrying this out, however, the following method of freeing the clutch should be tried.

Remove the inspection cover. Start up the engine and run long enough to warm the clutch. Stop the engine and inject a small quantity of acetone into the clutch housing, so that it gains access to the clutch liners. Altogether as much as two eggcupfuls may be used. Allow a reasonable amount of time for it to soak in. Jack up the rear wheels, engage second gear and start the engine. Depress the clutch pedal and firmly apply the brakes keeping the engine running. If not effective repeat at intervals of a few days.

If the clutch frees by this method, the car may be road tested and all controls checked.

SERVICE INSTRUCTION LEAFLET

ISSUED BY
BENTLEY MOTORS (1931) LTD.



BM/A2

SB.1/IP.

Subject :

Chassis Series Data.
3½ and 4¼ Litre Bentley.

Date
of 1st April, 1946.
Issue

The Bentley system of numbering Chassis does not lend itself readily to recognising any particular sequence, and it may therefore be impossible to differentiate between different series, or to recognise where any important design change has taken place, without a key to the system of numbering.

In order to deal adequately and intelligently with the various problems in servicing these cars, which will crop up from time to time, it is necessary to publish this key. The sequence of Chassis numbers on both 3½ and 4¼ litre Bentley models is given below, together with details of any important design change which took place within these series.

This information is strictly confidential.

IMPORTANT

THE CONTENTS
OF THIS
DOCUMENT ARE
STRICTLY
CONFIDENTIAL
AND ARE NOT
TO BE
TRANSMITTED
TO ANY
UNAUTHORIZED
PERSON.

3½ LITRE

Serial Letters.	Series.	New Features Incorporated.
B-AE B-AH	A	Centre Point Radiator Mounting-B-33-AE.
B-BL B-BN	B	
B-CR B-CW	C	Drilled up Con.Rods; Controlled Dampers-B-1-CW.
B-DG	D (1-100)	Concealed Front Cross-member; Clutch Spring Drive deleted; Dunlop Road Wheels.
B-DK	D (101-200)	Rear Axle Oil Seal-B-87-DK.
B-EF B-EJ	E	R.W. Road Wheels; Geared Starter Drive; Light Flywheel and Clutch.
B-FB B-FC	F	Isolated Gear Lever; W.B. Bumpers.

4¼ LITRE

Serial Letters.	Series.	New Features Incorporated.
B-GA B-GP	G	3.5" Bore Engine; Borg and Beck Clutch; Air Cooled Dynamo; Filters on Rear Cross-member.
B-HK B-HM	H	
B-JD B-JY	J	
B-KT B-KU	K	De-turbulated Cylinder Head-B-1-KU; Short Pendulum Lever B-175-KU.
B-LS B-LE	L	Open Type Fuses-B-63-LE.
B-ME B-MY	M	Over-drive Gearbox; 6.50 x 17 Tyres; 10 x 4.3 Rear Axle; Marles Steering; Thermostat with Dummy Shutters.

SERVICE INSTRUCTION LEAFLET

ISSUED BY
BENTLEY MOTORS (1931) LTD.



BM/A3

SB/GF.2/SF.

Subject : THE STORAGE OF CARS
APPLICABLE TO ALL PRE-WAR CARS.

Date of Issue
14th October 1947

The information contained in this leaflet is for the assistance of Retailers in dealing with the storage of Bentley cars.

The additional experience gained during the war years has been included in this leaflet, which will, therefore, if carried out fully, give a reasonable safeguard against storage deterioration. On the other hand, it is of course, obvious that much will depend upon conditions in the actual place of storage, and the regularity of inspection and attention to parts of the coachwork and chassis which may be attacked by mildew, rust and other causes of damage.

The maintenance of a satisfactory condition of paintwork and upholstery can only be assured if immediate action is taken against incipient deterioration. Paint blisters and small rust patches, if allowed to spread, will lead to more trouble than is visibly apparent by creating a layer of corrosion between panels and primer. Similarly, mildew formation will occur under leather pleats and folds where its action may proceed unchecked until the leather and stitching rot. The chassis is also subject to the same form of gradual destruction, which can only be held in check by application of paint or lubricant.

It is, therefore, clear that it is not sufficient merely to carry out the instructions in this leaflet, and subsequently to assume that a car will retain its original condition without further attention. It is particularly emphasised that a continuous periodic inspection should be carried out throughout the period of storage.

With reference to particular items in the Storage Instruction, it will be noted that the petrol system should be completely drained and dried out. This is an important operation which will prevent the formation of the gum deposit which was the cause of so many difficulties after previous storage periods.

Under Item 3, we recommend that the cooling system should not be completely drained but should be filled with an anti-freeze solution. Provided that the solution strength is adequate to prevent freezing, the system will be protected against the corrosion which is liable to occur if it is empty. Aluminium castings are particularly susceptible, especially if the car is stored in a coastal district. On the other hand, anti-freeze solutions which contain Ethylene Glycol are more "searching" than plain water, so that the possibility of leakage is somewhat increased if corrosion has already taken place, as is likely on older cars. If therefore, the cooling system is known to be doubtful, and reconditioning is not practicable, it is preferable to leave it empty.

Item 8 - Hydraulic Jacks. This type of jack deteriorates if left inoperative for long periods. The sealing rubbers harden, causing leakage and unsatisfactory operation. The only way to keep them in good condition is by periodic operation.

Bodywork - Item 3. Calcium Chloride Crystals may be kept in a small open container on the floor of the car. They will absorb moisture fairly rapidly and will need replacement when saturation is reached. This method will only be fully effective if the body can be sealed from the

IMPORTANT

THE CONTENTS
OF THIS
DOCUMENT ARE
STRICTLY
CONFIDENTIAL
AND ARE NOT
TO BE
TRANSMITTED
TO ANY
UNAUTHORIZED
PERSON.

outside air, and as this cannot be done hermetically, it follows that efficiency will only be proportional to the degree of sealing attained. A heated garage, is of course, the best protection.

DETAILED INSTRUCTIONS FOR STORAGE:

CHASSIS.

1. In order to facilitate the draining of the engine crankcase, gearbox and rear axle, the car should be run for a sufficient mileage to ensure that the oil in these units has become thoroughly warmed and fluid.

PETROL SYSTEM:

2. Completely drain the main petrol tank, and where fitted, the auto-vac of all liquid petrol. Run the engine until all the petrol in the carburetters, petrol pump, fuel strainers and feed pipes has been completely used. The use of a tyre inflating compressed air line to blow out the feed pipes will ensure that no petrol remains in these units. Remove such items as the carburetter, petrol pump, and filters, thoroughly clean and refit, thus ensuring that no chemical deposit or action will take effect in the petrol system during the storage period. The main tank petrol unit should also be withdrawn, cleaned and lubricated, and if means are available, it is advisable to spray the interior of the petrol tank with a thin film of oil to act as a deterrent against the formation of rust during the storage period. The petrol gauge unit should be refitted.

COOLING SYSTEM:

3. If plain water is being used as the cooling agent, we recommend the complete draining of the system, and the substitution of an anti-freeze mixture. If, on the other hand, the water system already has anti-freeze mixture, do not drain, but if found to be of insufficient strength owing to dilution, the percentage of anti-freeze additive should be increased to a point which will ensure protection against the lowest temperature which may be expected. All rubber joints should be carefully examined, and if doubtful, renewed, and careful examination for leaks should be made at regular intervals during the storage period.

TYRES:

4. Jack up complete vehicle, taking all weight off the tyres, and place wooden blocks under the axles (for those cars having independent front suspension, place these blocks under the stub axles). Do not deflate the tyres, but maintain a reasonable pressure throughout the storage period, and keep covered up to exclude the light, which is injurious to rubber when not in actual use.

ENGINE, GEARBOX AND REAR AXLE:

5. The engine crankcase, gearbox and rear axle should be completely drained of all old oil, and refilled to the working levels with one of the recommended mineral oils as shown on the attached chart. In this manner, the effects of corrosion within these units during the storage period will be minimised, but it is essential that prior to the recommissioning of the car, this oil is completely drained off, and the units refilled with the recommended working grade of lubricant. A label bearing the statement that these units are filled with a pure mineral oil should be prominently displayed to serve as a reminder of that fact.

6. When the engine is cold, remove the sparking plugs, and inject two tablespoonsful of pure mineral oil through the plug holes into each cylinder.

Using the starting handle, turn the crankshaft a few times to distribute the oil over the cylinder walls. Remove the valve rocker cover, and treat the rocker mechanism with the same mineral oil. Replace the sparking plugs and screw them down lightly.

7. The engine, gearbox and rear axle should be revolved by hand at least once every seven to ten days. To accomplish this, remove the sparking plugs, and either by leaving the clutch jacked out, turning the engine by means of the starting handle, and then winding round one of the rear wheels with first gear engaged, or by letting in the clutch, engaging first gear, and winding the engine gearbox and rear axle by means of the starting handle.

NOTE: Under no circumstances should the engine be permitted to run under its own power during the storage period.

JACKS:

8. The hydraulic jacks, where fitted, should be operated at least once a month to prevent deterioration of the oil seals.

CLUTCH:

9. The clutch should be jacked out by placing a length of wood between the clutch pedal and the steering column bracket. This will prevent the clutch fabrics from adhering to the face of the pressure plate.

BRAKES:

10. The handbrake lever should be left in the "OFF" position.

BODYWORK.

PAINTWORK:

1. Wash down the bodywork, using clean running water and dry thoroughly. All rust patches and blisters should receive immediate attention to prevent further deterioration to the paintwork during the storage period, and we recommend the application of a good class of polish, e.g. Belco No.7., in order to maintain the general condition of the paintwork. It is recommended that periodic applications at regular intervals of between 6/8 weeks be given, in this way the danger of the formation of "Bloom" on the paintwork during the period of storage will be minimised. All bright parts not having an untarnishable finish should, after being cleaned, be lightly smeared with vaseline. (The use of vaseline on parts having a chromiumed finish is both unnecessary and undesirable).

UPHOLSTERY:

2. All carpets, cushions and interior upholstery should be thoroughly brushed out and cleaned and liberally sprinkled with one of the anti-moth preparations available. After this treatment, all carpets, cushions and other detachable items should be stored in such a manner as to prevent further attack by moth, where they should be examined at regular intervals, and if found necessary, retreatment should be carried out. All leather upholstery should be given an application of "Connolly's Hide Food" to enable it to retain its suppleness and freshness during the storage period.

STORAGE:

3. Providing the place of storage is dry, all windows on the car, should be kept slightly open to assist in the circulation of fresh air within the body. If, however, the place of storage has a tendency towards dampness, and there is

danger of moisture collecting within the body to the detriment of the upholstery, it is suggested that some form of anti-moisture preparation e.g. Calcium Chloride Crystals, be utilised. It should, however, be noted that these preparations absorb moisture from the immediate atmosphere, and therefore, it will be necessary to keep all windows, doors and other means of ventilation on the vehicle firmly closed, to prevent rapid absorption of moisture, and subsequent saturation of these crystals. Periodical inspections of the crystals at regular intervals should, therefore, be given, and when seen to be near saturation point, a fresh supply should be furnished.

4. Where the car is an open model, the hood should be erected and extended.
5. Cover the complete vehicle with a light dust sheet.

NOTE: The place of storage should be DRY, DARK, WELL VENTILATED AND PREFERABLY HEATED.

ELECTRICAL.

BATTERY:

1. Car batteries tend to deteriorate quickly when not in use unless provision is made for their maintenance. An unattended battery may become completely ruined in a few months, and even under the best conditions of storage, a fully charged battery will deteriorate slowly. Assuming that the battery is in a sufficiently good condition to make storage an economical proposition, a choice between the two well tried methods detailed below is recommended.

PERIODICAL FRESHENING CHARGE:

2. Remove the battery from the car, clean thoroughly, top-up with distilled water and give a thorough charge at the normal rate recommended by the makers. Administer a freshening charge at the same rate at regular intervals of 4/6 weeks, continuing each of these charges until the specific gravity of the acid has remained constant for about 10/12 hours on each occasion.

WASHING OUT AND STORING FILLED WITH DISTILLED WATER:

3. Remove the battery from the car, clean thoroughly and top-up with distilled water, and give a thorough charge at the rate recommended by the makers. Empty out the free acid and refill cells with three successive changes of clean distilled water, allowing the water to remain in the cells for at least an hour before each change. Finally, fill up the cells with distilled water, replace and tighten the vent plugs ensuring that the outside of the battery is dry and clean. The battery may now be placed into storage for the whole of the storage period without further attention, but it is essential that it is not exposed to the risk of freezing during the winter months. The place of storage should be between the limits of 40°F. to 80°F.

NOTE: Continuous trickle charging is not recommended, and will, after a relatively short period, cause rapid deterioration of the battery.