

Faint, illegible text, possibly bleed-through from the reverse side of the page.

**REAR AXLE AND
DRIVE SHAFTS**



SERVICE INSTRUCTION LEAFLET

ISSUED BY

BENTLEY MOTORS (1931) LTD.



BM/K1

SB/AK.1/SF.

Subject :

REAR AXLE: BEVEL PINION OVERHAUL.
3½ AND 4¼ LITRE MODELS.

Date
of
Issue

10th October, 1946.

This leaflet, BM/K1, will deal solely with the rear axle pinion assembly, while a later leaflet, BM/K2, will cover the fitting of a new crown wheel and pinion and the overhaul of the rear axle assembly.

The rear axles fitted to all chassis in the 3½ and 4¼ Litre series are of the fully floating type having hypoid bevel gears, which in addition to their inherent quietness and load carrying capacity, allow a lower floor line to be obtained. The standard axle ratio is 10:41, but under special order an 11:43 ratio can be fitted. On the MR and MX series of the 4¼ Litre chassis the standard ratio is 10:43.

The Bentley 3½ and 4¼ Litre models were designed as high performance sports cars, and as such it was essential that the weight of the rear axle be reduced to a minimum in order to obtain a low unsprung weight. The components of the axle are therefore subjected to high stresses, which although not injurious in themselves, can, in conjunction with the stresses imposed by any maltreatment of the car on the road, result in overloading certain parts of the axle.

Probably the most heavily loaded component is the pinion thrust bearing, failure of which will be indicated by oil leakage from the pinion assembly, and/or noise from the rear axle. This will necessitate the removal of the pinion assembly, which can be effected without disturbing the setting of the crown wheel, or removing the rear axle from the chassis. With the rear axle jacked up, remove the propeller shaft, front end first, and the ring of nuts securing the pinion assembly to the axle centre casing. The pinion assembly, (Fig.1), can then be withdrawn from the axle centre casing, secured in the holding block (Tool No. R3019), in a vice, and dismantled as follows:-

1. Remove the driving flange retaining nut and lockwasher, and pull off the driving flange (A) and cover plate (B), using an extractor, (Tool No. R2962 or R2963), whichever is applicable.
2. Knock out the two keys (C), and lift off the coil spring (D), locking plate (E), and oil retainer ring (F).
3. Remove the thrust bearing retaining nut (G), (L.H. Thread), using the serrated spanner, (Tool No. R2974).
4. Remove the remainder of the assembly from the holding block, place on a suitable tube, and press out the pinion (H). The thrust bearing (J) can then be driven from the housing (K).

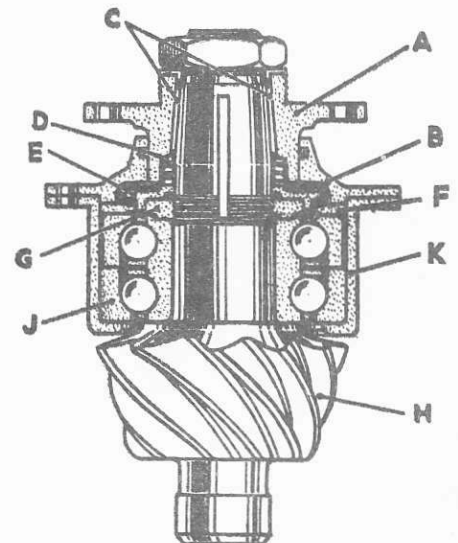

IMPORTANT

THE CONTENTS
OF THIS
DOCUMENT ARE
STRICTLY
CONFIDENTIAL
AND ARE NOT
TO BE
TRANSMITTED
TO ANY
UNAUTHORIZED
PERSON.

Continued:

RM/K1.

INSPECTION OF PARTS AND RE-ASSEMBLY.

The most important feature of the pinion assembly is the fitting of the latest type thrust bearing, Part No. GB4080, (See Fig.2), and the modifications entailed. This bearing must be fitted as a replacement whenever an earlier type bearing is encountered or a renewal is necessary. In conjunction with the new bearing, the modified oil retainer ring, Part No. GB2704, and bearing retaining nut, Part No. GB.1134, must also be fitted.

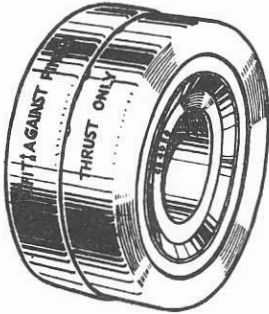

Fig. 2.

The outer track of the thrust half of the bearing, marked "THRUST ONLY", is free in the housing to ensure that it receives no radial load, while a 0.001" preload, provided in the design of the bearing and automatically applied when the bearing is nipped between the end of the housing and the oil retainer ring, against which the lip on the cover plate bears, produces a deflection of the bearing equivalent to the calculated deflection when the pinion is under load, thus enabling the bearing to run without distortion.

In order to prevent the bearing moving in the housing and to simultaneously apply the preload, a pinch is applied to the bearing when the assembly is secured to the rear axle casing. To provide this pinch there must be a clearance of .002" - .003" between the joint faces of the housing and cover plate when the bearing and oil retainer ring are in position before the nuts on the cover are secured. Where the new bearing replaces the early type (G54269) it will be necessary to machine the lip on the cover plate in order to accommodate the greater width of the new bearing. The amount to be removed can be measured by means of a feeler gauge between the joint faces of the housing and cover plate, and during the machining the clearance should be checked at diametrically opposite points to ensure that the joint faces are parallel, as it is essential that the load on the "THRUST ONLY" outer track of the bearing be evenly distributed.

If the new type bearing is already fitted it should be thoroughly cleaned and tested to ensure that excessive wear has not taken place. The bearing must be renewed if any play of the inner track can be felt when the outer tracks of the bearing are nipped together in a vice. As a second check, the bearing should be opened and the balls, tracks and cages inspected for pitting or damage, as this will necessitate the fitting of a new bearing.

Any slackness of the driving flange on the pinion will be indicated by marks on the pinion and driving flange tapers in addition to key damage. If light lapping of the flange on to the pinion taper is insufficient to remove these marks, the flange and/or pinion must be renewed as necessary. The flange must be renewed if the grooves of the oil return scroll are damaged, while new keys will be required if the original pair show any signs of damage or slackness in the keyways.

Before assembly, a new driving flange should always be lapped onto the pinion taper, and marking blue used to check that it is in complete contact with the taper. The keys should then be made a good fit in the pinion keyways, and the driving flange replaced on the taper. Marking blue must again be used to check that the seating of the flange is not obstructed by the keys. When this has been done, replace and secure the driving flange retaining nut, and check that the contact face of the flange is running true with the pinion. If the flange is running out, it must be machined as necessary. This procedure should be carried out in all cases. A magnetic crack detector should be used to test the pinion, and the teeth examined for pitting or scoring, as renewal will be necessary if this is excessive.

Continued:

EM/K1.

The keys and their corresponding sides of the driving flange and pinion are numbered 1 and 2, and any of these parts that are renewed must be numbered after fitting, to ensure correct re-assembly.

For general overhaul, a new felt oil seal, Part No. GB581, must be fitted in the cover plate.

If the pinion is now secured in the holding block, the final assembly can be carried out as follows:-

1. Place the bearing and housing over the pinion taper, and tap down into position.
2. Screw down the bearing retaining nut, (L. H. Thread) plain side uppermost.
3. Check that the projections on the locking plate fit in the nut serrations, place the oil retainer ring against the bearing, and fit the locking plate.
4. Place the coil spring over the pinion taper, and fit the keys, by depressing the spring.
5. Position the six bolts in the driving flange, smear a little grease on the felt in the cover plate, and push the flange into the cover. This assembly can then be placed on the pinion taper and driven into position. Due to the individual fitting during manufacture it may be found that after re-assembly the driving flange will bed down on the coil spring, and thus be held off the pinion taper. It is therefore advisable to check that the flange is correctly seated when the spring is in position. If necessary the ends of the spring can be ground down and the fitting re-checked until correct.

The driving flange lockwasher and retaining nut can then be finally secured, and the pinion assembly fitted to the axle casing, with the original packing washer between the bearing housing flange and the casing. Owing to irregular stud spacing there is only one position in which the packing washer and pinion assembly will pass over the studs.

SERVICE INSTRUCTION LEAFLET

ISSUED BY
BENTLEY MOTORS (1931) LTD.



BM/K2

SB/VK. 1/RS.

Subject: REAR AXLE FITTING THE CROWN-WHEEL & PINION.
BENTLEY $3\frac{1}{2}$ LITRE & $4\frac{1}{4}$ LITRE MODELS.

Date
of 18th January, 1955.
Issue

GENERAL:

When the renewal of these components becomes necessary, the Rear Axle Assembly should be returned to this Service Station. If this is not possible, the overhaul may be carried out by competent personnel where the special tools and facilities required are to hand.

TOOLS:

To position the crown-wheel and pinion correctly, a pinion setting tool is indispensable but should the tool not be to hand, a suitable arrangement must be fabricated. The appended drawing gives details of simplified equipment which may be produced where turning facilities are available.

In addition, a pair of V-blocks, a dial test indicator, a surface plate and an early pattern Duplex bearing are needed. (Hoffman 340.CD split outer race).

IMPORTANT

THE CONTENTS
OF THIS
DOCUMENT ARE
STRICTLY
CONFIDENTIAL
AND ARE NOT
TO BE
TRANSMITTED
TO ANY
UNAUTHORIZED
PERSON.

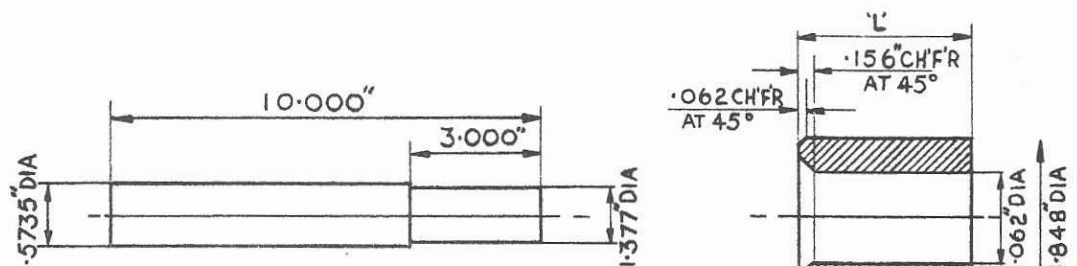

THE DIMENSION 'L' IS CALCULATED BY
SUBTRACTING THE RADIUS OF THE MANDREL
FROM THE DIMENSION ETCHED ON PINION NOSE.

ASSEMBLY:

1. FITTING THE CROWN-WHEEL TO THE DIFFERENTIAL CASING.
 - (a) Bolt the two halves of the differential casing together without the axle shaft or planet wheels; leave the nuts unpinned.
 - (b) Examine the crown-wheel and the differential casing for cleanliness and burrs and bolt them together, leaving the nuts unpinned. Fit the bearings to the differential casing using the Modified Duplex bearing (Hoffman 340.CD or R & M. DMTT4OJ. Both split inner races). Replacements are available from this Service Station.

- (c) Mount the assembly on a pair of V-blocks and with a dial test indicator, check the axial run-out of the crown-wheel. If this exceeds .002" examine the wheel and casing and rectify the cause of incorrect seating.
 - (d) Split-pin the crown-wheel nuts.
 - (e) Remove the bearings.
2. Assemble the pinion and thrust bearing in accordance with Leaflet BM/K1.
3. PINION SETTING.
- (a) Remove the pinion nose bearing from the axle casing.
 - (b) Fit the off-side bearing to the axle casing. On all cars except M-Series, tighten and split-pin the nuts. On M-Series cars see that the oil seal carrier is in position and the bolt ends peaned over.
 - (c) Assemble the bearing housing to the carrier plate and fit the distance washer and Duplex bearing into the housing, for this purpose use the early type bearing with the two-piece outer track. Bolt the assembly to the axle casing.
 - (d) Pass the mandrel through the bearings.
 - (e) Position the distance piece on the pinion nose end, with the original washer in place, chamfer downwards, on the housing, push the assembly into the axle casing until the nuts can be started.
 - (f) Carefully and evenly tighten the nuts and simultaneously rotate the driving flange until the effort required to turn the flange becomes greater, indicating that the distance piece is in contact with the mandrel. It is important to discriminate between this tightening up and the normal heaviness of the pre-loaded pinion bearing. With feeler gauges measure the clearance between the flange of the housing and the axle casing. If during this trial fitting all clearance at the flange is taken up without the distance piece making contact with the mandrel, withdraw the pinion assembly, fit a thinner washer under the flange and repeat the trial until clearance is obtained. Then withdraw the pinion assembly, and with a micrometer measure the thickness of the washer. Add this dimension to the feeler gauge reading and place a washer of precisely the same thickness, chamfer downwards, over the pinion housing.
 - (g) With the distance piece still in position bolt the pinion assembly tightly into the axle casing and note that this distance piece is still in contact with the mandrel as before.
 - (h) Withdraw the pinion assembly and remove the distance piece.
 - (i) Withdraw the mandrel and remove the carrier plate assembly.
 - (j) Fit the pinion nose bearing to the axle casing and split-pin the nuts. On all chassis up to the end of L-Series, pinions of a modified type are supplied as replacements and in all such cases the later type pinion nose bearing must be fitted.

- (k) With the selected washer in position against the flange, fit the pinion assembly and fully tighten the securing nuts.
4. Assemble the Differential planet wheels and Axle shafts as described in Leaflet EM/K3.
5. FITTING THE CROWN-WHEEL AND DIFFERENTIAL ASSEMBLY.

The crown-wheel/pinion backlash is controlled by the distance washer between the Duplex bearing and the housing, and adjustment is effected by varying the thickness of this washer. A thicker washer decreases the backlash.

The correct backlash for a given pair of bevels is etched on the back of the crown-wheel, and is usually in the range .006" - .008".

- (a) Take the nearside bearing housing to which the carrier plate has already been assembled; (in the case of M. Series cars see that the backing plate and axle tube bolts are in position). Place the distance washer, rounded edge downwards, in the housing and follow it up with the Duplex bearing, the locking plate and the bearing housing nut, fully tighten and lock.
- (b) Assemble the carrier plate assembly onto the nearside of the differential casing, position the plain washer and lock washer on the thread and fully tighten and lock the differential casing nut. On chassis to the end of L-Series fit the plain washer, lock washer and nut to the offside end of the differential casing, tighten and lock. On M-Series cars this nut is dispensed with and a collar pressed onto the differential casing behind the offside bearing. In these cases care must be taken to ensure that when the carrier plate is tightened down the collar does not take up the side clearance of the bearing. Should this condition arise, the outer face of the collar must be skimmed to give the correct clearance to the bearing.
- (c) Enter the offside of the differential casing into its bearing and tap it up into position. As the casing is pushed into the bearing the carrier plate will engage on the axle casing studs. When the differential casing is fully home, fit the spring washers and nuts to the studs and tighten evenly. Ensure that the crown-wheel and pinion are not jammed in the course of this by frequently checking at the driving flange for backlash. Fit washers and nuts to six of the offside axle tube bolts. Attach the nuts to alternate or every third bolt, according to the chassis series. This ensures that the bearing housing is correctly bedded on the carrier plate.
- (d) To check the backlash in the assembly, mount the dial test indicator on the casing so that its spindle bears tangentially on the driving flange stud. Note the backlash at this position and then by rotating the flange anti-clockwise, take readings at intervals of 120° until four revolutions of the flange have been completed. The average of the readings obtained should coincide with the figure etched on the crown-wheel with a tolerance of + .005". It may be found that the backlash varies as much as .006" from reading to reading but this is of no moment provided the average figure is within limits. Should adjustment be necessary the assembly must be dismantled back to para. (a) above and a washer of different thickness fitted behind the Duplex bearing; a difference of .001" in the washer thickness alters the backlash about .002".

When the correct backlash has been obtained, it remains to fit the nearside oil seal, in the case of M-Series chassis, and to complete the axle assembly in accordance with Leaflet EM/K3.

SERVICE INSTRUCTION LEAFLET

ISSUED BY

BENTLEY MOTORS (1931) LTD.



BM/K3

SE/BB.1/SF.

Subject :

REAR AXLE - PROCEDURE FOR FITTING REAR
AXLE SHAFT. BENTLEY $3\frac{1}{2}$ AND $4\frac{1}{4}$ LITRE.

Date
of
Issue

21st March, 1952.

IMPORTANT

THE CONTENTS
OF THIS
DOCUMENT ARE
STRICTLY
CONFIDENTIAL
AND ARE NOT
TO BE
TRANSMITTED
TO ANY
UNAUTHORIZED
PERSON.

This Service Instruction Leaflet is intended as a guide to the procedure adopted whenever it is found necessary to fit a new pair of axle shafts to the above models.

All axle shafts now supplied are of a modified pattern and it is advisable to fit a pair, as it has been found by experience that the opposite shaft may be in an advanced state of fatigue and is likely to fail.

The car should be jacked up and the chassis supported by suitable trestles. Both rear hubs can then be removed in accordance with Service Instruction Leaflet BM/V.1., and the propellor shaft detached. Opportunity should be taken to examine and attend to the propellor shaft damper where fitted.

Having first removed the clevis pins from the brake cables, disconnected the shock absorber arms, and removed the 'U' bolts, the whole axle can be removed from the car, and the oil drained.

The pinion assembly securing nuts on the axle nose-piece may be removed, and the assembly pulled away from the axle centre casing. The left-hand axle tube and oil sealing housing is then withdrawn from the main casing.

The differential end plate can be removed from the centre casing, and the right-hand axle shaft knocked through, allowing the left-hand axle shaft complete with the differential assembly to be removed. This assembly should be secured in a vice with the end plate upwards.

Next remove the retaining nut, lock washer and plain washer and pull off the end plate. Mark the two sections of the differential casing to ensure correct assembly, and dismantle the unit, noting the position of the various spacing washers.

After all the parts have been washed off, examined and crack tested, the four pinions can be mounted on their respective trunnion shafts. These should form a good mitre when in position.

The trunnion and casing should next be marked to ensure its position on final assembly. With the trunnion assembly in position, mount one axle shaft in the half casing and bolt up the other half casing, checking for end float of the shaft, (there should be only a normal running clearance). The end float is controlled by the thickness of bronze washers between the axle shaft pinion and the differential housing.

This operation is repeated with the other shaft.

With the trunnion assembly removed, both shafts are replaced in the differential casing with the small centre distance piece between them, and the casing is then bolted together and the shafts checked for end float. As before, there should only be a running clearance.

The unit is then assembled in the normal manner and fitted to the axle casing.

N.B. When replacing the hubs, it should be observed that there is at least .015" clearance between the distance piece immediately behind the axle shaft nut and plain washer (P.i. Fig.5, BM/VI) to ensure that the axle shaft nut is not putting undue stress upon the Duplex bearing in the axle casing.

The pinion assembly is dealt with as a separate unit under Leaflet BM/K.1.

Short Axle. LH G 51040

Long Axle RH G 51041