

Airconditioning - Climate Control - All SY Cars

Also applies to rationalising the STV or EEVIR/POAST systems on SZ cars to Chassis 16,570

Suction throttling valve

Applicable to

Rolls-Royce
Silver Shadow
Silver Shadow Long Wheelbase
Silver Wraith II
Phantom V and VI

Bentley

T Series between car serial numbers SBX 1001 to SRX 30000

Introduction

The suction throttling valve fitted as original equipment and the unit which was supplied as a replacement are no longer available.

Description

This Product Support Information Sheet describes the procedures for fitting a kit of parts for servicing all motor cars in the above car serial number range.

Procedure

- 1.) Remove the suction throttling valve as described in TSD 2476 Workshop Manual, Section C.
- 2.) Dismantle the suction throttling valve and discard the following items (see fig.

C9-1

C9-1 Suction throttling valve

1	Pressure adjusting nut
2	Centre spindle
3	Screw
4	Valve cover
5	Rivet
6	Operating arm
7	Operating arm springs
8	Main spring seat
9	Main spring
10	Locating spring
11	Regulating spring seat
12	Regulating spring
13	Spacing washer
14	Main spring seat
15	Piston and diaphragm assembly
16	Filter screen
17	Filter screen retainer
18	Valve body
19	Valve cap (if fitted)
20	Schrader valve (if fitted)
21	Schrader valve adapter (if fitted)
22	Sealing ring
23	Charging pipe
24	Cap

C9-1). Schrader valve (Bleed line) Piston and diaphragm Main spring and spring seat Pressure adjusting nut Centre spindle
Operating arm and arm springs

- 3.) Discard the actuator crank lever and the link rod from the suction throttling valve.
- 4.) Lightly coat the gasket which is provided with refrigerant oil, fit the gasket, blanking plate, valve cover and secure with the screws from the diaphragm cover.
- 5.) Refit the modified suction valve onto the vehicle as described in TSD 2476 Workshop Manual, Section C
- 6.) Using the metal clip, secure the sensor tubes from the thermostat and expansion valve to the low pressure outlet pipe and wrap the sensor tubes with the insulation tape provided

C9-2 Evaporator pipes and suction throttling valve C9-2).

- 7.) Mount the thermostat in a suitable position on the left-hand valance (the position will be determined by the length of the sensor tube) with self-tapping tubes.
- 8.) Connect the original wire from the compressor to the terminal (marked cut in) of the thermostat using the terminal provided.
- 9.) Connect the link loom to the terminal of the compressor and to the terminal (marked cut out) of the thermostat using the terminal provided.
- 10. Evacuate the system and recharge as described in TSD 2476 Workshop Manual, Section C.

Parts affected

Displaced part number	Description	Quantity	New part number
CD 4900	Kit-Suction	1	CD 6687
RH 9805	throttling		
UD 11429	valve		

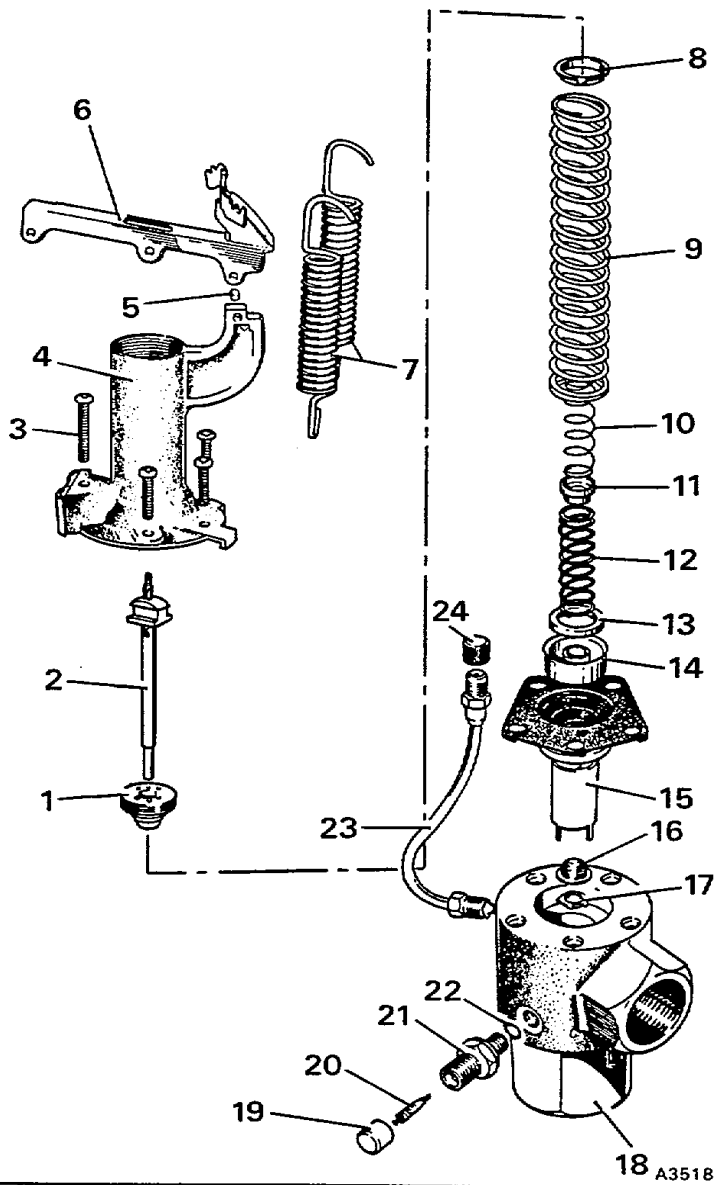

Fig.C9-1 Suction throttling valve

- 1 Pressure adjusting nut
- 2 Centre spindle
- 3 Screw
- 4 Valve cover
- 5 Rivet
- 6 Operating arm
- 7 Operating arm springs
- 8 Main spring seat
- 9 Main spring
- 10 Locating spring
- 11 Regulating spring seat
- 12 Regulating spring
- 13 Spacing washer
- 14 Main spring seat
- 15 Piston and diaphragm assembly
- 16 Filter screen
- 17 Filter screen retainer
- 18 Valve body
- 19 Valve cap (if fitted)
- 20 Schrader valve (if fitted)
- 21 Schrader valve adapter (if fitted)
- 22 Sealing ring
- 23 Charging pipe
- 24 Cap

18 A3518

