



## Special processes

### Contents

Contents	Sections						
	Rolls-Royce			Bentley			
	Silver Spirit	Silver Spur	Corniche / Corniche II	Eight	Mulsanne / Mulsanne S	Turbo R	Continental
Contents and issue record sheet	B1	B1	B1	B1	B1	B1	B1
Storage and recommissioning	B2	B2	B2	B2	B2	B2	B2
Shipping precautions	B3	B3	B3	B3	B3	B3	B3



# Issue record sheet

The dates quoted below refer to the issue date of individual pages within this chapter.

Sections	B1	B2	B3							
Page No.										
1	5/88	5/88	5/88							
2		5/88								
3	5/88	5/88								
4										
5										
6										
7										
8										
9										
10										
11										
12										
13										
14										
15										
16										
17										
18										
19										
20										
21										
22										
23										
24										

Sections										
Page No.										
1										
2										
3										
4										
5										
6										
7										
8										
9										
10										
11										
12										
13										
14										
15										
16										
17										
18										
19										
20										
21										
22										
23										
24										



## Storage and recommissioning

### Storage

To ensure the correct degree of protection the information given under the heading 'Recommended storage procedure' should be adopted.

The success of this procedure depends upon correct initial preparation, regular inspection, and maintenance.

When the car is stored always ensure that the battery master switch is turned anti-clockwise to the off position. On cars not fitted with a master switch, disconnect the battery leads.

The storage building should be dry and well ventilated. If the building is heated, the temperature must remain constant.

On Convertible cars, ensure that the hood is raised with the hood clips securely fastened.

**Throughout the storage period, the following recommended storage procedure should be carried out every two weeks.**

### Recommended storage procedure

1. Inspect the coolant hoses. If any are found to be defective, report them to the Owner.
2. Check the engine coolant level and top-up if necessary.
3. Ensure that the fluid levels in the engine sump, torque converter transmission, steering pump, final drive unit, and the braking and levelling system reservoirs are to the maximum level marks; top-up if necessary.

On Convertible cars, also ensure that the fluid level of the power operated hood reservoir is to the maximum level mark.

**It must be noted that the braking and levelling systems of the car are filled with hydraulic system mineral oil. When filling or topping-up the reservoirs it is important that the correct oil is used.**

4. Check the tyre pressures including the spare and adjust if necessary (See Chapter R).
5. Ensure that all controls, instruments, warning panels, and lamps are operating correctly.
6. Run the car for a minimum of 16 kilometres (10 miles) to ensure complete lubrication of the internal components.
7. Allow the car to cool, then thoroughly wash the exterior bodywork as described in Chapter A. Any damaged paintwork discovered during this operation should be reported to the Owner.
8. On initial storage, apply a good quality cleaner/polish followed by a good quality wax polish. Also thoroughly clean the carpets and upholstery; treat all leather upholstery with Connolly's Hide Food.
9. Cover the car with a light cotton or muslin dust sheet. It should be noted that plastic or similar materials **must not** be used for this purpose as they

can create condensation which, under certain climatic conditions, can damage the paintwork.

10. Ensure that the tyres are covered if there is a possibility of sunlight penetrating into the storage area.

### Alternative storage procedures

If it is not possible to carry out the recommended storage procedure every two weeks, the following procedures may be adopted though they will not provide the same degree of protection.

### Storage periods between one and three months

Initially, carry out the recommended storage procedure.

In addition increase the tyre pressures as follows.

Other than Bentley Turbo R cars 2,8 bar (40 lbf/in<sup>2</sup>). Bentley Turbo R cars 3,5 bar (50 lbf/in<sup>2</sup>). The pressure of the spare tyre does not need increasing.

### Storage periods between three and six months

Initially, carry out the recommended storage procedure.

The following additional measures should also be undertaken.

1. Remove the sparking plugs and inject two tablespoons of a corrosion preventive oil into each cylinder. Suitable oils are BP Energol Protective Oil 20 and Castrol Storage Oil 20. Using the ignition key, crank the engine to distribute the oil over the cylinder walls. Fit the sparking plugs.
2. Clean all chromium plating and stainless steel, then lightly smear with petroleum jelly.
3. Remove, clean, and fully charge the battery. If necessary top-up with distilled water.
4. Jack up the car and place supports under the rear trailing arms and the outer ends of the front lower triangle levers. Do not deflate the tyres.

### Storage periods exceeding six months

The following additional measures to those listed for storage periods between three and six months are recommended.

1. Drain the final drive unit and the engine sump, then fill them to the normal levels with one of the corrosion preventive oils previously quoted. Run the engine for one minute to distribute the oil.

2. Syphon the fuel tank. **Do not** run the engine to completely drain the system as damage to the fuel pump and catalytic converter (if fitted) could occur.

**Warning** It is most important that prior to working on the fuel system reference is made to the information under the heading Safety procedures.

3. Position a note on the facia stating that the fuel



- tank is empty and that no attempt must be made to start the engine until the tank contains fuel.
4. Dust the carpets and rugs with anti-moth powder and store them in a dry place.
  5. If the storage building is dry, leave the car windows slightly open.

If there is any tendency towards dampness, close the doors and windows and place an anti-moisture compound, such as silica-gel or calcium chloride, in an open metal container inside the car.

6. **Every six months**, remove, clean, and fully charge the battery. If necessary top-up with distilled water.

### Recommissioning procedure

Dependent on the procedure adopted the following points are all that should require attention before the car is roadworthy.

1. Lower the car onto its tyres. Check the tyre pressures and adjust if necessary (see Chapter R).
2. Fully charge and fit the battery. If necessary top-up with distilled water.
3. Drain any corrosion preventive oil from the engine sump and final drive unit. Fit a new engine oil filter element and then fill the engine sump and final drive unit with the approved oils (see Chapter D).
4. Check the engine coolant level and top-up if necessary.
5. Remove the sparking plugs.

If the car has not been run every two weeks during the storage period, prime the cylinders with engine oil. Using the ignition key, crank the engine to distribute the oil and to prevent a hydraulic lock.

6. Clean the sparking plugs and if necessary set the gaps (see Chapter A). Fit the plugs.
7. Ensure that the fluid levels in the engine sump, torque converter transmission, steering pump, final drive unit, and the braking and levelling system reservoirs are to the maximum level marks.

On Convertible cars, also ensure that the fluid level of the power operated hood reservoir is to the maximum level mark.

**It must be noted that the braking and levelling systems of the car are filled with hydraulic system mineral oil. When filling or topping-up the reservoirs it is important that the correct oil is used.**

8. On cars other than Bentley Turbo R lubricate the distributor by removing the rotor and applying a drop of clean engine oil to the top of the spindle.
9. Lubricate all grease points with approved grease (see Chapter D).
10. If the fuel has been syphoned, fill the tank and start the engine. Check that the engine oil pressure and ignition warning lamps extinguish. Also check for coolant, oil, or fuel leaks.
11. Check the operation of all controls, instruments, warning panels, lamps, and accessories.

**Note** Should the brake pressure warning panels remain illuminated for more than a few minutes after starting the engine, refer to Chapter G.

12. Should the battery leads be disconnected for 4 weeks or longer during the storage period, the front

seat adjustment memory function (if fitted) will be lost.

If this has occurred, it will be necessary to reactivate the memory by tapping-in the memory code as follows.

**Warning** When the seat memory is reactivated, the seat will move immediately and automatically to a set adjustment position. Take care therefore to avoid contact with the seat when carrying out the following procedure.

13. Ensure that the gear range selector lever is in the park position, then turn the ignition switch to either the ACC or RUN position.

14. Briefly depress one of the seat memory switches (MEM), situated on the centre console, five times.

Then, immediately depress the numbered store/recall buttons on the same panel in the sequence 4, 3, 3, 4.

15. To store a selected seat position in the memory proceed as follows.

Depress the switch marked MEM. This will activate the memory which will then remain receptive for a period of five seconds. During this period, press one of the four numbered personal allocation switches. The personal seat position data will then be stored in the memory until new data is programmed into the memory by repeating the procedure for a new seat position.

16. To recall the stored seat position press and hold down the personal allocation switch until the seat has reached its programmed position. Seat movement can be stopped at any time by releasing the switch. Seat adjustments that are made using the independent manually operated seat position switches will not affect the memory.

### Safety procedures

In addition to the usual workshop safety procedures note the following.

1. Extreme care must be exercised whenever any work is carried out on the fuel system. Always ensure that the no smoking rule is strictly observed and that there is either a foam, dry powder, or CO<sub>2</sub> (carbon dioxide) fire extinguisher readily to hand.

2. Fuel may contain up to 5% of Benzene as an anti-knock additive. Benzene is extremely injurious to health (being carcinogenic) **and therefore all contact should be kept to an absolute minimum, particularly inhalation.**

3. The fuel system may contain fuel under pressure. Therefore, prior to opening the system (i.e. disconnecting pipes or unions), disconnect the battery and ensure that the system is depressurized (refer to TSD 4737 Engine Management Systems Manual).

Protective clothing including safety goggles, gloves, and apron should be worn at all times by the operator.

4. Fuel has a sufficiently high vapour pressure to cause a hazardous build-up of vapour in poorly ventilated areas.

5. The fuel is irritant to the eyes and skin and any affected parts should be washed immediately with clean water. The fuel vapours are irritant to the lungs



and if high concentrations are inhaled it may cause nausea, headaches, and depression.

6. The danger from inhaling exhaust gases cannot be over emphasized. When operating the engine in a confined space or workshop, **always** ensure that the area is well ventilated. Whenever possible the exhaust gases should be ducted out of the building.

Sitting in the car with the car's air conditioning system operating will not eliminate the danger.



## Shipping precautions

When transporting a car overseas always contact a reputable shipping agent to obtain the correct advice and service. The following points should also be brought to the notice of the shipping agent.

1. If it is necessary to syphon the fuel from the tank note the following.

**Do not** run the engine to completely drain the system as damage to the fuel pump and catalytic converter (if fitted) could occur.

Position a note on the facia stating that the fuel tank is empty and that no attempt must be made to start the engine until the tank contains fuel.

2. It is of the utmost importance that service personnel should fully appreciate that the hydraulic systems of the car operate at **high pressures** and that they are fully conversant with the precautions which must be taken to ensure correct operation of the systems. Special attention should therefore be given to the items on Special Precautions in Chapters A and G.

3. Ensure that the battery is disconnected and the terminals taped up.

4. Cover all outer chromed parts with masking tape.

5. When the car is shipped in a container, place a bag of silica-gel adjacent to each wheel trim and below each suspension spring.

### Safety procedures

In addition to the usual workshop safety procedures note the following.

1. Extreme care must be exercised whenever any work is carried out on the fuel system. Always ensure that the no smoking rule is strictly observed and that there is either a foam, dry powder, or CO<sub>2</sub> (carbon dioxide) fire extinguisher readily to hand.

2. Fuel may contain up to 5% of Benzene as an anti-knock additive. Benzene is extremely injurious to health (being carcinogenic) **and therefore all contact should be kept to an absolute minimum, particularly inhalation.**

3. The fuel system may contain fuel under pressure. Therefore, prior to opening the system (i.e. disconnecting pipes or unions), disconnect the battery and ensure that the system is depressurized (refer to TSD 4737 Engine Management Systems Manual).

Protective clothing including safety goggles, gloves, and apron should be worn at all times by the operator.

4. Fuel has a sufficiently high vapour pressure to cause a hazardous build-up of vapour in poorly ventilated areas.

5. The fuel is irritant to the eyes and skin and any affected parts should be washed immediately with clean water. The fuel vapours are irritant to the lungs and if high concentrations are inhaled it may cause nausea, headaches, and depression.

6. The dangers from inhaling exhaust gases cannot be over emphasized. When operating the engine in a confined space or workshop, **always** ensure that the area is well ventilated. Whenever possible the exhaust gases should be ducted out of the building.

Sitting in the car with the car's air conditioning system operating will not eliminate the danger.

# **Section C Supplement**

## **Heating, Ventilation and Air Conditioning (HVAC)**

**This Section Refers to the**

**20000-Series Cars and Onwards**

**1987 to 2000**

**With Microprocessor Controlled Climate Control**



# Air conditioning system

Contents	Sections							
	Rolls-Royce		Corniche	Corniche II	Bentley		Continental	
	Silver Spirit	Silver Spur			Eight	Mulsanne Turbo R		
Contents and issue record sheet	C1	C1	C1	C1	C1	C1	C1	
Precautions	C2	C2	C2	C2	C2	C2	C2	
Introduction and basic operation	C3	C3	C3	C3	C3	C3	C3	
Electrical circuits test and fault diagnosis	C4	C4	C4	C4	C4	C4	C4	
Refrigeration system	C5	C5	C5	C5	C5	C5	C5	
Component description	C6	C6	C6	C6	C6	C6	C6	
Workshop tools	C7	C7	C7	C7	C7	C7	C7	



## Precautions

### Danger – Exhaust gases

To ensure adequate ventilation, always open garage doors fully before starting the car in a garage, or any confined space.

The exhaust gases contain carbon monoxide (CO), which is odourless and invisible, but very poisonous.

Operating the air conditioning system increases the danger of these gases entering the car.

### General precautions

Before commencing work on the electrical system it is recommended that either the battery master switch be turned to the OFF position or that the battery is disconnected.

If the master switch has to be left in the ON position or if the battery is left connected, the gear range selector lever **must** be placed in the park position and the gearchange isolating fuse (fuse A6) removed from fuseboard F2 at the main fuseboard. Then remove the ignition key.

Never disconnect the battery or switch off the battery master switch when the engine is running.

Always ensure correct polarity when making cable connections.

It is recommended that when carrying out tests on the car wiring, a good quality multi-meter is used.

Never use generator type meters.

Do not use a test lamp on circuitry that contains electronic components, such as the air conditioning system.

When working on or in the vicinity of the air conditioning micro-processor, anti-static precautions, in particular the wearing of an anti-static wristband connected to a good earth, must be observed.

### Special precautions

The refrigerant used in the air conditioning system is dichlorodifluoromethane (Refrigerant 12). It is supplied to the service network in disposable containers or metal drums.

When correctly handled the refrigerant is perfectly safe, however, incorrect handling could result in injury or accident.

The following precautions must always be observed.

1. Do not smoke in the vicinity of refrigerant or a refrigeration system.
2. Always wear safety glasses when working on a refrigeration system.
3. Store refrigerant containers upright and away from direct sunlight.
4. When transporting refrigerant, ensure that the containers are secured, remain upright and away from direct sunlight.
5. Ensure that caps are fitted to drums not in use.

6. Refrigerant containers must not be overfilled, increased pressure could cause an explosion.

7. To heat the drum when charging a system, immerse in warm water at a maximum temperature of 51°C (124°F).

Never place the drum on a hot surface or attempt to heat the drum by means of a blowlamp, etc.

8. Do not discharge refrigerant in confined spaces or near to exposed flames. Contact with exposed flames can produce a toxic gas.

Always keep refrigerant clear of engine air intakes.

9. Excessive heat applied to any part of the refrigeration system will create high pressures within the system. Therefore, welding, soldering, or brazing should not be carried out on the system, or to any adjacent part of the car.

### First aid – Refrigerant burns

If the skin comes into contact with refrigerant, it should be bathed with clean cold water and medical attention sought immediately. Do not apply localized heat, hot dressings, etc.

If an eye should become affected by refrigerant, it must be immediately washed with clean cold water. The eye must not be rubbed as this will aggravate the injury.

After administering this emergency treatment a doctor should be consulted as soon as possible.



## Electrical test and fault diagnosis

Contents	Pages				Bentley			
	Rolls-Royce		Corniche	Corniche II	Eight	Mulsanne Turbo R	Continental	
	Silver Spirit	Silver Spur						
Introduction	C4-3	C4-3	C4-3	C4-3	C4-3	C4-3	C4-3	C4-3
Test procedures using test box RH 9884	C4-3	C4-3	-	-	C4-3	C4-3	C4-3	-
Fan control circuits								
Wiring diagram and component location	C4-6	C4-6	-	-	C4-6	C4-6	C4-6	-
Temperature control circuits								
Wiring diagram and component location	C4-8	C4-8	-	-	C4-8	C4-8	C4-8	-
Test procedures using a multi-meter	C4-10	C4-10	-	-	C4-10	C4-10	C4-10	-
Air conditioning micro-processor board	C4-13	C4-13	C4-13	C4-13	C4-13	C4-13	C4-13	C4-13



## Electrical test and fault diagnosis

### Introduction

If an electrical fault is suspected on the air conditioning system it will be necessary to determine whether the fault is in the wiring of the air conditioning system or on the micro-processor board.

If it is determined that the fault is on the micro-processor board, the board must be replaced as it is a non-serviceable item.

The wiring can be tested using the air conditioning test box RH 9884. Alternatively, test the wiring using a good quality multi-meter capable of measuring continuity, resistance, and direct current voltage.

If using the test box it is recommended that the test procedures be carried out in full, noting any malfunction. On completion of the test box procedures, correct any malfunction by selecting the appropriate sub-heading under Test procedures using a multi-meter. Carry out that particular procedure before retesting the system with the test box.

When correcting a malfunction or carrying out the test procedures using a multi-meter, identification of cable routes and connections, also components, can be made using the wiring diagrams and component locations contained within this section.

When working on or in the vicinity of the air conditioning micro-processor, anti-static precautions, in particular, the wearing of an anti-static wristband connected to a good earth, must be observed.

To avoid damage to the mating surfaces of plug or socket connections it is recommended that meter probes, etc., are applied from the rear, cable entry side. It may be necessary to release the locking bar of the plug or socket to achieve this.

Where it is necessary to start the car engine, all normal workshop safety precautions must be observed.

Before commencing the test procedures always ensure that the battery is in a fully charged condition.

### Test procedures using test box RH 9884

#### Initial procedure

1. Remove fuse A1 at fuseboard F1.
2. Disconnect both the left-hand and right-hand 18-way plugs at the micro-processor. To avoid damage to the board it will be necessary to hold the opposite end of the board when removing a plug.
3. With all switches on the test box in the up position, connect the test box as follows.
  - a. Connect the lead from the test box marked LEFT to the left-hand 18-way plug from the micro-processor.
  - b. Connect the lead from the test box marked RIGHT to the right-hand 18-way plug from the micro-processor.

- c. Ensure that the termination on the single red cable from the test box is insulated and free from any earth potential.
- d. Connect the single purple cable from the test box to a known, fused, 12 volts positive supply.
4. Select ON position at the POWER switch on the test box noting that.
  - a. Dependent on the position of the air conditioning function switch on the facia, the corresponding lamp on the test box will be illuminated.
  - b. When testing with a cold engine [engine coolant temperature below 44°C (111°F)] the 44°C lamp on the test box will be illuminated.
  - c. The ALT (alternator) lamp on the test box will only be illuminated when the engine is running.

#### Air conditioning function switch – To test

1. Select OFF position at the air conditioning function switch on the facia. The OFF lamp at the test box should illuminate.
2. Rotate the function switch from OFF through each position to the  (defrost) position. At each switch position the corresponding lamp on the test box should illuminate.

#### Fans control circuit – To test

1. Move the left-hand FAN CONTROL switch on the test box to the down (ON) position. The fans should operate at minimum speed.
2. From left to right select the down position on the four remaining FAN CONTROL switches noting that as each switch is operated the speed of the fans increases.
3. Switch OFF the left-hand FAN CONTROL switch. Both fans should stop.

#### Mode change actuator – To test

1. Move the MODE switch on the test box to the down position. The mode change actuator should operate, directing air to the facia position.
2. Move the MODE switch on the test box to the SCREEN (up) position. The mode change actuator should operate, directing air to the screen position.
3. Ensure that the mode change flap seals effectively, especially in the screen position.

#### Left-hand recirculation actuator – To test

1. Move the L.H. switch on the test box to the down position. The left-hand recirculation actuator should operate, directing air to the fresh air position.
2. Move the L.H. switch on the test box to the RECIRC (up) position. The actuator should operate, directing air to the recirculation position.
3. Ensure that the flap seals effectively, especially in the recirculation position.

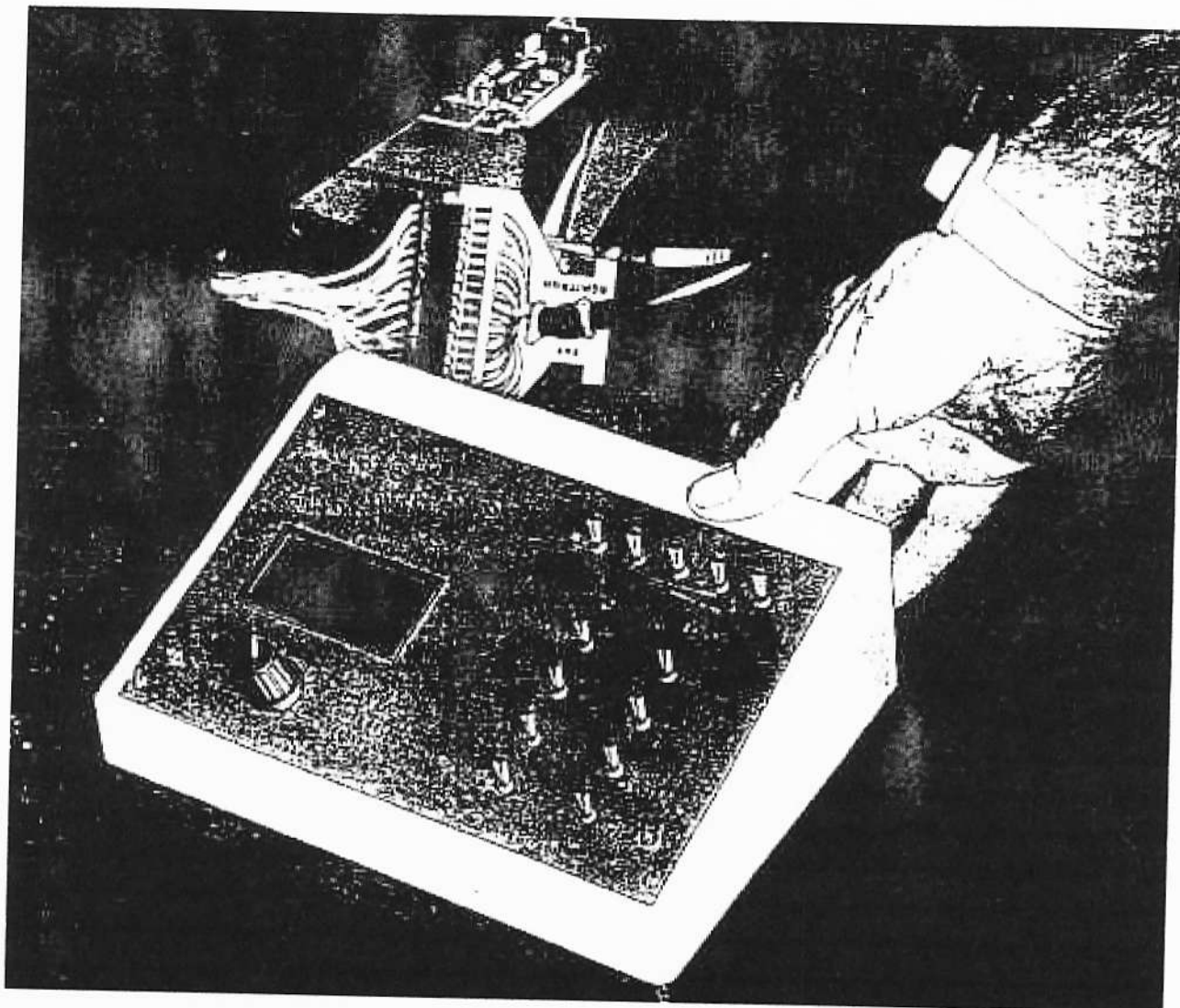

Fig. C4-1 Air conditioning system test box RH 9884

**Right-hand recirculation actuator – To test**

1. Move the R.H. switch on the test box to the down position. The right-hand recirculation actuator should operate, directing air to the fresh air position.
2. Move the R.H. switch on the test box to the RECIRC (up) position. The actuator should operate, directing air to the recirculation position.
3. Ensure that the flap seals effectively, especially in the recirculation position.

**Lower quantity actuator – To test**

1. Move the LOWER FLAP switch on the test box to the down position. The lower quantity actuator should operate, directing air to the lower outlets.
2. Move the LOWER FLAP switch on the test box to the SHUT (up) position. The lower quantity actuator should operate, closing off air from the lower outlets.
3. Ensure that the flap seals effectively, especially in the closed position.

**Air conditioning temperature sensors – To test**

1. Rotate the selector switch on the test box to the AMBIENT position. Read off the voltage.  
Compare the voltage reading with the Temperature sensor voltage response graph and table given in figure C4-2. If the reading is within a  $\pm 5\%$  tolerance the sensor is functioning correctly.
2. Repeat procedure 1 with the selector switch in the LOWER position.
3. Repeat procedure 1 with the selector switch in the TOP ROLL (solar) position.
4. Repeat procedure 1 with the selector switch in the UPPER position.

**Screen-facia/recirc switch – To test**

1. Press and hold the SCREEN-FACIA/RECIRC switch on the facia to the SCREEN/FACIA position. The SCREEN FACIA lamp on the test box should illuminate.

It should be noted that when carrying out this operation on certain 1987 model year cars the RECIRC lamp on the test box also illuminates but at a slightly lower intensity. If illumination of the lamp does occur, before continuing with the test procedure, the pink cables connected between the SCREEN-FACIA/RECIRC switch and the inner switch panel plug and socket 6-way must be disconnected and permanently removed.

2. Select the RECIRC position at the SCREEN-FACIA/RECIRC switch. The RECIRC lamp on the test box should illuminate.
3. Return the SCREEN-FACIA/RECIRC switch to the central position. The RECIRC lamp will be restored to its original condition, i.e. not necessarily extinguished.

#### Temperature selector controls test procedure

1. Rotate the selector switch on the test box to the REFERENCE position. Read off the voltage (approximately 2.5 volts).
2. Rotate the upper temperature selector on the facia to the mid-position and the selector switch on the test box to the UPPER SEL position. Read off the voltage. This output voltage should be within  $\pm 0.5$  volt of the reference voltage.
3. Rotate the lower temperature selector on the facia to the mid-position and the selector switch on the test box to the LOWER SEL position. Read off the voltage. This output voltage should be within  $\pm 0.5$  volt of the reference voltage.

#### Rear window demister and mirror heaters, compressor clutch, and water tap test procedure

1. Rotate the selector switch on the test box to the BAT. VOLTS position.
2. Move the H.R.W. switch to the down position. The voltage reading on the test box should decrease.
3. Move the H.R.W. switch to the up (off) position.
4. Move the COMP. CLUTCH switch to the down position. The compressor clutch in the engine compartment should be heard to operate.
5. Move the COMP. CLUTCH switch to the up (off) position.
6. Move the WATER TAP switch to the down position. The water tap situated in the engine compartment should operate.
7. Move the WATER TAP switch to the up (off) position.

**Air conditioning coolant temperature switch – To test**  
This test must be carried out with a cold engine [i.e. engine coolant temperature below 44°C (111°F)].

1. The 44°C lamp on the test box will be illuminated.
2. Disconnect the coolant temperature switch on the thermostat housing. The 44°C lamp on the test box should extinguish.
3. Re-connect the coolant temperature switch.

#### Test procedures conclusion

1. Having verified the car wiring.
  - a. Disconnect the 12 volts positive supply to the test box.

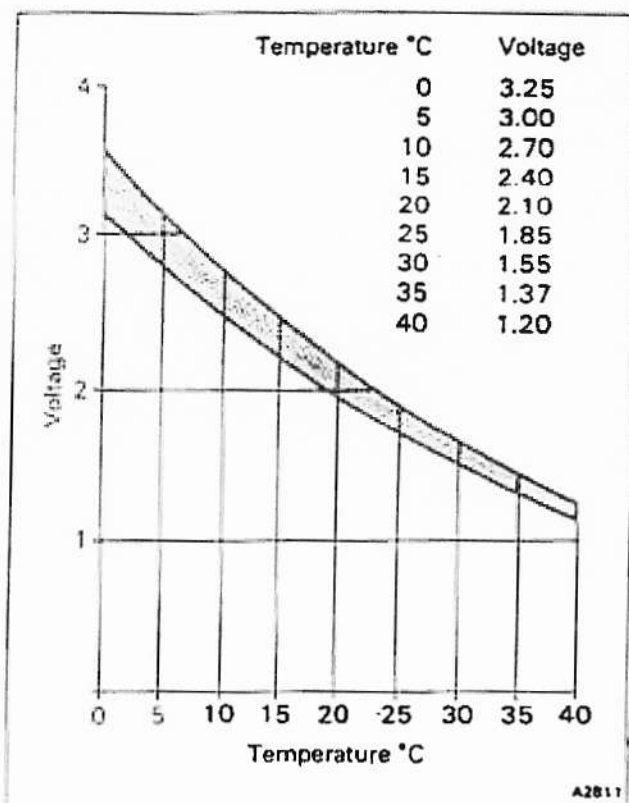

Fig. C4-2 Temperature sensor voltage response graph and table

- b. Disconnect the test box.
  - c. Re-connect the 18-way plugs to the micro-processor.
  - d. Replace fuse A1 at fuseboard F1.
2. Test the air conditioning system. If a malfunction is still apparent carry out the Micro-processor initializing procedure given under the heading Air conditioning micro-processor board.
 

If correct operation of the upper and lower blend flap actuators is verified by the initializing procedure the fault will be on the micro-processor board. Therefore, fit a new board.

If the correct operation of the upper and lower blend flap actuators cannot be verified by the initializing procedure, first substitute the actuator(s) to determine whether the fault is with the actuator(s) or on the micro-processor board. Renew as necessary.



## Fan control circuit

Wiring diagram and component location

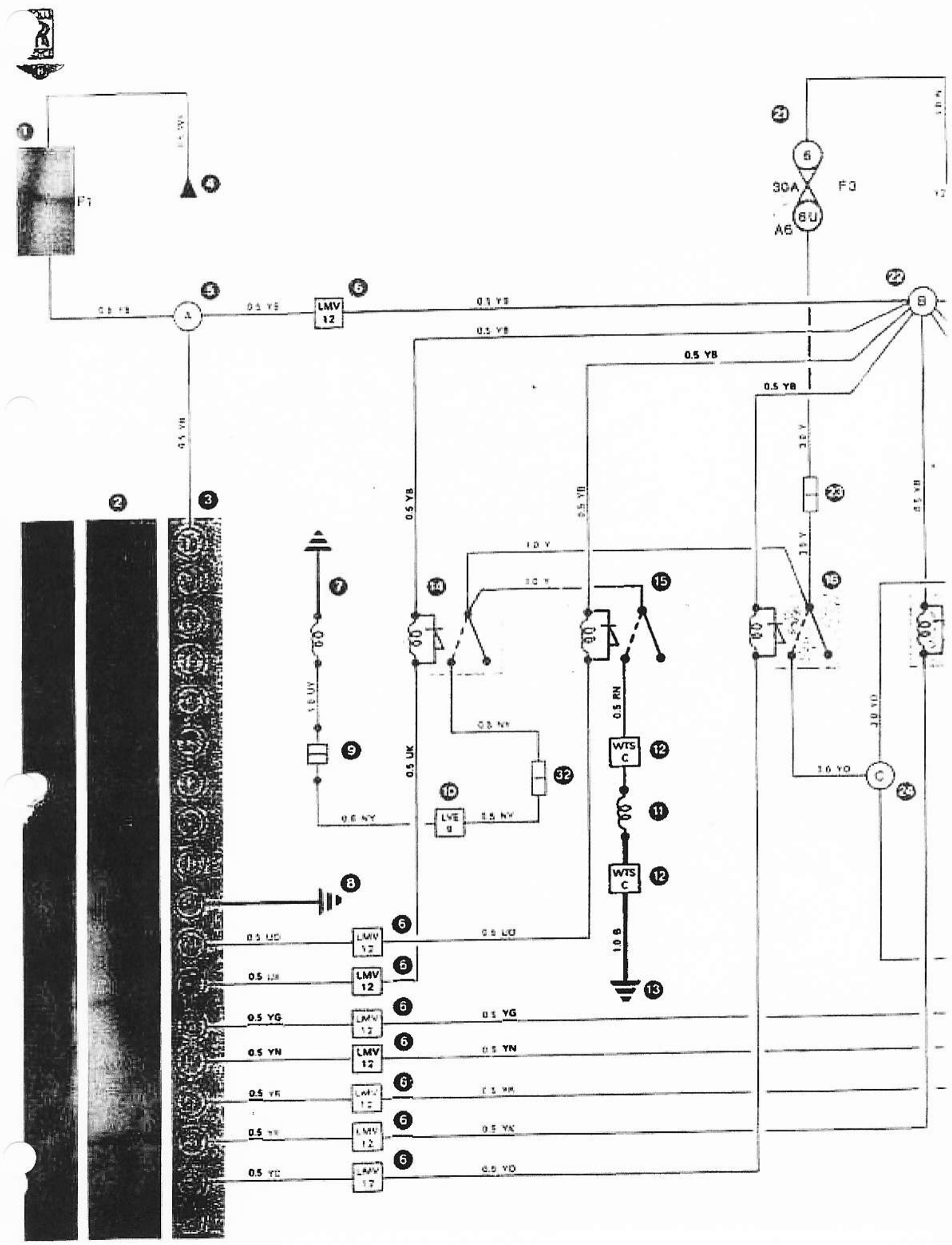

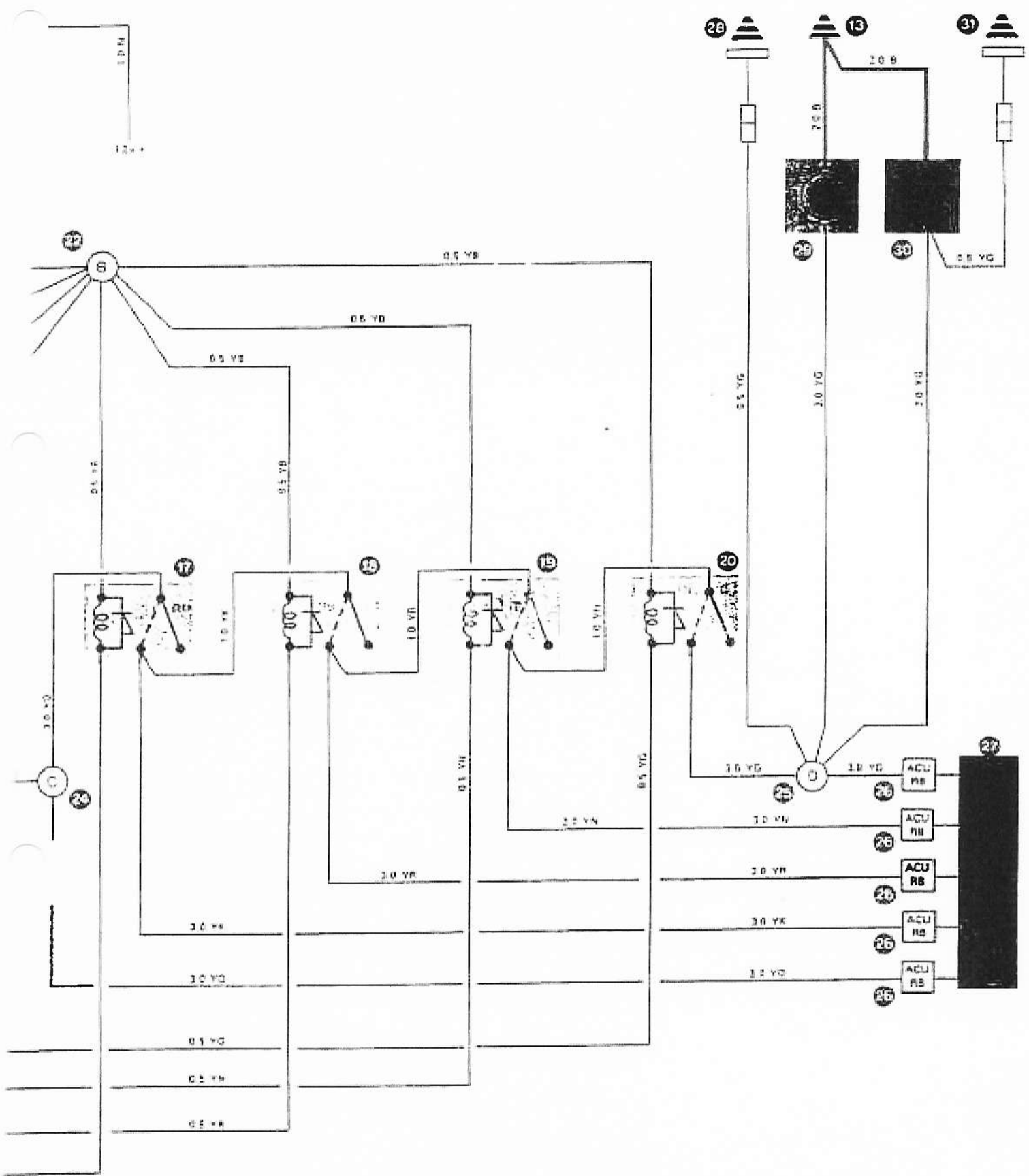

- 1 Fuseboard F1, fuse A1, 10 Amp
- 2 Air conditioning unit micro-processor
- 3 Air conditioning unit micro-processor plug 18-way - right-hand
- 4 12 volts positive supply when engine is running
- 5 Splice A

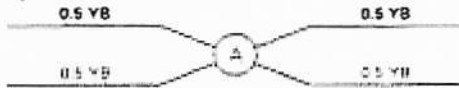

- 6 Left-hand main to valance loom plug and socket 12-way
- 7 Compressor clutch solenoid
- 8 Transmission tunnel earth point
- 9 Compressor ambient thermostat
- 10 Left-hand valance to engine loom plug and socket 9-way
- 11 Water tap solenoid
- 12 Water tap solenoid connection
- 13 Front valance earth point
- 14 Compressor clutch relay
- 15 Water tap relay
- 16 Fans control relay
- 17 Fan speed relay 4
- 18 Fan speed relay 3
- 19 Fan speed relay 2
- 20 Fan speed relay 1
- 21 Fuseboard F3, fuse A6, 30 Amp
- 22 Splice B

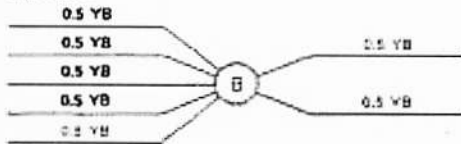

- 23 Left-hand main to valance loom connection
- 24 Splice C

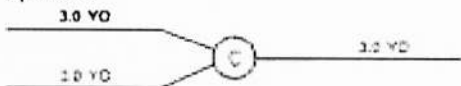

- 25 Splice D



- 26 Air conditioning unit resistor block plug and socket
- 27 Air conditioning unit resistor block
- 28 Air conditioning fan suppressor - left-hand
- 29 Air conditioning fan - left-hand
- 30 Air conditioning fan - right-hand
- 31 Air conditioning fan suppressor - right-hand
- 32 Air conditioning loom to left-hand valance loom connection

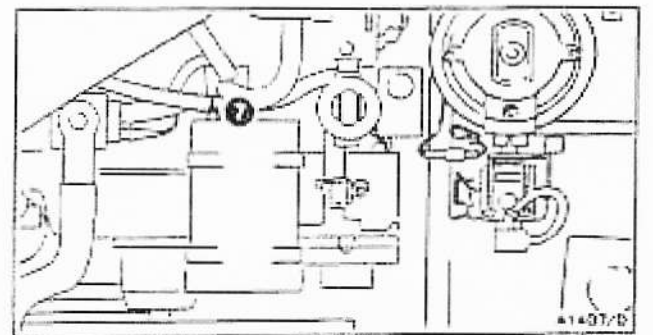
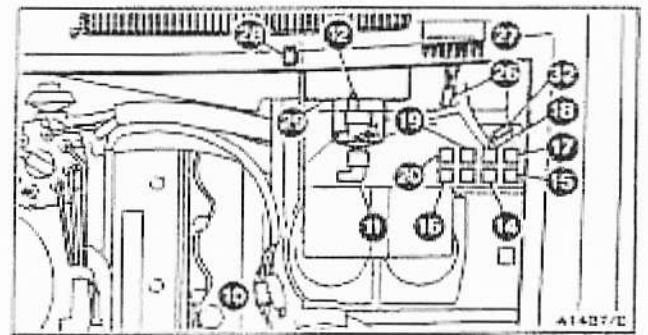
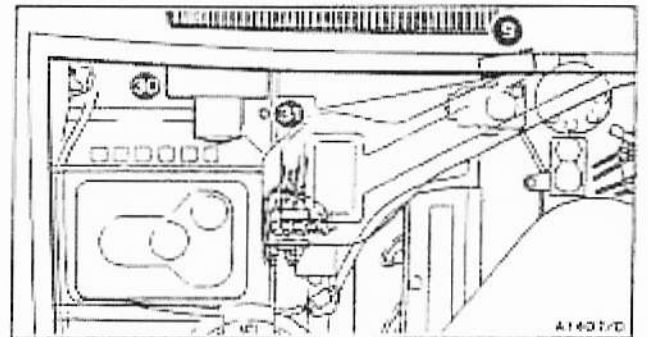
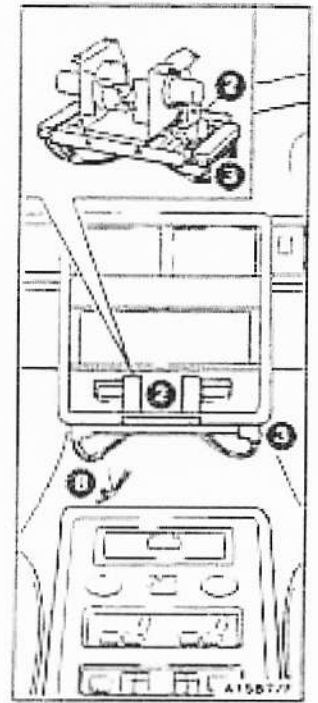
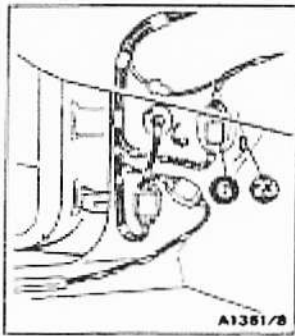
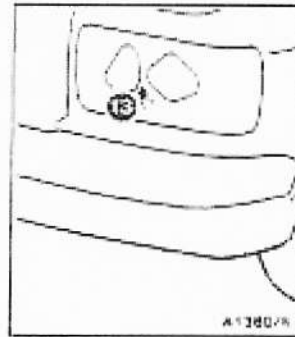



# Temperature control circuit

Wiring diagram







## Temperature control circuit

Component location

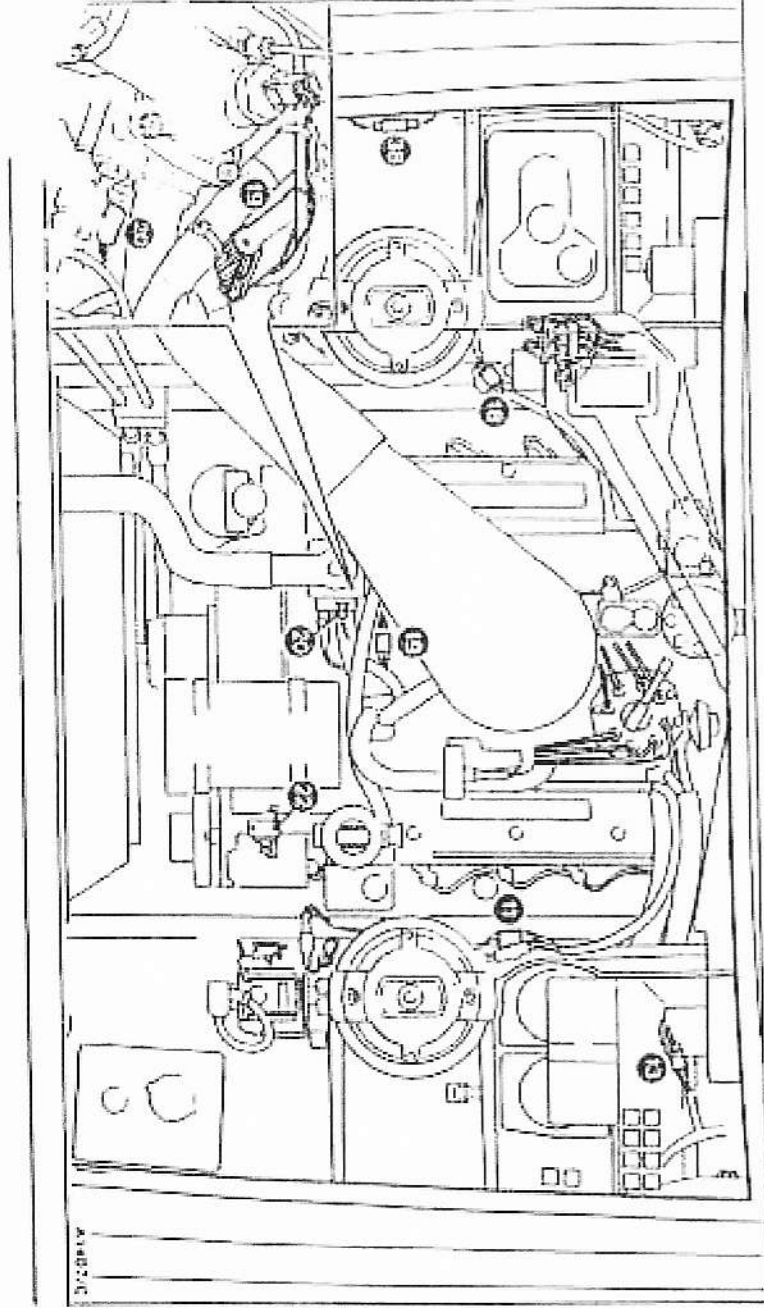

AMERICAN

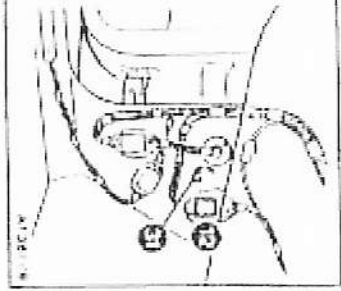

AMERICAN

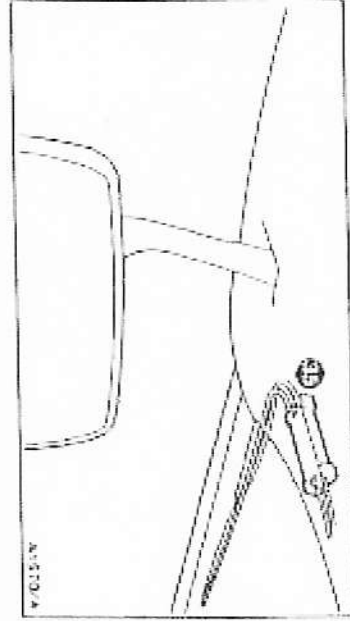

AMERICAN

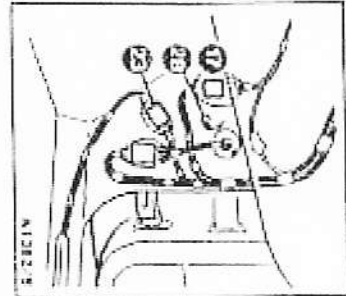

AMERICAN

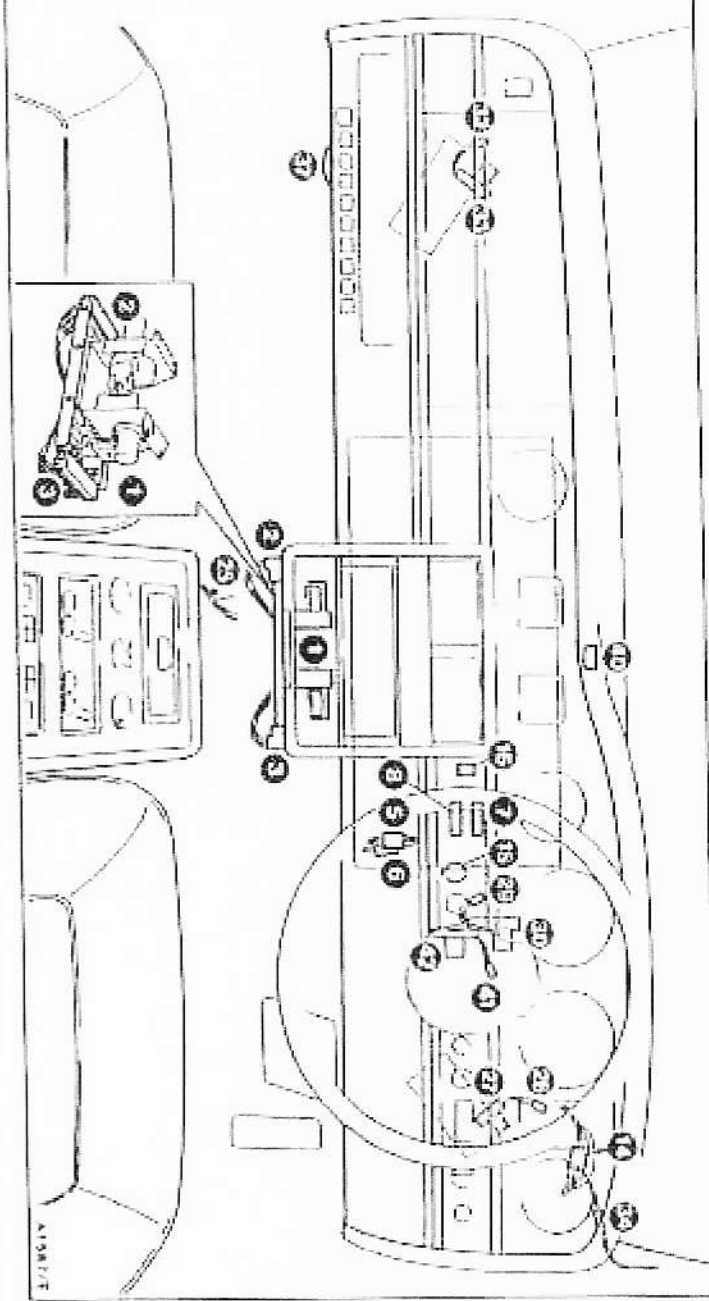

AMERICAN



- 1 Air conditioning unit micro-processor
- 2 Air conditioning unit micro-processor plug 18-way – left-hand
- 3 Air conditioning unit micro-processor plug 18-way – right-hand
- 4 Splice A

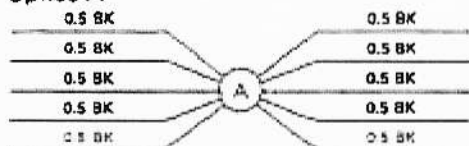

- 5 Inner switch panel plug and socket 6-way
- 6 Inner switch panel plug and socket 12-way
- 7 Upper temperature selector
- 8 Lower temperature selector
- 9 Splice B

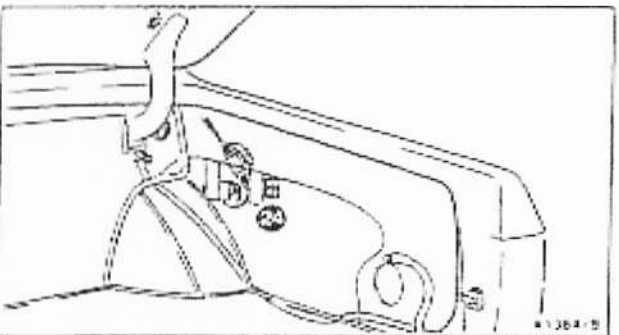
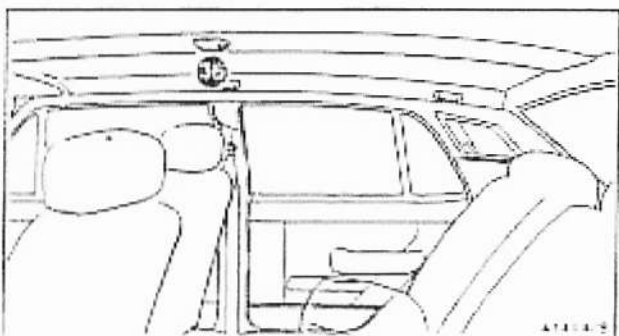
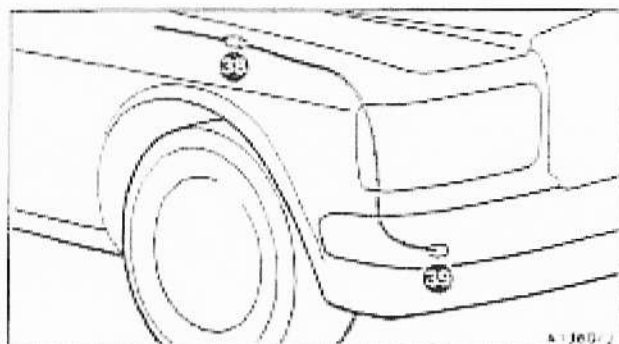
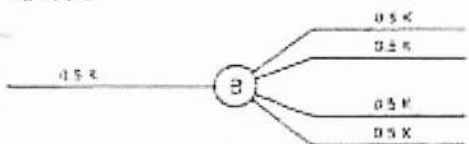

- 10 Monitor supply from alternator (14 volts positive with engine running) to allow rear window and door mirror demisting
- 11 Left-hand valve to engine loom plug and socket 9-way
- 12 Left-hand main to valve loom plug and socket 12-way
- 13 Anti-lock braking system plug and socket 5-way
- 14 Switchbox plug and socket 18-way
- 15 Air conditioning control switch
- 16 Screen-facia/recirc switch
- 17 Right-hand main to valve loom plug and socket 12-way
- 18 Right-hand valve to engine loom plug and socket 9-way

- 19 Engine thermostat loom plug and socket 12-way
- 20 Coolant temperature switch

- 21 Splice C

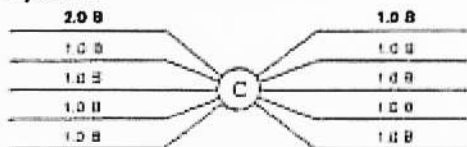

- 22 Engine earth point
- 23 Right-hand 'A' post main to body loom plug and socket 12-way
- 24 Rear window demister relay – for details of the rear window demister and mirror heaters circuit refer to TSD 4701 Workshop Manual – Electrical, Section 16
- 25 Transmission tunnel earth point
- 26 Right-hand recirculation actuator plug and socket
- 27 Right-hand recirculation actuator
- 28 Right-hand 'A' post earth point
- 29 Mode change actuator plug and socket
- 30 Mode change actuator
- 31 Left-hand 'A' post earth point

- 32 Left-hand recirculation actuator plug and socket
- 33 Left-hand recirculation actuator
- 34 Right-hand main to cantrail loom plug and socket 6-way
- 35 Right-hand cantrail to sensor loom plug and socket 2-way
- 36 Cantrail sensor
- 37 Knee roll sensor
- 38 Air conditioning unit ambient sensor plug and socket
- 39 Ambient sensor
- 40 Top roll (solar) sensor
- 41 Lower quantity actuator plug and socket
- 42 Lower quantity actuator

— — — — — Denotes alternative cable route on Turbocharged cars

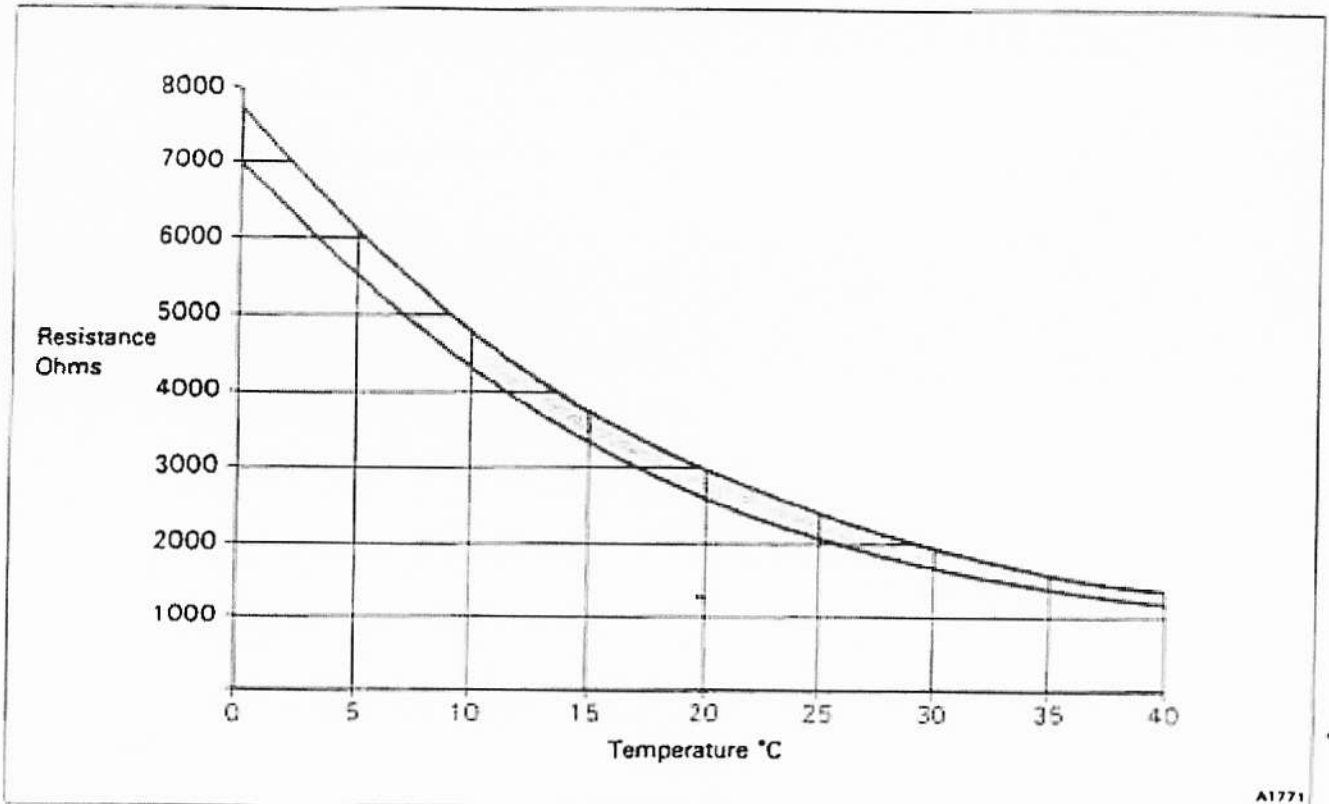

Fig. C4-3 Temperature sensor resistance graph

**Lower quantity actuator – To test**

Test procedure carried out at the right-hand 18-way plug.

1. Apply a known 12 volts positive supply to the green/slate cable at pin 12. The actuator should move the flap to the closed position.

Should the actuator fail to move.

- a. Ensure that there is a good earth connection to the actuator.
  - b. Disconnect the 12 volts positive supply before checking the continuity of the green/slate cable to the actuator.
2. Apply a known 12 volts positive supply to the orange/slate cable at pin 13. The actuator should move the flap to the open position.

Should the actuator fail to move, disconnect the 12 volts positive supply before checking the continuity of the orange/slate cable to the actuator.

3. If no fault is found renew the actuator.

**Air conditioning temperature sensors – To test**

Test procedure carried out at the right-hand 18-way plug.

1. Disconnect the battery.
2. With the multi-meter set to ohms range.
  - a. Measure the resistance of each sensor between its connection at the plug (see item f) and a known earth point.
  - b. Compare the resistance measurement with the temperature/resistance graph shown in figure C4-3

c. If the resistance falls to within  $\pm 5\%$  of the graph reading, the sensor is operating correctly.

d. If the graph reading is significantly outside the  $\pm 5\%$  tolerance, renew the sensor.

e. If a measurement cannot be obtained, check the continuity of the sensor wiring.

f. Sensor connections.

Red/orange cable at pin 14 – Solar (top roll) sensor.

Red/yellow cable at pin 15 – Ambient sensor.

Red/green cable at pin 16 – Lower air (knee roll) sensor.

Red/blue cable at pin 17 – Upper air (roof) sensor.

3. Re-connect the battery.

**Screen-facia/recirc switch – To test**

Test procedure carried out at the left-hand 18-way plug.

1. Ensure the continuity of the pink/yellow cable at pin 2 to the black/pink cable at pin 14 when the SCREEN-FACIA/RECIRC switch is in the SCREEN-FACIA position.

2. Ensure the continuity of the pink/green cable at pin 3 to the black/pink cable at pin 14 when the SCREEN-FACIA/RECIRC switch is in the RECIRC position.

**Temperature selector controls test procedure**

Test procedure carried out at the left-hand 18-way plug.

1. Disconnect the battery.

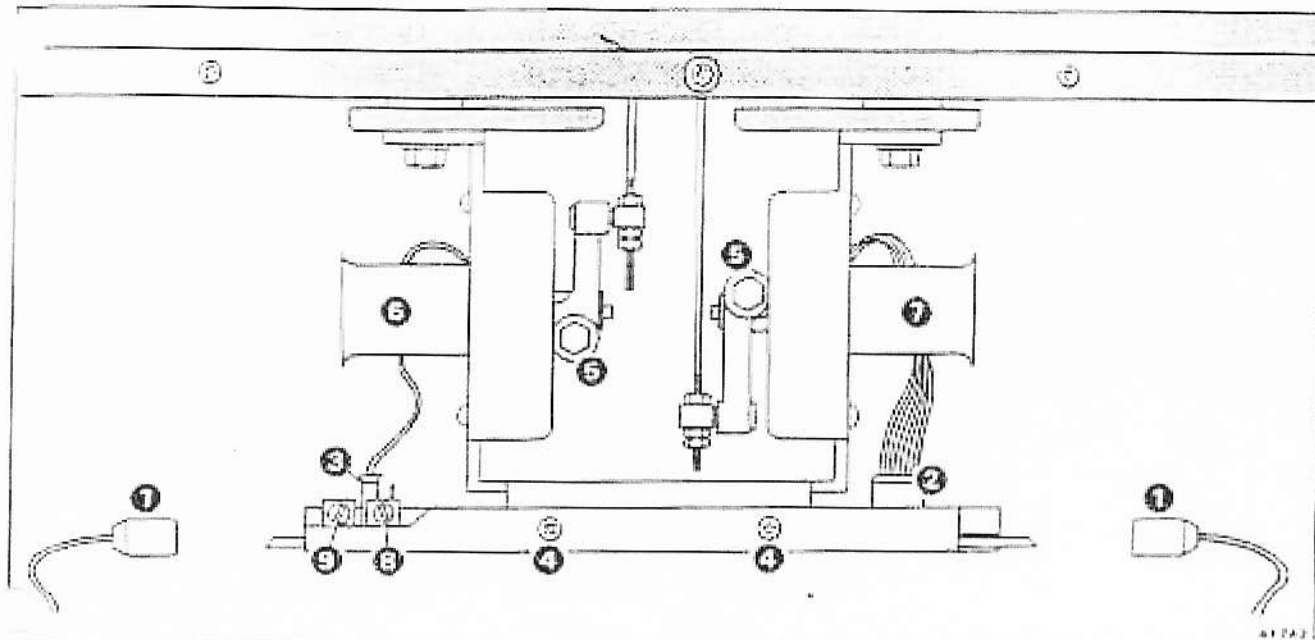

Fig. C4-4 Micro-processor and blend flap actuators assembly

2. With the multi-meter set to ohms range, measure the resistance from the pink cable at pin 13 to the black/pink cable at pin 14. The reading should be 500Ω.

If a reading of 1000Ω is recorded, one of the selector potentiometers is open circuit and must be replaced.

3. Rotate the lower temperature selector to the mid-position. Measure the resistance between the pink/red cable at pin 11 and the black/pink cable at pin 14. The reading should be 500Ω.

Rotate the lower temperature selector ensuring that a lower reading is measured as the red section is exposed, and a higher resistance is measured as the blue section is exposed.

Rotate the upper temperature selector to the mid-position. Measure the resistance between the pink/brown cable at pin 11 and the black/pink cable at pin 14. The reading should be 500Ω.

Rotate the upper temperature selector ensuring that a lower resistance is measured as the red section is exposed, and a higher resistance is measured as the blue section is exposed.

5. Re-connect the battery.

**Rear window demister and mirror heaters, compressor clutch, and water tap test procedure**  
Test procedure carried out at the right-hand 18-way plug.

1. Remove fuse A1 at fuseboard F1.
2. Apply a known 12 volts positive supply to the yellow/black cable connection at terminal 1 of the fuseboard.
3. Apply a known earth to the following cables ensuring in each case that the appropriate relay energizes.

Orange/brown cable at pin 1 – rear window demister relay.

Blue/pink cable at pin 7 – compressor relay.

Blue/orange cable at pin 8 – water tap relay.

4. Should a relay not energize, first replace the relay and repeat the appropriate test.

If the relay still does not energize, disconnect the 12 volts positive supply before checking the continuity of the yellow/black cable from the fuse to the relay. If necessary, check the continuity of the appropriate cable to the other side of the relay coil (from the 18-way plug).

5. If all relays energize in procedure 3, and a fault is still suspected, refer to the appropriate wiring diagram for further details.

**Note** The wiring diagram for the compressor clutch and the water tap are contained within this section. However, the wiring diagram for the Rear window demister and mirror heaters circuit is contained in TSD 4701 Workshop Manual – Electrical, Section 16.

**Air conditioning coolant temperature switch – To test**  
This test must be carried out with a cold engine [i.e. engine coolant temperature below 44°C (111°F)].

1. Check the continuity of the red/slate cable at pin 1 of the left-hand 18-way plug to a known earth point.
2. Disconnect the air conditioning coolant temperature switch and ensure that the red/slate cable now reads open circuit. Re-connect the switch.

**Test procedures conclusion**

1. Having verified the car wiring.
  - a. Ensure that all connections are remade.
  - b. If a fault has been found, retest the air conditioning system.

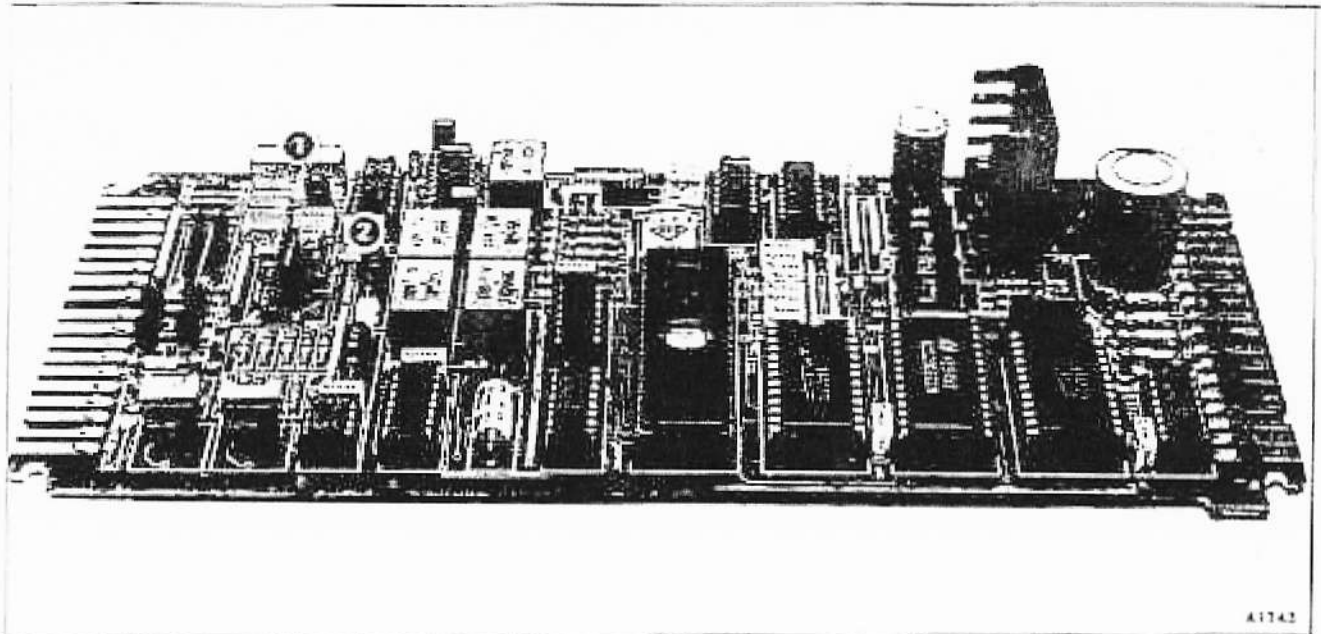

Fig. C4-5 Air conditioning micro-processor board

2. If no fault has been found and the air conditioning system circuitry is still faulty, replace the micro-processor board.

#### Air conditioning micro-processor board Handling precautions

The micro-processor board and connectors are durable if handled correctly. However, they are vulnerable to stray voltages, wrong polarity and especially static electricity. Therefore anti-static precautions, in particular the wearing of an anti-static wristband connected to a good earth, must be observed at all times.

The board is particularly vulnerable before the edge connectors are fitted (i.e. before it is earthed). Handling should therefore be kept to a minimum.

Boards must be stored in anti-static containers and kept dry and free from grease.

#### Micro-processor board – To remove (see fig. C4-4)

1. Remove fuse A1 at fuseboard F1.
2. To avoid damage when disconnecting or re-connecting a micro-processor board 18-way plug, it will be necessary to hold the opposite end of the board.

Disconnect both the left-hand and right-hand 18-way plugs from the micro-processor board (see item 1).

3. Disconnect the upper and lower blend flap actuator plugs from the micro-processor board (see items 2 and 3).
4. Remove the two setscrews securing the micro-processor board front retaining channel (see item 4). Remove the channel.
5. Lower the front edge of the micro-processor board and carefully withdraw.

#### Micro-processor board – To fit

Reverse Operations 2 to 5 inclusive of Micro-processor board – To remove. Then, carry out the Micro-processor initializing procedure.

#### Micro-processor initializing procedure (refer to figs. C4-4 and C4-5).

To carry out this procedure it may be necessary on some cars to remove the centre console. Refer to Chapter 5 of this manual for details.

1. Ensure that fuse A1 at fuseboard F1 is removed.
2. Ensure that the SCREEN-FACIA/RECIRC switch is set to the mid position.
3. Fit the micro-processor board test pins link RH 9884 DET 2 or bridge the test pins (see fig. C4-5 item 2).
4. Slacken the actuator arm securing bolts at the upper and lower blend flap actuators (see fig. C4-4 item 5).
5. Apply a known, fused, 12 volts positive supply to the yellow/black cable connection at the fuseboard.  
If using test box RH 9884 with the purple cable connected to a 12 volts positive supply, the red cable from the test box can be connected to the yellow/black cable at the fuseboard. It should be noted that the large cables marked LEFT and RIGHT from the test box are not connected during this procedure.
6. Select OFF position at the air conditioning function switch on the facia. The lower blend flap actuator (see fig. C4-4 item 6) will operate and continue to operate during procedure 7.
7. Rotate the lower blend flap potentiometer (see fig. C4-4 item 8) throughout the full range of its travel, noting the portion of travel for which the LED (light emitting diode) on the micro-processor board (see fig. C4-5 item 1) illuminates.



Adjust the potentiometer to the centre of the illuminated portion of travel.

8. Select the ☰ (defrost) position at the air conditioning switch on the fascia. The upper blend flap actuator will operate and continue to operate during procedure 9.

9. Rotate the upper blend flap potentiometer (see fig. C4-4 item 9) throughout the full range of its travel, noting the portion of travel for which the LED on the micro-processor board illuminates.

Adjust the potentiometer to the centre of the illuminated portion of travel.

10. Remove the test pins link RH 9884 DET 2 or remove the bridge from the test pins.

11. Tighten the actuator arm securing bolts at the upper and lower blend flap actuators (see fig. C4-4 item 5).

12. Disconnect the 12 volts positive supply from fuse A1 yellow/black cable connection.

13. Replace fuse A1 at fuseboard F1.

14. Test the air conditioning system.