



Figure B4-36

'On-board' fault diagnosis codings

'On-board' diagnostic check

This procedure should be followed if

- a) The 'Check Engine' warning panel situated on the fascia, illuminates during normal engine operation.
- b) A routine 'on-board' diagnostic check is required.

Note There are four possible faults in the K-Motronic engine management system that are not externally registered by the illumination of the 'Check Engine' warning panel. These faults will however, be revealed by a blink code during an 'on-board' diagnostic check.

Procedure

Initiate an 'on-board' diagnostic check to reveal any of the listed fault codes that have been stored within the K-Motronic ECU buffer RAM (random-access memory).

1. Ensure that the usual workshop precautions are carried out.
2. Turn the ignition key to the RUN position on the switchbox, so that the 'Check Engine' warning panel illuminates (see illustration A).
3. Depress the 'on-board' diagnostic button (see illustration B) for a minimum of 4 seconds and then release.
4. Monitor the blink code on the 'Check Engine' warning panel, after the initial period of 2.5 seconds lamp on and 2.5 seconds lamp off. Refer to illustration C for an example of the initial period of 'Check Engine' warning panel operation, followed by the blink code 4.4.3.1.
5. Once a blink code has been initiated, it will keep repeating the information (with initiation periods identifying blink code commencement), until the 'on-board' diagnostic button is depressed for another 4 seconds period.

This procedure must be repeated until all stored blink codes have been extracted from the K-Motronic ECU buffer RAM.

6. If there are no more fault codes stored, the condition is identified by the unique code 1.1.1.1. Warning panel on/off periods for this code are of 2.5 seconds duration.
7. To reset the buffer RAM following fault extraction and/or rectification, isolate the vehicle battery using the master switch located in the vehicle luggage compartment (see illustration D). To ensure complete K-Motronic ECU buffer RAM reset, the battery should be switched off for at least 4 seconds.
8. If there are no faults stored, then the blink code 4.4.4.4. will register on the 'Check Engine' fascia warning panel.

Fault codes

Blink code	'Check Engine' panel illuminated	Fault description
2.3.1.2.	Yes	Coolant temperature sensor operating range
2.2.3.2.	Yes	Incorrect air flow signal
2.1.2.1.	No	Idle switch fault. Idle speed not recognised
2.1.2.3.	Yes	Full load switch fault Full load control maps not set
2.1.1.3.	Yes	Engine speed sensor and/or the ECU defective. Air flow mechanism or fuel distributor stuck
4.4.3.1.	No	Idle speed actuator control or short circuit
2.3.4.2.	Yes	Lambda sensor and/or control
2.3.4.1.	Yes	Lambda control outside operating range
2.3.4.3.	No	Basic idle mixture strength mixture control unit set
2.3.4.4.	No	Basic idle mixture strength mixture control unit set
4.3.1.2.	Yes	Engine reference sensor connection to the ECU

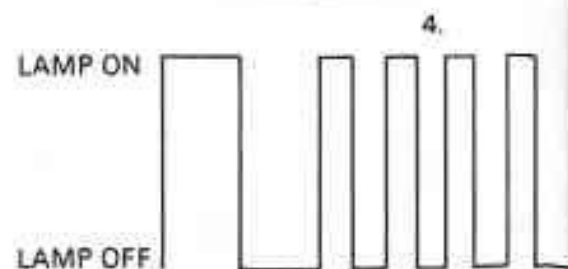
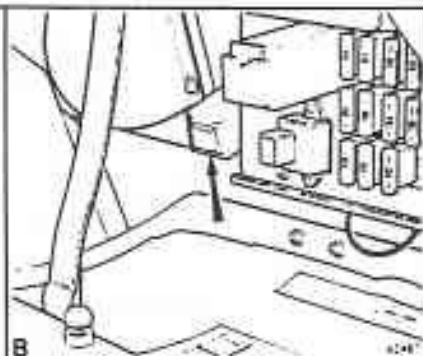
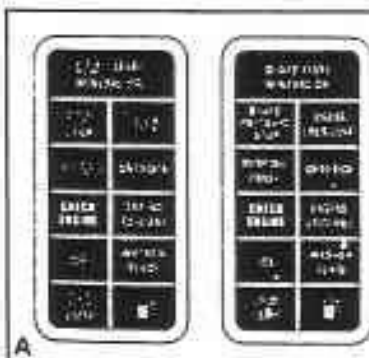

sensor output outside	<p>System method of recognition</p> <p>Coolant temperatures less than -46°C (-50.8°F) or more than $+186^{\circ}\text{C}$ ($+366.8^{\circ}\text{F}$)</p> <p>Volumetric air flow rate outside pressure upper and lower threshold limits (i.e. less than $5\text{m}^3/\text{hr}$ or more than $1200\text{m}^3/\text{hr}$)</p>	<p>Limp home facility</p> <p>K-Motronic ECU provides EHA with mA compensation equivalent to $+80^{\circ}\text{C}$ (176°F) coolant temperature for all operational modes other than starting which is set to $+20^{\circ}\text{C}$ (68°F)</p> <p>Ignition and fuelling switched to full load map</p>
control maps not	<p>Idle switch closed. Air flow greater than $166\text{m}^3/\text{hr}$ with switch closed for more than 0.3 seconds</p>	<p>Ignition and fuelling switched to part load map</p>
not recognised	<p>Full load switch closed but ECU recognises part load engine operation for more than 0.3 seconds</p>	<p>Ignition and fuelling switched to part load map</p>
and/or connection to sensor plate injector plunger	<p>Ignition switched on, volumetric air flow rate more than $5\text{m}^3/\text{hr}$ but no engine speed signal</p>	<p>None</p>
injecting plug open	<p>End stage within K-Motronic ECU</p>	<p>Engine idle speed may drift from 580 ± 20 rev/min. Normal engine operation under all conditions except idle mode</p>
connection failure	<p>End stage within K-Motronic ECU</p>	<p>Resort to 'open loop' engine operation</p>
threshold limits	<p>EHA current is less than -14mA or more than $+21\text{mA}$ for more than 2 minutes</p>	<p>Once threshold limits are exceeded, further compensation/correction is not available and engine control system effectively resorts to 'open loop'.</p>
with adjustment on to its lean limit	<p>Adaptive Lambda pre-control increases EHA current more than 10mA</p>	<p>Engine management system will continue to compensate until threshold limit of $+21\text{mA}$ is exceeded</p>
with adjustment on to its rich limit	<p>Adaptive Lambda pre-control reduces EHA current more than -5mA</p>	<p>Engine management system will continue to compensate until threshold limit of -14mA is exceeded</p>
and/or its ineffective	<p>Synchronisation lost</p>	<p>Dependent upon ECU data update prior to engine reference sensor failure</p>

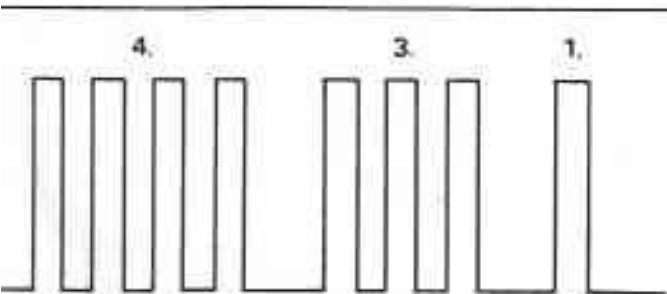

should not sound.

9. With the throttles fully open the multi-meter buzzer should sound.

10. The switching point should be at approximately 72° of throttle plate rotation.

Fuel injection and ignition system maps

1. With the engine switched off, disconnect the three way electrical plug to the throttle position switch (see fig. B4-37).

2. Connect a digital multi-meter in 'series' with the electro-hydraulic actuator (EHA), using the adapter RH 9893 (see fig. B4-38).

3. Set the multi-meter to read milliamps.

idle

4. Bridge the black/pink and the blue/purple connection on the ECU side of the throttle position switch connector (see fig. B4-37). The engine will now be governed by the 'idle map' engine management parameters.

5. Fit a stroboscope to the engine in accordance with the manufacturer's instructions.

6. Turn the ignition key from the LOCK to the RUN position and check for the K-Motronic ECU 'stand current' of $100\text{ mA} \pm 2\text{ mA}$.

7. Start and run the engine until normal operating temperature is attained.

8. With the engine running at idle speed and the coolant temperature stabilized above 80°C (176°F), check that the ignition timing is $6^\circ \pm 1^\circ$ btdc at an idle speed of 580 ± 20 rev/min. At the same time the basic compensation current to the EHA should read a stable $0 \pm 1.0\text{ mA}$ on the multi-meter.

Note On cars fitted with catalytic converters the ignition timing should be $8^\circ \pm 1^\circ$ btdc and the basic compensation current to the EHA should be oscillating about a median of zero milliamps.

Part load

9. Remove the bridge cable from the black/pink and the blue/purple connections on the ECU side of the throttle position switch connector (see fig. B4-37).

10. Leave the connector plug and socket disconnected. This ensures that the engine is governed by the 'part load' engine management system parameters.

11. Set the engine speed to 2000 ± 20 rev/min.

12. Ensure that the engine is still fully warmed-up and check that the ignition timing is $14^\circ \pm 1^\circ$ btdc. At the same time the basic compensation current to the EHA should read $-2 \pm 2\text{ mA}$.

Note On cars fitted with catalytic converters the ignition timing should be $27^\circ \pm 1^\circ$ btdc and the basic compensation current to the EHA should be oscillating about a median of zero milliamps. Deviation should be approximately ± 3 milliamps.

13. Stop the engine, remove the test equipment, and connect the throttle position switch connector.

14. If the fuel injection and ignition control system maps do not conform to the specification, refer to the appropriate fault diagnosis charts.

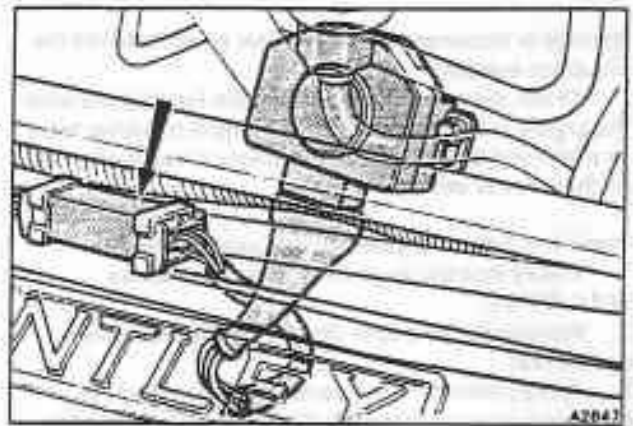

Fig. B4-37 Throttle position switch electrical connection

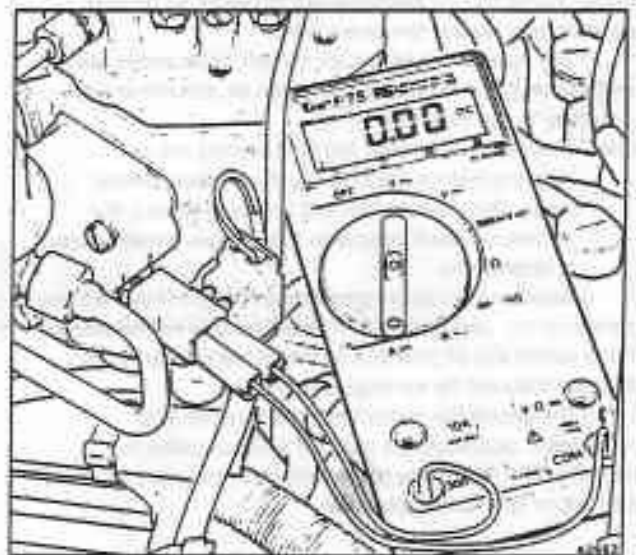

Fig. B4-38 Multi-meter connected in 'series' with the EHA

Diagnosing and correcting faults

The workshop procedure number given before the title of the operation refers to the fault diagnosis chart for the basic KE3 - Jetronic fuel injection system given in figure B4-34.

Before carrying out any tests, ensure that the battery is in a fully charged condition.

It should be noted that all components of the system (except the fuel injectors and cold start injector) can be tested on the vehicle.

Procedure 1 Fuel pump and/or pre-pump not operating correctly

For information relating to these components refer to Chapter C.

Procedure 2 Induction system air leaks

Visually check all vacuum hoses, pipes, and clips for



damage or looseness that may allow an air leak into the induction system.

Check the entire induction system for air leaks with the engine running. Use a suitable length of rubber hose as a listening tube. The leak will often be heard as a high pitched hiss or whistle.

Procedure 3 Metering control unit lever sticking

1. Ensure that the engine temperature is above 20°C (68°F).
2. Remove the air intake elbow from the inlet to the control unit.
3. Apply pressure to the control piston in the fuel distributor for approximately 10 seconds (refer to page B4-22). Switch off the power to the fuel pumps.
4. Press the air sensor plate slowly downwards to its maximum open position. The resistance to this movement should be uniform over the whole range of travel. Allow the air sensor plate to return to its rest position and repeat the operation.

If the resistance to the air sensor plate movement is uniform over the whole range of travel, the metering unit lever is not sticking.

- Note** Always ensure that the fuel pumps are not running before depressing the airflow sensor plate. Otherwise, fuel will be sprayed into the engine on each occasion the airflow sensor plate is depressed.
5. Should the resistance to sensor plate movement be greater in the rest position, it could be due to the plate being either out of position or distorted due to impact damage (caused by an engine misfire).
 6. If the condition described in Operation 5 is confirmed, depressurize the fuel system (refer to page B4-27). Press the plate fully downwards and allow it to return to the rest position.

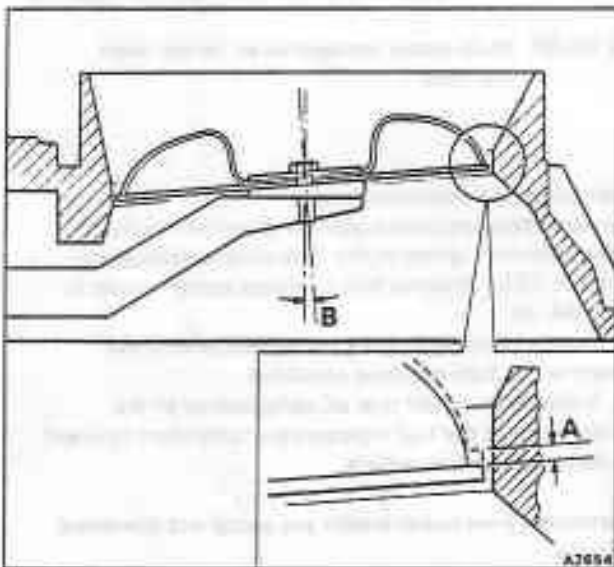

Fig. B4-39 Air flow sensor plate position

- A 1,0mm (0.40in) free play with fuel system pressurized
- B Sensor plate inclination 4.5°

7. Should a resistance be confirmed in Operation 6, remove the air sensor plate and repeat the operation. If this alleviates the resistance, the air sensor plate is fouling the sides of the air funnel and should be centralized (refer to Procedure 4) or the air funnel may be deformed in some way.

8. If there is still a resistance to the movement of the lever, it could be due to contamination within the fuel distributor barrel or occasional binding in the lever mechanism.

9. Contamination within the fuel distributor can be checked by separating the fuel distributor from the control unit for visual inspection.

Do not attempt to remove the control piston.

Remove the retaining screws situated on top of the fuel distributor. Lift off the fuel distributor (resistance will be felt due to the rubber sealing ring).

10. Examine the distributor for contamination.

11. Fit the fuel distributor by reversing the dismantling procedure. Ensure that the rubber sealing ring is in good condition and is lubricated with suitable grease.

Ensure that the retaining screws are evenly tightened.

12. If a resistance is still noticeable, a new assembly should be fitted.

13. After fitting the fuel distributor check the idle mixture strength.

Procedure 4 Positioning the air flow sensor plate

1. Remove the air inlet ducting from above the sensor plate.

2. Check that the sensor plate does not look deformed or damaged, particularly around its outside edge. Also ensure that the sensor plate will pass through the parallel section of the air funnel without fouling.

3. If necessary, loosen the plate securing bolt.

4. Insert the guide ring RH 9609 whilst retaining the sensor plate in the zero movement position. This will prevent the sensor plate from being forced downwards as the centring guide ring is being installed.

5. With the centring guide ring in position, tighten the retaining bolt to 5Nm (0,50kgf m to 0,55kgf m, 44 lbf in to 48 lbf in). Carefully remove the centring guide ring.

6. Apply pressure to the control piston in the fuel distributor for approximately 10 seconds (refer to page B4-42).

7. The air sensor plate should be positioned as shown in figure B4-39, with the plate not protruding above or below the parallel section of the air funnel.

8. If the air sensor plate is too high, carefully tap the guide pin lower (see fig. B4-40), using a mandrel and a small hammer.

Note This adjustment must be made very carefully, ensuring that the pin is not driven too low. Repeated adjustment can loosen the guide pin. Serious damage to the engine could result if the pin should fall out.

Procedure 5 Checking the operation of the idle speed actuator

It is important that the test equipment used to check the idle speed meets the following specification.



Accuracy - Rotational speed within ± 10 rev/min.

1. Start and run the engine until normal operating temperature is attained.
2. Disconnect the 2 way electrical plug connection from the front end of the actuator. The engine speed may drift from the controlled 580 ± 20 rev/min.
3. Hold the actuator body and reconnect the electrical plug. If the actuator is functioning correctly a pulse of armature movement should be felt and the engine idle speed should return to 580 ± 20 rev/min.

Note The return to this idle speed range will not be immediate. A certain amount of incremental engine speed stabilization will take place.

4. If the idle speed actuator control is outside the specifications, refer to the appropriate fault diagnosis flow chart on page B4-49.

Procedure 6 Checking the hot/cold start system

Refer to the modes of operation section and the fault diagnosis flow charts.

Procedure 7 Checking the cold start injector

1. Detach the electrical plug from the cold start injector (see fig. B4-1).
2. Remove the cold start injector from the induction manifold with its feed pipe attached. Place the nozzle of the injector into a suitable clean container so that the operation of the injector can be observed.
3. Produce a test lead using a Bosch electrical plug, two lengths of cable, and a micro-switch.
4. Connect the electrical plug to the cold start injector and the two cables, one to an auxiliary electrical feed and the other to an earth point.

Note Exercise care to eliminate the possibility of an electrical spark (use the micro-switch to make and break the circuit).

5. Apply electrical power to operate the fuel pump (refer to page B4-42).
6. Operate the micro-switch to complete the auxiliary electrical circuit. The cold start injector should spray fuel as the contacts in the micro-switch complete the electrical circuit; if it does not spray fuel, fit a new injector. Operate the micro-switch to break the auxiliary electrical circuit.
7. Dry the nozzle of the cold start injector.
8. Repeat Operation 5 but do not operate the micro-switch. Note that no drops of fuel should form on or drip from the injector nozzle. If the injector is defective a new one should be fitted.
9. Remove the auxiliary test lead from the injector. Fit the injector to the induction manifold and connect the loom plug.

Procedure 8 Checking the operation of the primary fuel circuit

Fuel delivery

1. Depressurize the fuel system (refer to Section A3).
2. Disconnect the fuel return line at the fuel pressure regulator lower connection. Using a 'firtree' type nipple and nut (SPM 1390/1), connect one end of an auxiliary fuel return hose to the connection. Hold the other end of the hose in a graduated measuring container capable of

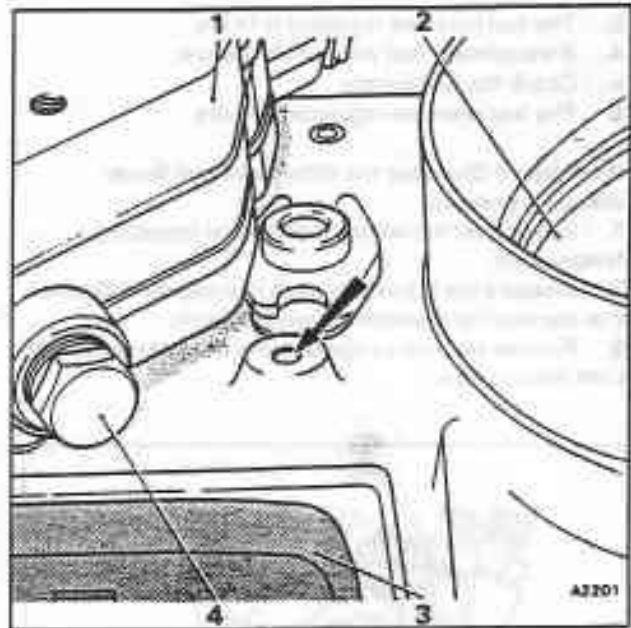

Fig. B4-40 Height adjustment for the air flow sensor plate

- 1 Fuel distributor
- 2 Air flow sensor plate
- 3 Electro-hydraulic actuator (EHA)
- 4 Lower chambers pressure tapping

- holding more than 10 litres (2.2 imp gal, 2.6 US gal).
3. Apply electrical power to operate the fuel pumps (refer to page B4-42). At least 10 litres (2.2 imp gal, 2.6 US gal) of fuel should be delivered into the measuring container within 5 minutes.
4. If the delivery quantity is satisfactory, check the primary system pressure. However, if the delivery quantity is below the prescribed amount proceed as follows. Check the fuel pump delivery after each operation.
5. Check the voltage at the fuel pump. When the pump is operating this should be 11.5 volts.
6. Fit a new 'in-tank' filter.
7. Fit a new main fuel filter.
8. Check the fuel lines for blockage.
9. Fit a new fuel pre-pump.
10. Fit a new fuel pump.
11. After establishing that the fuel delivery is correct, remove the test equipment.
12. Connect the fuel return pipe.

Primary system pressure

To carry out this test, fit the pressure tester RH 9873 as shown in figure B4-46.

1. Apply electrical power to operate the fuel pumps (refer to page B4-42).
2. The pressure gauge will show primary system pressure which should be between 6,2 bar and 6,4 bar (89.9 lbf/in² and 92.8 lbf/in²).
3. If the primary fuel pressure is too high.
 - a. Check for a restriction in the fuel return line to the tank.



- b. The fuel pressure regulator is faulty.
- 4. If the primary fuel pressure is too low.
 - a. Check the fuel supply.
 - b. The fuel pressure regulator is faulty.

Procedure 9 Checking the differential fuel (lower chamber) pressure

1. Ensure that the engine is at normal operating temperature.
2. Measure the primary system fuel pressure. Ensure that the reading is within the specification.
3. Remove the test equipment and re-connect the cold start injector pipe.

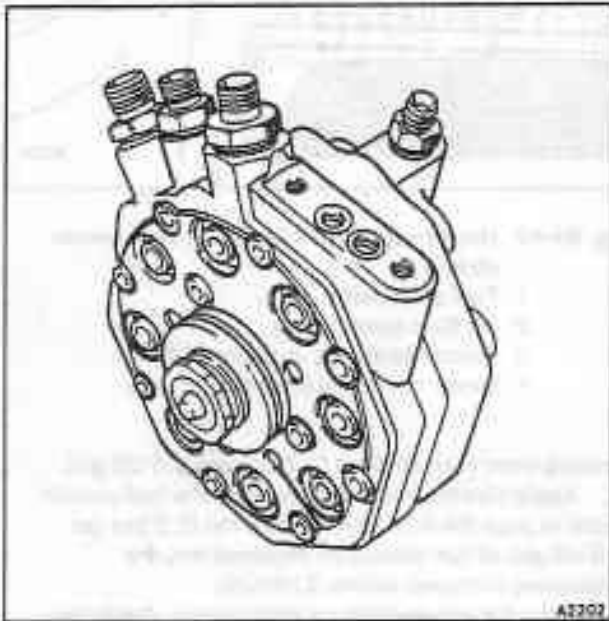

Fig. B4-41 Fuel distributor removed

4. Install the pressure tester RH 9873 as shown in figure B4-47.
5. Apply electrical power to operate the fuel pump for 30 seconds (refer to page B4-42). Switch off the power to the fuel pump.

The gauge will now show the differential pressure valve lower chamber pressure which should be between 5,7 bar and 5,9 bar (82.7 lbf/in² and 85.5 lbf/in²).

6. If the differential fuel pressure is outside the specified limits.
 - a. The fuel pressure regulator is faulty.
 - b. The fuel metering unit is faulty.
 - c. The electro-hydraulic actuator (EHA) is faulty.
 - d. The mA supply to the EHA is incorrect (refer to Fuel injection and ignition system maps).

Procedure 10 Check the fuel system for leaks

The engine should be at normal operating temperature for this test.

1. Fit the pressure tester RH 9873 as shown in figure B4-46.
2. Apply electrical power to operate the fuel pump for 30 seconds (refer to page B4-42).
3. Allow the primary system pressure to build-up. Switch off the power to the fuel pump.
4. Note the time it takes for the pressure to fall to zero and compare this with the graph for fuel system 'leak-down' (see fig. B4-42).
5. If the pressure loss is outside the acceptable limits, the leak may be due to.
 - a. Defective pressure regulator.
 - b. Leaking cold start injector.
 - c. Faulty non-return valve in the fuel pump.
 - d. Leaking accumulator diaphragm.
 - e. An external leak from one of the fuel system pipes.
 - f. One or more of the fuel injectors leaking.

Procedure 11 Checking the injectors

Cleanliness of components and their connections cannot be over emphasized for this test.

1. Clean all external fuel connections before removing the fuel injectors.
2. Remove the fuel injectors from the engine.
3. Connect one injector to the test equipment RH 9614 (Bosch Number KDJE 7452). Refer to figure B4-43.

Opening pressure

4. Bleed the discharge tube by moving the operating lever several times with the union slacked. Tighten the union.
5. Check the injector for dirt by operating the lever slowly at approximately one stroke per 2 seconds with the valve on the pressure gauge open.

If the pressure does not rise to between 1,0 bar and 1,5 bar (14.5 lbf/in² and 21.8 lbf/in²) the valve of the injector has a bad leak, possibly caused by dirt.

Attempt to flush the valve by operating the lever rapidly several times. If the injector valve does not clear the injector should be discarded.

6. Check the opening pressure of the injector by closing the valve of the test equipment. Bleed the

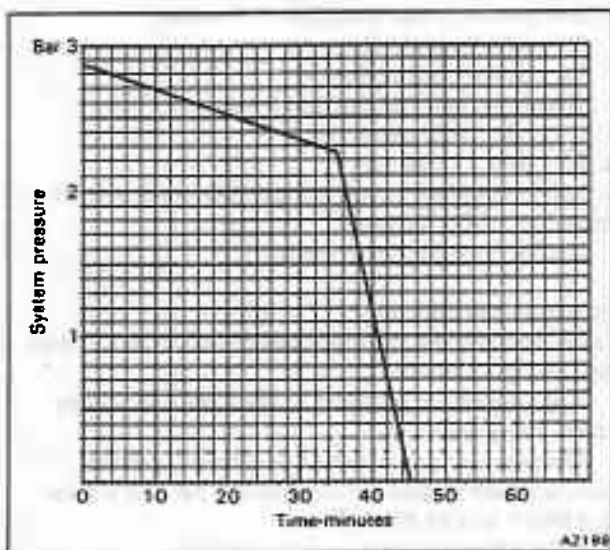

Fig. B4-42 Fuel system 'leak down'

injector by operating the test equipment lever rapidly several times. Open the valve and move the lever slowly at approximately one stroke per 2 seconds. Note the pressure at which the injector begins to spray.

The correct pressure for the injector to commence spraying is between 3,9 bar and 4,1 bar (56.5 lbf/in² and 59.4 lbf/in²).

Leakage test

7. Open the valve on the test equipment and slowly operate the lever until the pressure reading is 0,5 bar (7.3 lbf/in²) below the previously determined opening pressure.

8. Hold this pressure constant by moving the lever.

9. No drips should appear from the injector for the next 15 seconds.

Evaluation of spray and 'chatter' test

10. Operate the lever of the test equipment at one stroke per second. As this is done, the valve in the end of the injector should be heard to 'chatter'.

11. The injector should produce an even spray with an approximate spray angle of 35°. If drops form at the mouth of the injector valve, or if the spray is excessively one-sided, the injector should be discarded.

The various spray formations and angles are shown in figure B4-44.

Repeat Operations 1 to 11 inclusive on the remaining injectors noting that only new test fluid must be used to replenish the reservoir of the test equipment.

Procedure 12 Checking the delivery balance of the fuel distributor

1. Fit the delivery quantity comparison tester RH 9613 (Bosch Number KDJE 7455).

2. Remove the air intake elbow to reveal the air sensor plate.

3. Apply electrical power to operate the fuel pump and build-up pressure in the system (refer to page B4-42).

4. Bleed the test equipment.

5. This test is carried out under simulated idle, part load, and full load conditions as follows.

Note The test equipment rotameter scale may read either ml/min or cm³/min. Whichever scale is used, the flow figures are identical (i.e. 1ml/min = 1 cm³/min).

Idle conditions

6. Press switch number one on the test equipment and move the air flow sensor plate downwards (using the adjusting device shown in figure B4-45) until the reading on the small rotameter indicates a flow of approximately 6,7 ml/min.

7. Test the remaining outlets and determine which one has the lowest fuel delivery.

8. Press the switch of the outlet with the lowest fuel delivery and using the adjusting device, adjust the height of the air flow sensor plate until the reading on the rotameter is 6,7 ml/min.

9. Measure the fuel delivery from each outlet, noting that none of them should exceed 7,7 ml/min.

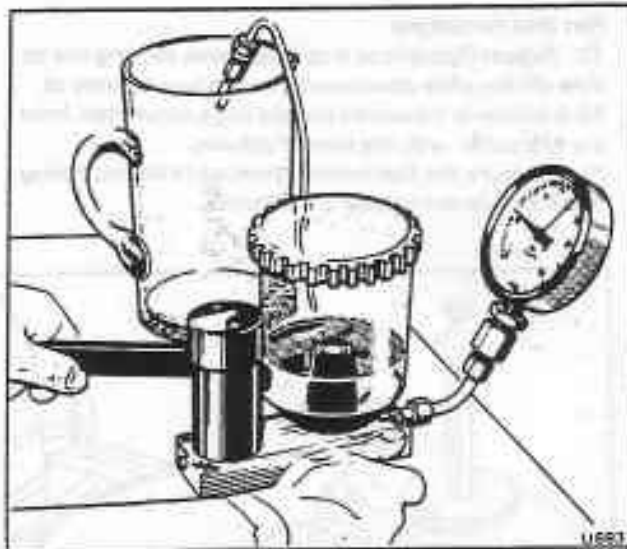

Fig. B4-43 Testing an injector

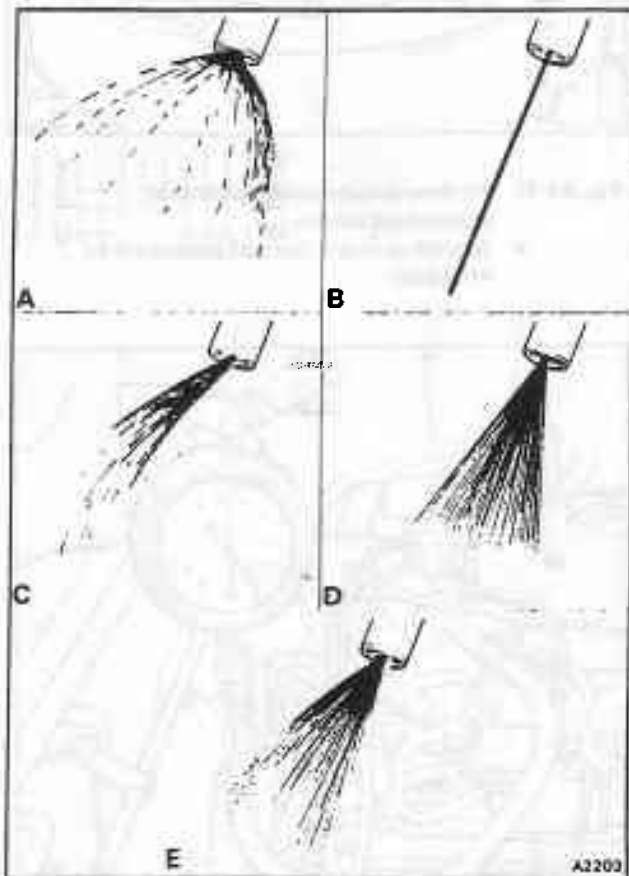

Fig. B4-44 Injector spray patterns
Unacceptable spray patterns
 A Drop formation
 B Cord spray
 C Spray in strands
Acceptable spray patterns
 D Good spray formation
 E Single-sided but still a good spray formation



Part load conditions

10. Repeat Operations 6 to 9 inclusive, moving the air flow sensor plate downwards, until a fuel delivery of 20,8 ml/min is measured (on the large rotameter) from the fuel outlet with the lowest delivery.

11. Measure the fuel delivery from each outlet, noting that it should not exceed 22,4 ml/min.

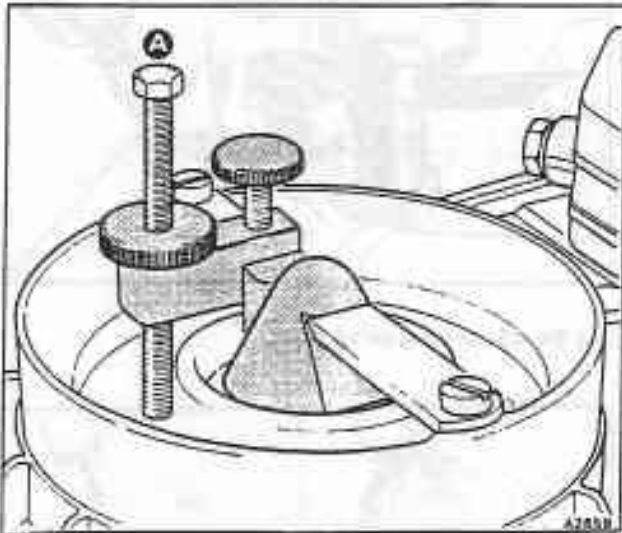

Fig. B4-45 Air flow sensor plate movement adjustment device

- A Adjusting screw (part of accessory kit RH 9960)

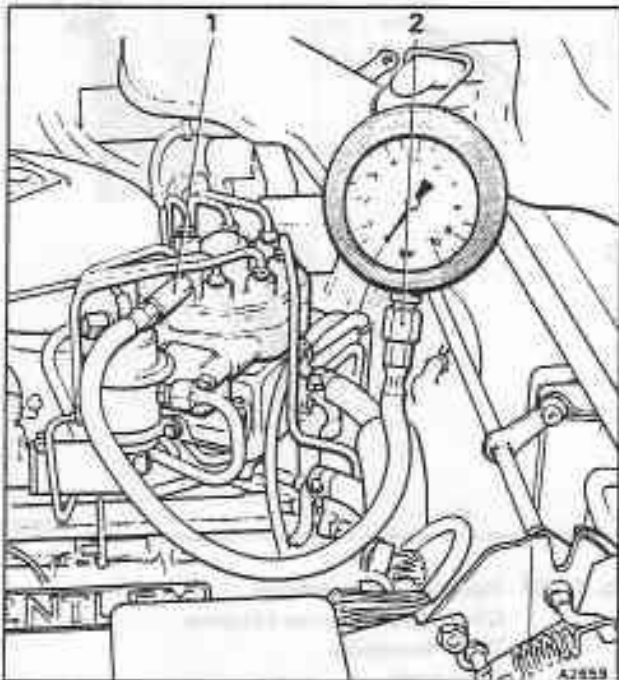

Fig. B4-46 Pressure tester equipment - testing for leaks or primary system pressure

- 1 Pressure gauge assembly RH 9873
2 Special adapter RH 9881

Full load conditions

12. Repeat Operations 6 to 9 inclusive, moving the air flow sensor plate further downwards, until a fuel delivery of 94 ml/min is measured from the fuel outlet with the lowest delivery.

13. Measure the fuel delivery from each outlet, noting that it should not exceed 99 ml/min.

If the fuel delivery exceeds the limits quoted, a new distributor should be fitted.

Procedure 13 Checking the operation of the throttle plates

1. Depress the accelerator pedal fully and observe the position of the throttle levers.
2. Ensure that the throttle levers are fully open (i.e. against the stops).
3. Also, ensure that the throttle linkage operates smoothly through both primary and secondary stages.
4. If the throttles do not open fully, or if the linkage does not operate smoothly, the problem should be investigated and corrected as described in Chapter K.

Procedure 14 Checking the fuel accumulator diaphragm for a leak

1. Locate the flexible hose connecting the accumulator to the fuel tank return pipe.
2. Suitably clamp the hose to prevent unpressurized fuel from flowing out during the test.
3. Unscrew the worm drive clip securing the flexible hose to the connection on the fuel accumulator.
4. Withdraw the hose from the connection.
5. Apply electrical power to operate the fuel pump (refer to page B4-42) and pressurize the fuel accumulator.
6. Ensure that no fuel flows from the open connection on the fuel accumulator during the test.
7. If fuel does flow from the open connection, the accumulator diaphragm is leaking and a new fuel accumulator must be fitted.
8. Connect the fuel pipe and remove the clamp.

Procedure 15 Blocked air filter or ducting

1. Remove the air filter element.
2. Examine the condition of the element and fit a new one if necessary.
3. Inspect the filter housing assembly.
4. Inspect the intake 'scoop' that diverts air from below the front bumper assembly into the filter housing (refer to Chapter J). Ensure that the flow of air is not restricted.
5. Inspect the intercooler matrix (refer to Chapter J). Ensure that the matrix is not blocked, thus restricting either the flow of cooling air or the flow of intake air.
6. Slacken the worm drive clips and free each section of flexible hose in turn. Ensure that each section is in good condition and not restricted.
7. Ensure that the air intake elbow is not restricted.
8. Spin the compressor blades of the turbocharger assembly to ensure that the blades rotate freely.
9. Carry out the test given in the Workshop procedures 4 and 13.
10. Fit all hoses, clips, and the filter element upon

satisfactory completion of the tests.

Fault diagnosis test equipment and special procedures

This section contains information relating to the fitting procedures for the test equipment used when diagnosing a fault. Also included are the special procedures associated with the fuel injection system.

Depressurizing the fuel system

The fuel in the system may be pressurized. Therefore, it is recommended that the fuel system be depressurized before commencing any work that involves dismantling parts of the system.

The depressurizing procedure is given in Section A3.

Fuel injection system - pressure tester

The pressure tester equipment (see figs. B4-46 and B4-47) should be connected into the cold start injector feed line, on top of the fuel distributor or the lower differential pressure valve tapping point.

With the gauge connected at these points, the fuel system can be checked for.

- Fuel system leakage either internal or external (see fig. B4-46).
- Primary system fuel pressure (see fig. B4-46).
- Differential fuel pressure (see fig. B4-47).

Installation of the test equipment

- Carry out the usual workshop safety precautions.
- Switch on the ignition. Ensure that the gear range selector is in the park position. Switch off the ignition and withdraw the gear range selector fuse (A6) from fuseboard F2.
- Disconnect the battery.
- Depressurize the fuel system.
- The pressure gauge may now be connected to the fuel distributor as shown in either figure B4-46 or B4-47. Ensure that all pipe nuts and unions are tight.

Bleeding the test equipment

After fitting, but prior to using the test equipment always ensure that it is properly bled as follows

- Apply electrical power to operate the fuel pump (refer to page B4-42).
- Allow the gauge to hang down under its own weight with the flexible hose fully extended, for a few seconds.
- Lift up the gauge and suspend it from a suitable point.
- The pressure tester equipment is now ready for use.

Fuel delivery quantity comparison tester

If there is any discrepancy in the quantity of fuel delivered by the individual fuel distributor outlets, it can be measured by a comparison test, using the test equipment RH 9613 (Bosch Number KDJE 7455), refer to figure B4-48.

The test equipment is designed in such a way that the tests can be carried out without removing the fuel distributor from the engine.

Ideally, the tester should be set permanently on a

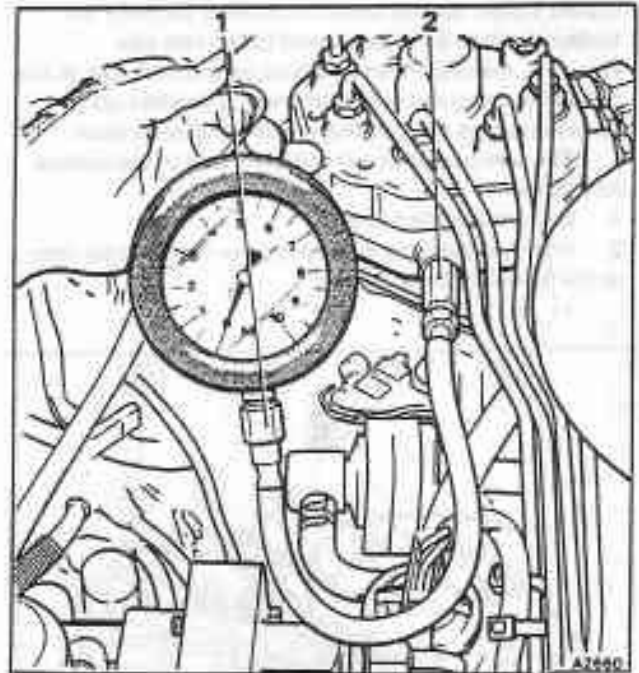

Fig. B4-47 Pressure tester equipment - testing differential (lower chamber) pressure
 1 Pressure gauge assembly RH 9873
 2 Special adapter RH 9881

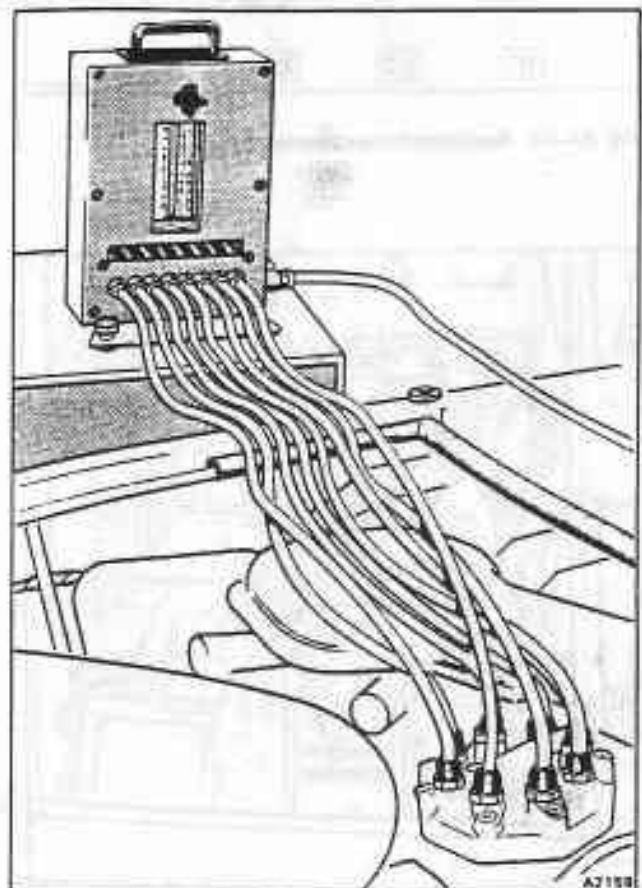

Fig. B4-48 Installation of comparison tester



mobile trolley, so that once it is levelled-up, only the trolley needs to be manoeuvred to the test site. However, the tester can be set up on a table close to the test vehicle and the test equipment is levelled-up for each test using the levelling screws and spirit level.

The test equipment should be fitted to the vehicle as follows.

1. Disconnect the battery.
2. Unscrew the unions securing the fuel injector lines to the fuel distributor outlets.

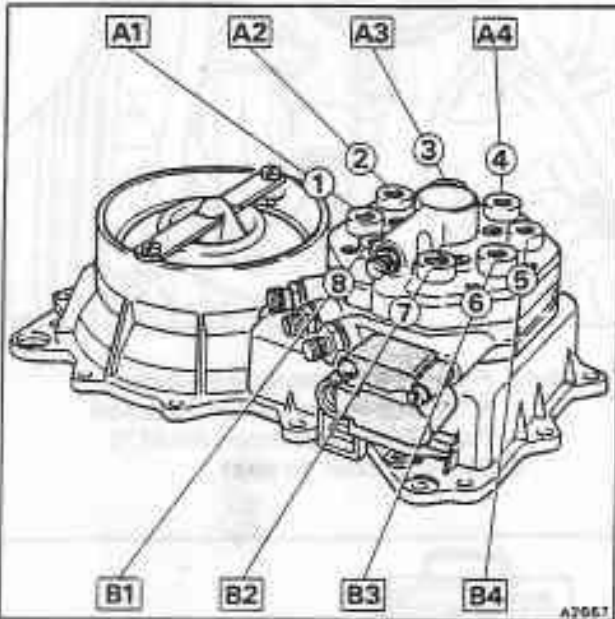

Fig. B4-49 Fuel distributor connections

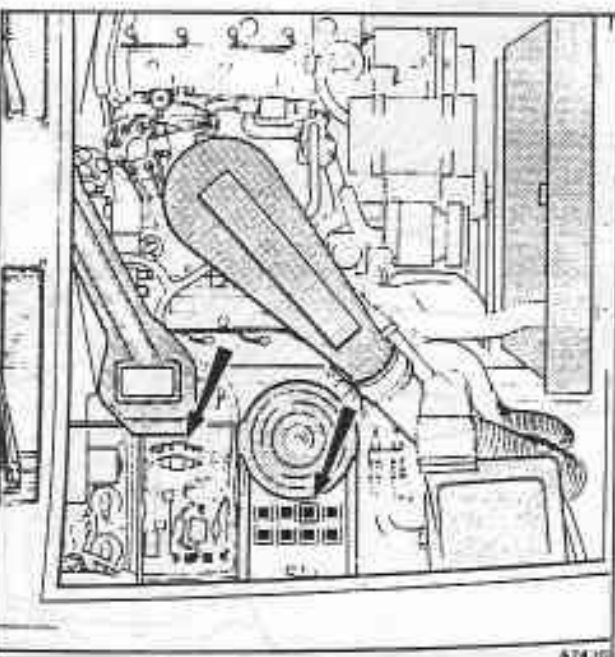

Fig. B4-50 ECU and relay compartments

3. Screw the special adapters supplied with accessory kit RH 9960 into the fuel distributor outlets.

4. Fit the automatic couplings fastened on the ends of the test equipment to the special adapters in the fuel distributor outlets.

Note Outlet one from the distributor should always be nearest to the fuel inlet connection. Figure B4-49 indicates which test line and switch of the test equipment are connected to which engine cylinder.

5. Route the fuel return pipe across the engine, along the side of the car and into the filler for the fuel tank.

6. Connect the battery.

Note The condition of the battery is critical for this test. Therefore, always check the state of charge of the battery.

7. Apply electrical power to operate the fuel pump (refer to page B4-42).

8. To bleed the test equipment, remove the air intake ducting from the mixture control unit and push the air flow sensor plate downwards to its fully opened position. Press each key on the flowmeter one after the other, whilst simultaneously operating the three-way tap. Continue this operation until there are no bubbles in the two rotameters.

9. Allow the air sensor plate to return to the zero position.

The test equipment is now ready for use.

10. To remove the test equipment, depressurize the system and reverse the procedure.

Apply fuel pressure to the system

1. Carry out the usual workshop safety precautions.
2. Ensure that the automatic air conditioning system is switched off. Remove fuse A1 from fuseboard F1.
3. Remove the ECU compartment cover situated to the rear of the right-hand front road spring cover.
4. Disconnect the oxygen sensor (if fitted) inside the ECU compartment (see fig. B4-50).
5. Withdraw the fuel pumps relay located inside the ECU compartment (see fig. B4-50).
6. Produce a short bridge cable containing a micro-switch. The micro-switch is used to 'make' and 'break' the test circuit, thus eliminating the possibility of a spark.
7. Ensure that the contacts in the micro-switch are not 'made' (i.e. the bridge cable is open circuit).
8. Bridge the pink and white/pink cable in the relay base, using the auxiliary bridging cable. Complete the circuit by operating the micro-switch. The fuel pumps will now run and pressurize the system.

Removal and fitting of components

Before dismantling any connections and removing any components always depressurize the system and carry out the usual workshop safety precautions.

Always blank off any open connections to prevent the ingress of dirt.

Mixture control unit (see figs. B4-51 and B4-52)

The mixture control unit comprises the air meter and fuel distributor.



situated on top of the distributor.

5. Lift the fuel distributor from the mixture control unit and collect the rubber sealing ring (resistance will be encountered due to the rubber sealing ring).
6. Do not remove the control piston from the fuel distributor.
7. Fit the fuel distributor by reversing the removal procedure, noting that the rubber sealing ring fitted in between the fuel distributor and mixture control unit must be in good condition. If in doubt, fit a new sealing ring. When installing the sealing ring ensure that it is lubricated with a suitable grease and that it does not

become trapped when the fuel distributor is fitted. This could cause a subsequent air leak which may be difficult to detect.

8. Check the idle mixture strength.

Mixture control unit - To remove and fit
(see figs. B4-51 and B4-52)

1. Carry out the usual workshop safety precautions, including disconnecting the battery and depressurizing the fuel system.
2. Unscrew the worm drive clips securing the air intake hose to the cast elbow. Free the joint.

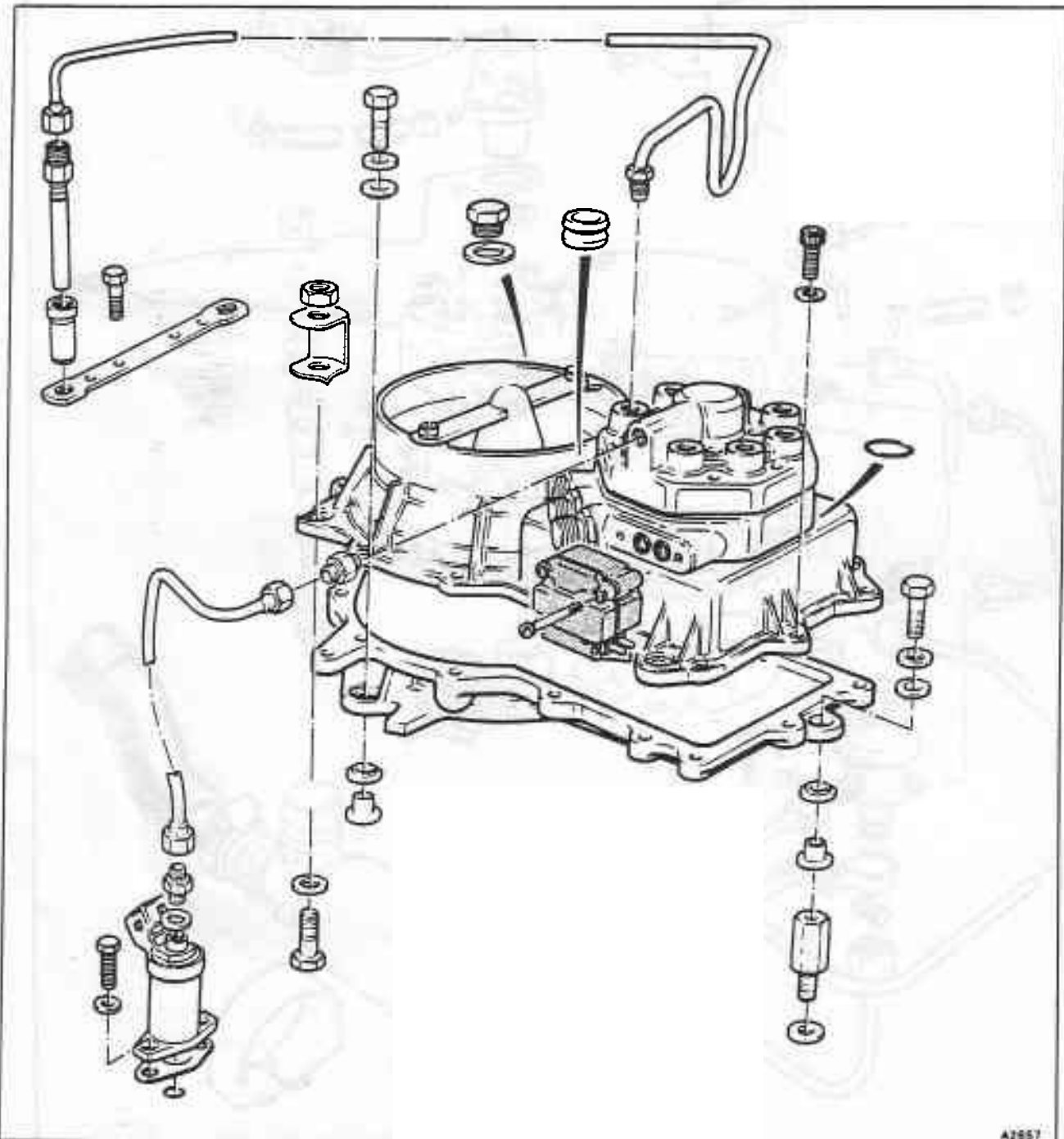

Fig. B4-52 Fuel distributor and associated compartments



3. Unscrew the worm drive clips securing the dump valve flexible hose to the return pipe. Free the joint.
4. Free the small diameter signal hoses to the dump valve.
5. Unscrew the two setscrews retaining the cast intake elbow via its mounting brackets to the mixture control unit.
6. Withdraw the intake elbow and rubber sealing ring.
7. Unscrew the injector pipe nuts from the top of the fuel distributor. Free the pipes.
8. Unscrew and remove the following connections on the fuel distributor.
 - a. Fuel supply to fuel distributor.
 - b. Fuel supply to cold start injector.
 - c. Small diameter pipe between the fuel distributor and the pressure regulator.
9. Unscrew the pipe nut securing the fuel return pipe to the bottom of the pressure regulator.
10. Unscrew the two mounting setscrews, one at the front and one at the rear of the unit.
11. Detach the electrical cables to.
 - a. The electro-hydraulic actuator.
 - b. The air flow sensor potentiometer.
 - c. The dump valve solenoid valve.
 - d. The dump valve vacuum switch.
12. Free the small diameter signal hoses to the solenoids and vacuum switches.
13. Unscrew the rear mounting nut (situated under the dump valve solenoid) and the front mounting setscrew (situated under the dump valve).
14. Carefully lift the assembly from the engine with the ancillary units still attached.
15. Remove the upper section of the mixture control unit from the lower half (air outlet duct) by unscrewing the cap nuts situated around the face joint.
16. Fit the assembly by reversing the procedure given for removal, noting that the face joint between the two halves of the assembly should be clean and coated with Wellseal.
17. Ensure that any rubber sealing rings that have been disturbed are in good condition.

Note Whenever a hose or an electrical plug is disconnected, it is advisable to attach an identification label to facilitate assembly.
In addition any open connections should be blanked as soon as possible to prevent the ingress of dirt.

Throttle body - To service

To remove, fit, and overhaul the throttle body refer to Chapter K.

Idle speed actuator - To remove and fit (see figs. B4-24 and B4-51)

1. Carry out the usual workshop safety precautions.
2. Disconnect the electrical plug.
3. Unscrew the worm drive clips securing the two hoses to the actuator. Free the joints.
4. Carefully slide the actuator from its rubber mounting.
5. Fit the idle speed actuator by reversing the removal procedure.

Cold start injector - To remove and fit (see figs. B4-10 and B4-52)

1. Carry out the usual workshop safety precautions, including disconnecting the battery and depressurizing the fuel system.
2. Detach the electrical plug from the cold start injector.
3. Unscrew the union connecting the fuel feed pipe to the injector.
4. Unscrew the two small setscrews retaining the injector in position. Collect the washer from each setscrew.
5. Withdraw the injector and collect the rubber sealing ring.
6. To fit the cold start injector reverse the procedure given for removal.

Injector - To remove and fit (see figs. B4-9 and B4-52)

There are eight injectors fitted to the engine one for each cylinder. The removal and fitting procedure given below is for one injector but the instructions apply equally to all of the injectors.

1. Carry out the usual workshop safety precautions, including disconnecting the battery and depressurizing the fuel system.
2. Free the loom rail from the respective side of the engine. Manoeuvre the rail away to gain access to the injectors.
3. Unscrew the union connecting the fuel line to the injector.
4. Unscrew the two setscrews securing the injector retaining plate to the cylinder head.
5. Remove the plate and withdraw the injector.
6. Fit the injectors by reversing the procedure given for removal, noting that the rubber insulating sleeve must be in good condition.

It is essential to check the spray patterns of the injectors before they are fitted.

New injectors must be thoroughly flushed out before they are tested.

Fuel pressure regulator - To remove and fit (see figs. B4-12 and B4-51)

1. Carry out the usual workshop safety precautions, including disconnecting the battery and depressurizing the fuel system.
2. Unscrew the pipe nuts of the three connections to the assembly.
3. Unscrew the small setscrew retaining the regulator to its mounting bracket.
4. Withdraw the assembly.
5. Fit the regulator by reversing the removal procedure.

Electro-hydraulic actuator - To remove and fit (see fig. B4-17)

1. Carry out the usual workshop safety precautions, including disconnecting the battery and depressurizing the fuel system.
2. Remove the fuel pressure regulator.
3. Unscrew the two special (non-magnetic) retaining screws and withdraw the actuator.



4. Fit the actuator by reversing the removal procedure, noting the following.
 - a. Always ensure that the rubber sealing rings are in good condition.
 - b. Always use the special non-magnetic screws to secure the actuator in position.

K-Motronic electronic control unit (ECU) - To remove and fit

1. Carry out the usual workshop safety precautions, including disconnecting the battery.
2. Remove the ECU compartment cover situated to the rear of the right-hand front road spring cover.
3. Locate the K-Motronic ECU (see fig. B4-21).
4. Unscrew the two securing screws from the upper end of the ECU.
5. Free the ECU from the retaining clip situated at the lower end of the unit.
6. Disconnect the multi-plug from the lower end of the unit.
7. Fit the ECU by reversing the procedure.

Service adjustment

Preliminary checks

Before carrying out any tuning, the following basic checks should be made.

- a. Check the condition of the sparking plugs.
- b. Ensure that the throttle linkage is correctly set (refer to Chapter K).
- c. Ensure that the throttle position switch is correctly set (refer to Chapter K).
- d. Check all air hoses and connections.
- e. Check the security of the electrical connections to the fuel injection system and ignition control system components.
- f. Ensure that the warnings relating to the running of

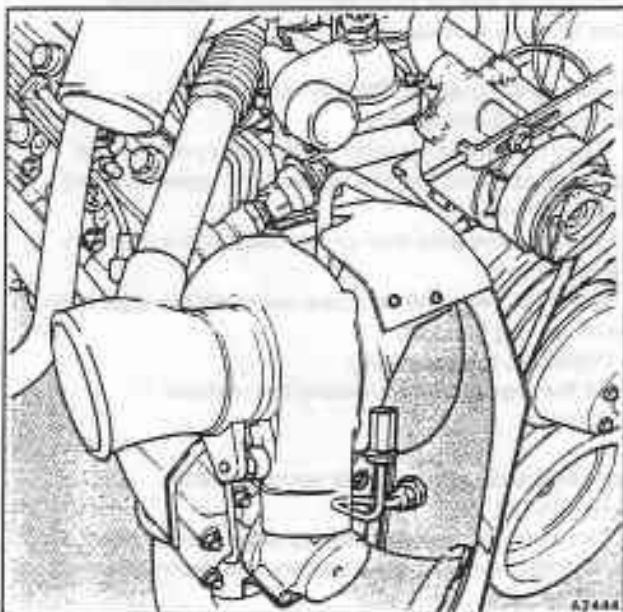

Fig. B4-53 Exhaust CO tapping (Cars fitted with catalytic converters)

turbocharged engines in a workshop environment are understood (refer to Chapter D).

- g. Start the engine and visually inspect the fuel system for leaks.
- h. Whilst the engine is running, check the entire induction system for leaks (refer to this section, Workshop procedure 2).

Before undertaking the tuning procedure, the following work should be carried out.

1. Connect an impulse tachometer and an ignition stroboscope lamp to the engine in accordance with the manufacturer's instructions. These two functions can be accomplished by fitting a compact tester (e.g. Bosch MOT 201) to the engine.
2. Insert the sample probe of a CO meter as far as possible into either exhaust tailpipe.

On cars fitted with catalytic converters, connect the sample probe of the CO meter to the special tapping situated by the turbocharger (see fig. B4-53).

Tuning procedure

If the complete tuning procedure is to be carried out the following sequence of operations is recommended.

- a. Carry out the preliminary checks a to f inclusive.
- b. Turn the ignition key to the RUN position and ensure that the 'Check Engine' warning panel is illuminated. Turn the key to the START position. Ensure that the engine starts and that the 'Check Engine' warning panel extinguishes.

On cars fitted with catalytic converters, if the lamp remains illuminated refer to the 'On-board' fault diagnosis chart (see fig. B4-36).

Note If repeated and/or extended engine cranking is required for a particular diagnostic test, the electrical plug should be disconnected from the cold start injector. This will prevent the sparking plugs becoming fouled due to continued cold start injection operation.

- c. Confirm that the engine is running on all eight cylinders and carry out the preliminary checks g and h.
- d. Ensure that the engine has stabilized at its normal operating temperature.
- e. On cars fitted with catalytic converters, carry out an initial 'open loop' mixture strength check.
- f. Carry out basic fuel and ignition system functional checks. These include checking the operation of the throttle position switch and the system operating maps (refer to this chapter).
- g. Check the operation of the idle speed actuator (refer to this chapter).
- h. Check the operation of the dump valve (refer to Chapter D).
- i. Check and set the idle mixture strength.
- j. * Check the operation and flow rate of the purge control system (refer to Chapter G).
- k. * Check the operation of the air injection system (refer to Chapter F).
- l. * On all cars fitted with catalytic converters, carry out an 'on-board' diagnostic check to confirm that there are no faults stored in the ECU (blink code 4.4.4.4. should register).



Figure B4-55

Idle speed actuator – fault diagnosis chart

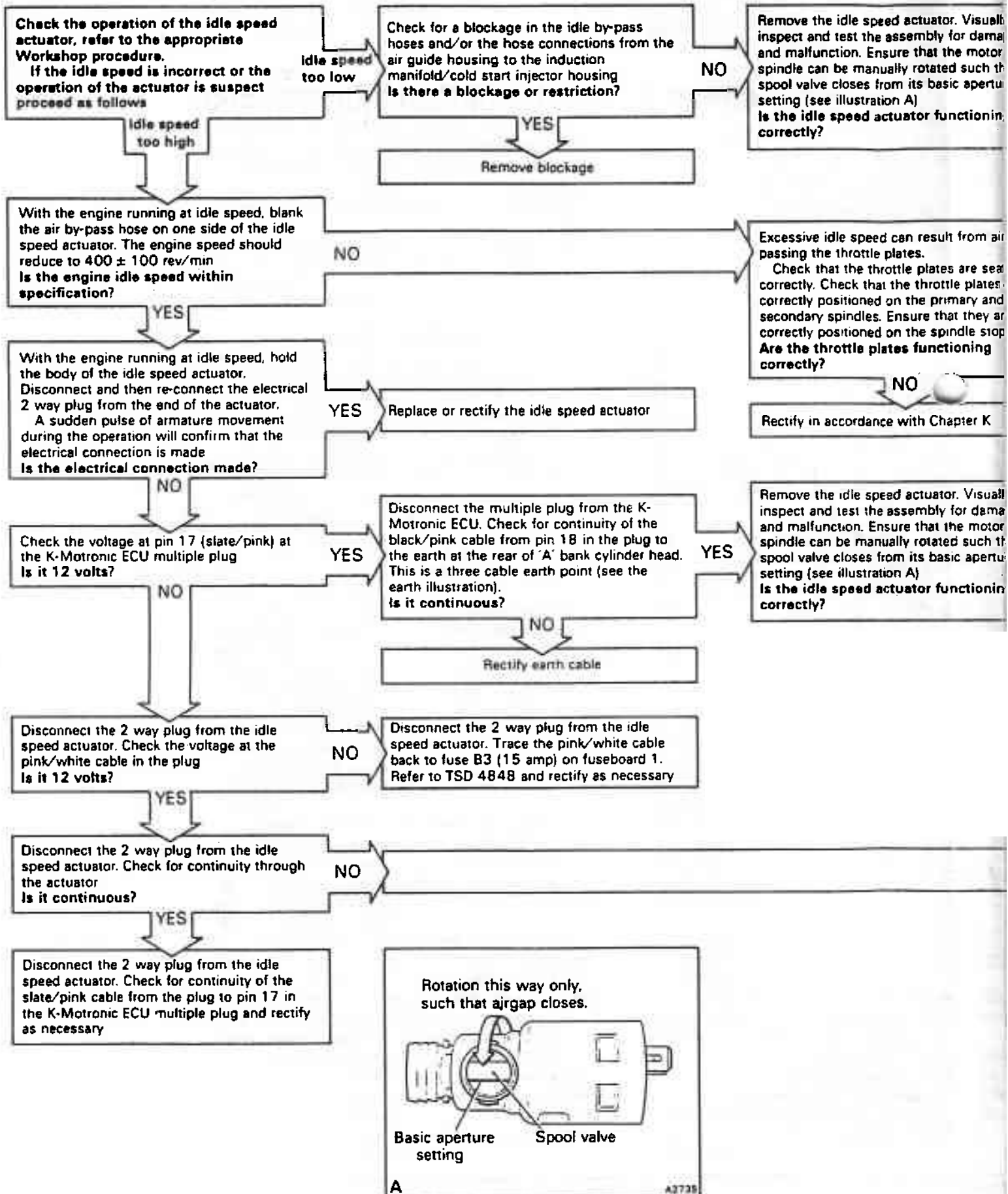

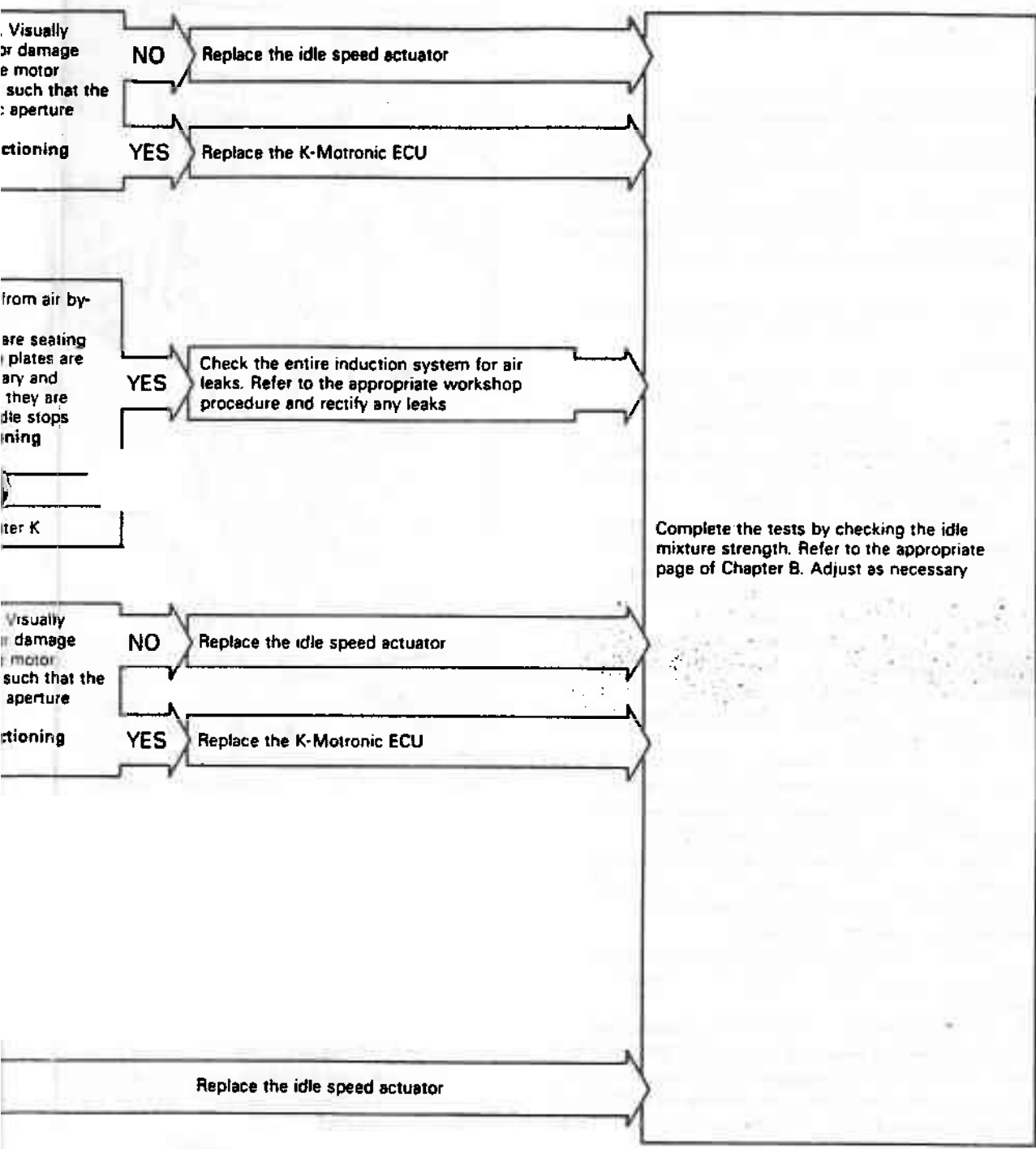

Visually inspect for damage to the motor such that the aperture is not functioning

NO
YES

Replace the idle speed actuator
Replace the K-Motronic ECU

Check for air by-passing. Are the seating plates airtight and do they stop air from entering the cylinder?

YES

Check the entire induction system for air leaks. Refer to the appropriate workshop procedure and rectify any leaks

After K

Complete the tests by checking the idle mixture strength. Refer to the appropriate page of Chapter B. Adjust as necessary

Visually inspect for damage to the motor such that the aperture is not functioning

NO
YES

Replace the idle speed actuator
Replace the K-Motronic ECU

Replace the idle speed actuator



Ignition control system - Workshop servicing information

Health risks

Refer to Section A3, General information for health risk details relating to the ignition control system.

Workshop safety precautions

Refer to Section A3, General information for these details.

Additional information when working on the EZ 58F ignition control system

1. Do not start the engine unless the battery connections are securely fastened.
2. Do not isolate the battery from the vehicle electrical system when the engine is running.
3. Do not charge the battery whilst it is installed in the vehicle.
4. Always remove the K-Motronic ECU before carrying out any electrical welding work.

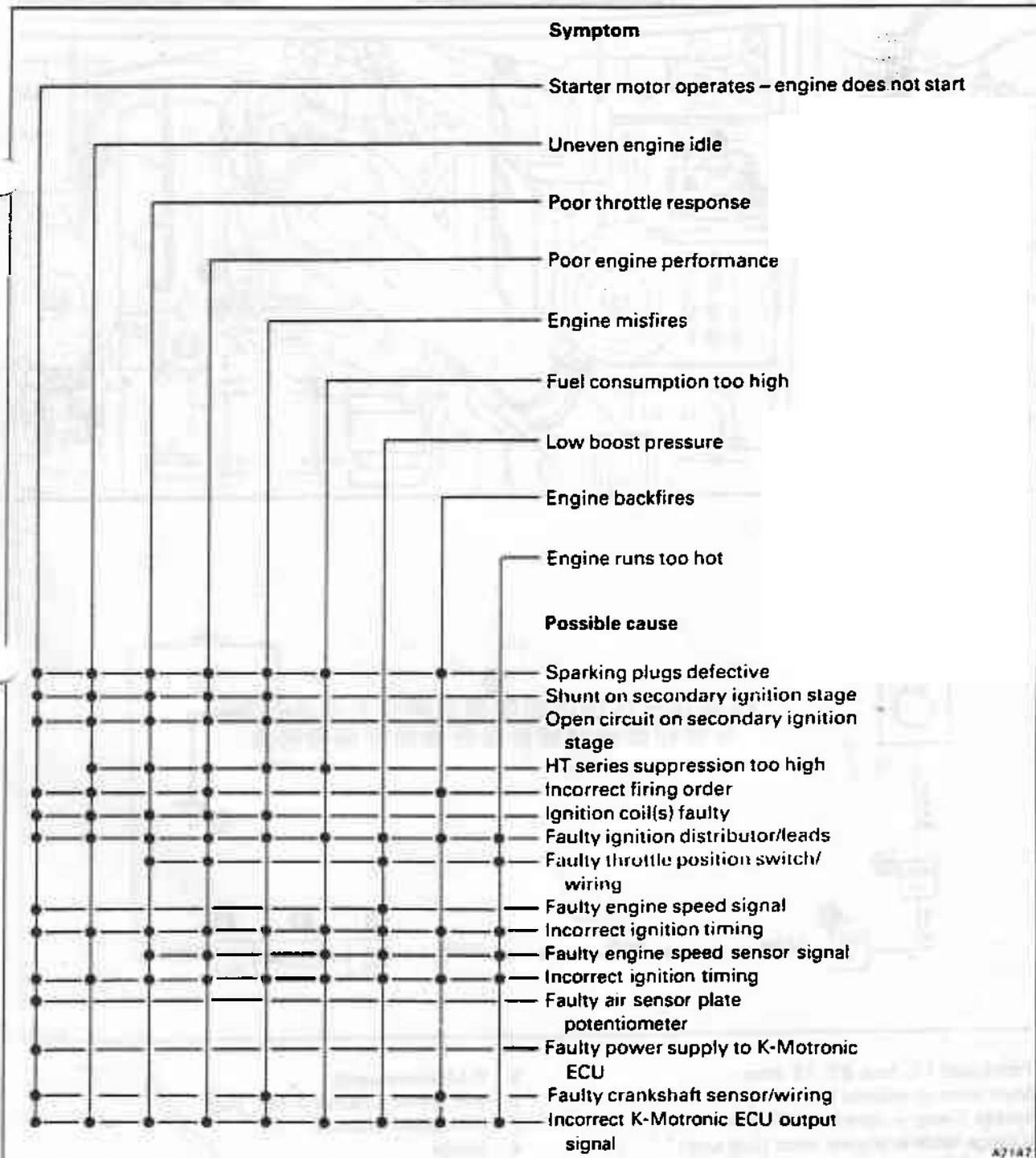

Fig. B4-56 Ignition system fault diagnosis chart



Important

Before carrying out a test ensure that the following conditions apply

- 1 The battery is fully charged
- 2 Use a multi-meter to carry out the tests
- 3 The ignition is switched off when either disconnecting or connecting electrical connections

- 5 Always remake any connections immediately a test is complete
- 6 Ensure that the fuse listed is intact
- 7 Ensure that the battery is fully charged
- 8 Always ensure a test is satisfactory before moving to the next test

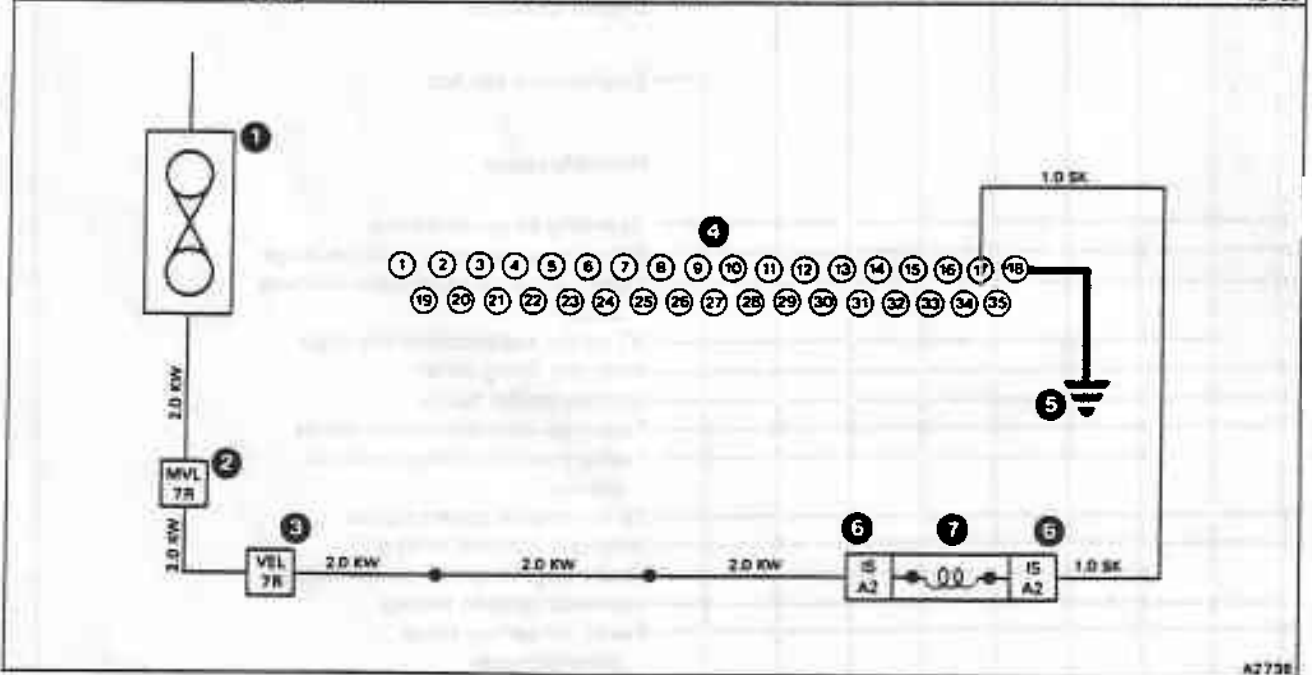
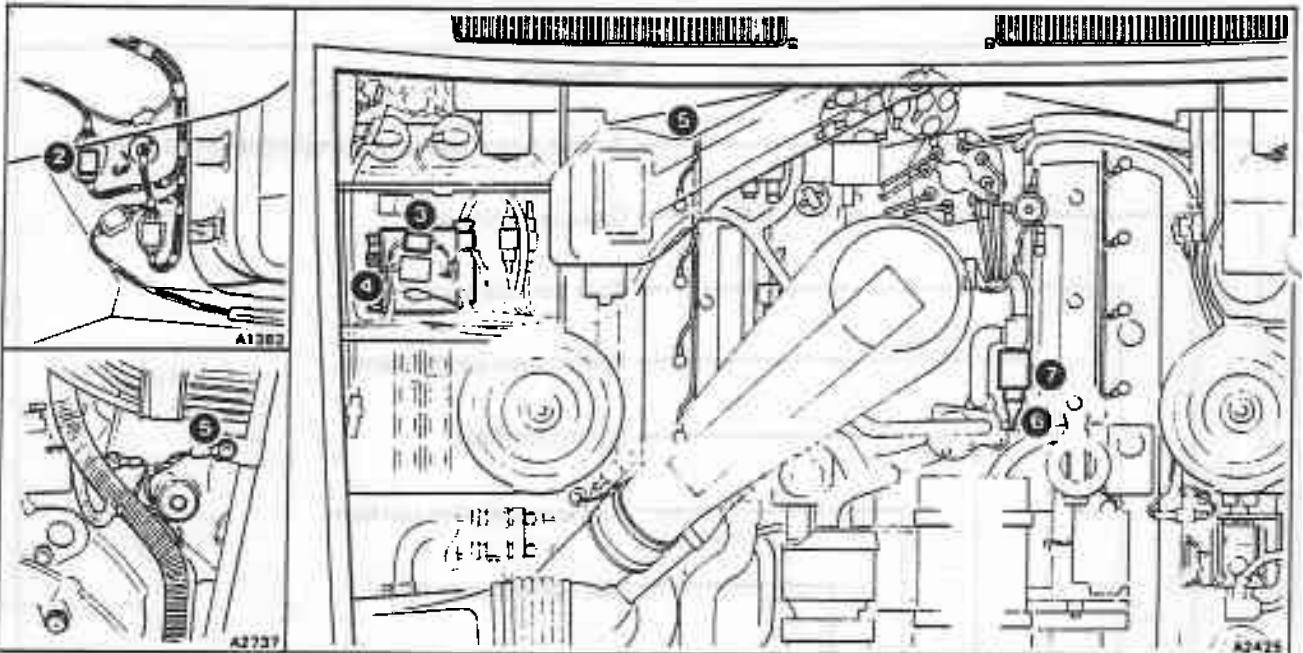

- 1 Fuseboard F1, fuse B3, 15 amp
- 2 Main loom to valance loom plug and socket 7 way - right-hand 'A' post
- 3 Valance loom to engine loom plug and socket 7 way - right-hand side
- 4 K-Motronic ECU

- 5 K-Motronic earth
- 6 idle speed actuator 2 way plug
- 7 Idle speed actuator
- Splice



Running changes No 3 K-Motronic ECU interrogator RH 12210

1989 model year Bentley Turbo R motor cars are equipped with a Bosch K-Motronic engine management system.

The K-Motronic electronic control unit (ECU) provides a self diagnostic fault finding facility for the engine management system.

On cars fitted with full emission control systems including catalytic converters, this fault finding facility is interpreted as a blink code via the fascia mounted CHECK ENGINE warning panel. Refer to Chapter B, Section B4 for full details.

On all other 1989 model year turbocharged cars, the K-Motronic ECU incorporates the self diagnostic capability but there is no 'on-board' facility for displaying the information. To carry out a fault finding check on these cars use test box RH 12210. This test box will interrogate the K-Motronic ECU and exhibit its findings as blink codes on the test box indicator lamp.

The procedure for using the interrogator is as follows.

1. Ensure that the usual workshop safety precautions are carried out.
2. Open the cover to reveal the main fuseboard.
3. Closely inspect the area below and behind the fuseboard (see fig. N4-1). Locate the two cables, one green/yellow, the other black, taped back into the loom. These two cables should be freed and positioned as shown in the illustration.

Note If the ECU has not previously been interrogated by this method it may be necessary to improve access to the loom. Disconnect the battery. Refer to TSD 4848 and release the fuseboard assembly from its mounting. Carefully move the fuseboard assembly into the car to provide the improved access.

If the ECU has been subjected to interrogation by this method previously, the green/yellow and the black cables will be readily accessible and Operations 4 to 7 inclusive omitted.

4. Ensure that the two cables are insulated.
5. Connect the battery.
6. Carry out a thorough road test on the car.
7. Upon return, carry out the usual workshop safety precautions. Ensure that the ignition is switched off and withdraw fuse B5 from fuse panel F1 on the main fuseboard.
8. Connect the test box RH 12210 to the car as shown in figure N4-1.
9. Insert fuse B5 and note that the indicator lamp on the test box is illuminated.
10. Turn the ignition key to the RUN position.
11. Depress the button on the test box for a minimum of four seconds.
12. Release the button and monitor the blink code displayed on the test box indicator lamp.

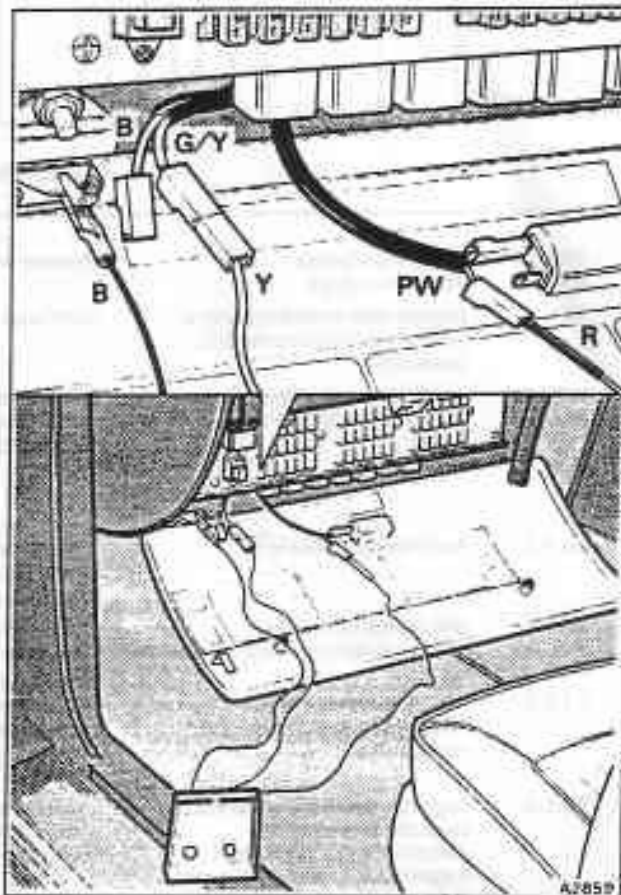

Fig. N4-1 Bosch K-Motronic interrogator in position

The initial period will be 2.5 seconds lamp on and 2.5 seconds lamp off. Afterwards, the fault code will be revealed (see fig. N4-2).

The fault code 4.4.3.1. is shown in the illustration. 13. Once a blink code has been initiated, it will keep repeating the information (with further initiation periods identifying blink code commencement), until the button on the test box is depressed for another four seconds period.

This procedure must be repeated until all stored blink codes have been extracted from the K-Motronic ECU.

14. If there are no more fault codes stored, the condition is identified by the unique code 1.1.1.1. The test box indicator lamp on/off periods for this code are of 2.5 seconds duration.

15. To reset the ECU following fault extraction and/or rectification, isolate the vehicle battery for more than four seconds. Use the master switch located in the luggage compartment, whenever possible.

16. If there are no faults stored in the ECU, the blink

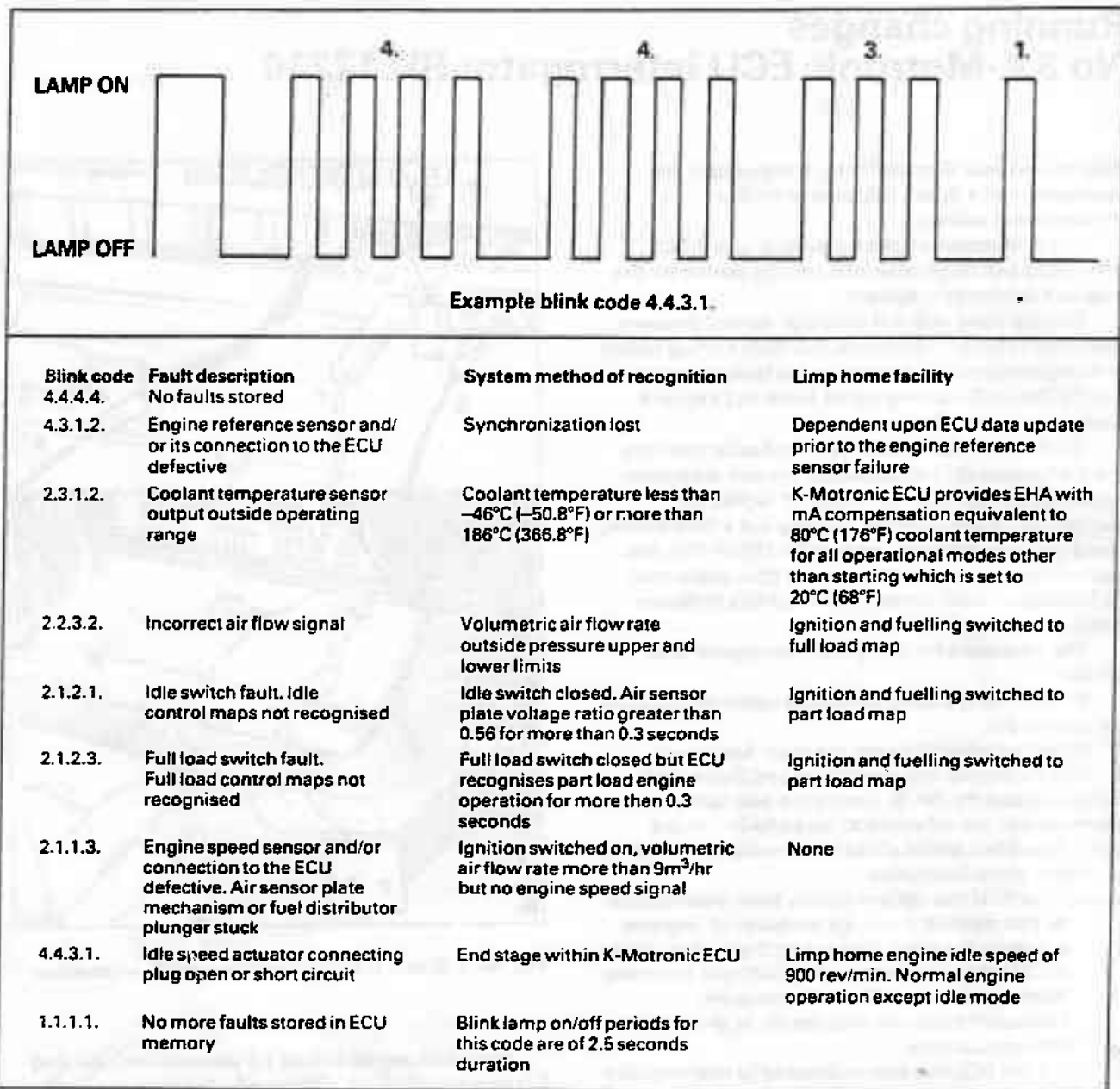

Fig. N4-2 Bosch K-Motronic ECU fault codes

code 4.4.4.4. will register on the test box indicator lamp.

17. Upon completion of the tests, switch off the ignition, withdraw fuse B5 from fuse panel F1 on the main fuseboard, and remove the test box connections.

18. Connect the cable to the fuseboard illumination lamp.

19. Insulate the green/yellow and the black cables. Tape them back to the loom behind the fuseboard, ensuring that they are safe but accessible for future use.

The importance of correctly insulating and stowing these two cables cannot be over emphasized.

The cable connectors must not be allowed to contact other components.

20. Insert fuse B5.

Running Changes

No 4 Atlas Copco belt tension meter RH 12211

When checking the tension of the air pump driving belt, use the Atlas Copco tension meter RH 12211.

The tension meter consists of two main components, the clamping unit, incorporating a hydraulic cylinder and a trigger operated read-out unit (see fig. N5-1).

The tension meter should be fitted close to the mid-point of the drive belt span, as shown in figure N5-2. The procedure for using the tension meter is as follows.

1. Ensure that the usual workshop safety precautions are carried out.
2. Ensure that the engine is cold. A warm engine will return a higher belt tension reading.
3. Inspect the drive belt for either cracks or glazing. Renew the belt if necessary.
4. Examine the back of the drive belt around the mid-point of the span. If any irregularities are found where the clamping unit is to be fitted, rotate the engine until the area of the belt is acceptable.
5. Belt tension readings should always be taken over one belt only. Therefore, the belt blocker should be fitted prior to using the gauge for the first time and thereafter remain in position in the clamping unit (see fig. N5-1).
6. Open the jaws of the clamping unit by applying pressure at the two points indicated by the arrows in figure N5-1.
7. Position the clamping unit with the jaws open, onto the mid-point of the belt span as shown in figure N5-2. Release the clamping unit.
8. Initially, adjust the small Allen screw situated on the top of the clamping unit until the clamping unit will only just slide along the belt. This operation need only be carried out if the clamping unit is a poor fit on the belt.
9. Squeeze the trigger of the read-out unit. The reading displayed on the gauge when the red lamp illuminates is the belt tension.

Repeat this procedure until the clamping unit has settled on the belt and the readings become consistent. Note this figure.

10. Remove the clamping unit from the belt.
11. Rotate the engine.
12. Repeat Operations 6 to 9 inclusive. The average of the two noted readings is the drive belt tension.

If the two readings vary by more than 45 N (10 lbf), take a third reading by again removing the clamping unit, rotating the engine, and repeating Operations 6 to 9 inclusive. Discard the exceptional value and then average the two remaining readings.

13. Do not adjust the drive belt unless the tension has fallen below the minimum acceptable tension of 200 N (40 lbf).

14. If necessary, adjust the belt tension as described in Chapter F, of this Workshop Manual. The air pump

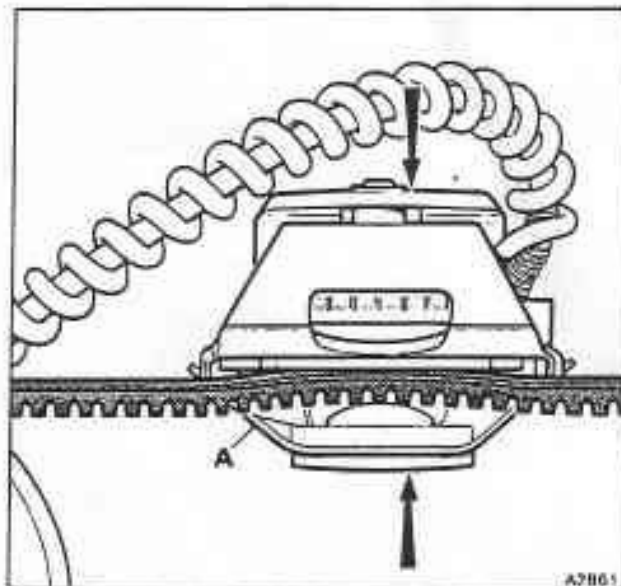

Fig. N5-1 Clamping unit
A Belt blocker

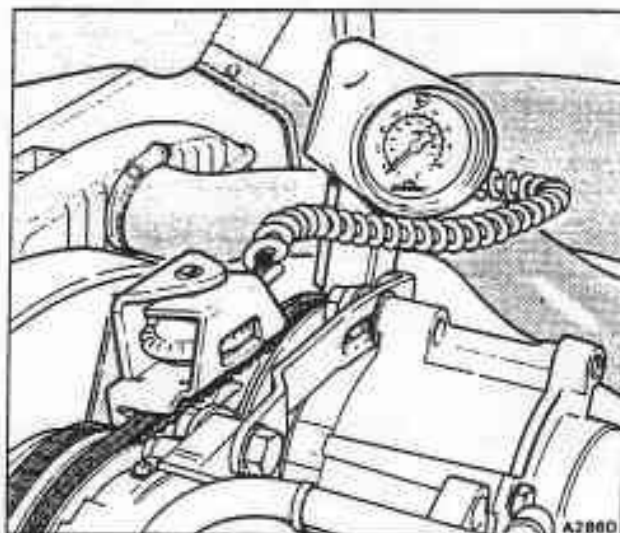

Fig. N5-2 Belt tension meter in position

drive belt should be tensioned to a figure of between 250 N and 300 N (55 lbf and 65 lbf).

15. When adjusting the tension of the drive belt, the following points should be noted.

- a) the belt should be cold.
- b) rotate the engine and check the belt tension several times until a consistent reading is obtained.
- c) the pivot fixings should not be loosened by more than is necessary to allow the belt to be tensioned.



- d) the belt tensioning figures quoted in Operation 14, apply equally to replacement or existing drive belts.
- e) if a new belt has been fitted and tensioned, the belt tension must be checked after the engine has run for 15 minutes.