



Fuel injection system

KE2-Jetronic

The KE2-Jetronic fuel injection system is fitted to turbocharged engines. This is necessary due to the added complexity and increased power output of the engine. The system provides a higher degree of mixture strength control than that provided by the K-Jetronic system.

The KE2-Jetronic system is based upon the mechanical and hydraulic functions of the K-Jetronic system (fitted to naturally aspirated engines) but incorporates electronic control of the air/fuel mixture.

When the engine is operating the accelerator pedal controls movement of the throttle plates, regulating the amount of air drawn into the engine.

An air flow sensor fitted upstream of the throttle plates, monitors the air flow entering the system. Basic engine fuelling requirements are directly related to air flow sensor position. Precise fuel flow is distributed to each cylinder by means of a fuel distributor.

The air flow sensor and the fuel distributor are combined into one assembly known as the mixture control unit (see fig. B3-2).

Metered fuel is continuously sprayed from the injectors, in a finely atomized form, into the inlet port behind each engine inlet valve. The air/fuel mixture is then drawn into the engine cylinders during inlet valve opening periods.

Engine sensors provide the KE2-Jetronic electronic control unit (ECU) with information relevant to coolant temperature, throttle position, manifold pressure, engine speed, and the rate of air sensor plate movement.

The KE2-Jetronic ECU processes incoming signals from the sensors in order to calculate the current supply in milliamps (mA) to the electro-hydraulic actuator (EHA).

The necessary variations in the air/fuel ratio for cold start enrichment, boost pressure enrichment, etc., are achieved by control of the current supply to the EHA. Air/fuel ratio is inversely proportional to the current supply (i.e. an increase in mA supplied to the EHA will reduce the air/fuel ratio (thereby enriching the mixture).

Air flow sensing

The air flow sensor consists of a calibrated air cone in which moves an air flow sensor plate mounted on a pivoted lever (see fig. B3-4). When the engine is operating the sensor plate is deflected into the air cone; the deflection being dependent upon the volume of air passing through the cone (i.e. throttle plate opening). The air deflects the sensor plate until a state of hydraulic balance exists. This being due to the force of air pressure acting across the air sensor plate area and the primary fuel pressure acting over the control piston area.

The weight of the air sensor plate and connecting lever are balanced by a counterweight on the fuel distributor side of the lever.

Movement of the control piston and its horizontal control edge (see fig. B3-8) either increases or decreases the open area of the eight metering slits (one for each engine cylinder) in the fuel distributor.

Differential pressure valves (one for each cylinder) located within the fuel distributor, maintain a constant pressure drop across the metering slits.

Since the air flow sensor plate and the control piston are operated by the same lever, the rate of basic fuel discharge is proportional to the deflection of the air sensor plate within the calibrated cone as governed by throttle plate opening.

Idle CO (idle mixture strength) is adjusted at the engine idle speed setting during manufacture. Adjustment is achieved by removing a blanking plug and rotating the idle mixture screw. The blanking plug is then replaced and no further mixture adjustment should be necessary.

This basic adjustment alters the relationship of the air flow sensor plate position to the control piston in the barrel of the fuel distributor.

Fuel circuits

Fuel pressures within the KE2-Jetronic fuel circuit are as follows.

Primary pressure	5,7 bar to 5,9 bar (82.65 lbf/in ² to 85.55 lbf/in ²)
Differential pressure valves (lower chambers)	5,2 bar to 5,4 bar (75.4 lbf/in ² to 78.3 lbf/in ²)
Fuel injector pressure	3,8 bar to 4,0 bar (55.1 lbf/in ² to 58.0 lbf/in ²)

Primary fuel circuit

Primary fuel pressure is controlled by the fuel pressure regulator (see figs. B3-4 and B3-9).

Fuel is supplied to the fuel distributor from the main filter line and enters the centre chamber of the barrel.

Movement of the control piston within the barrel allows metered fuel to pass through the fuel distributor slits, to the upper side of the diaphragm in each differential pressure valve (see fig. B3-5).

The fuel entering the upper chamber of a differential pressure valve, deflects the diaphragm away from the open end of the injector fuel line and thereby allows fuel to flow to the injector.

The fuel injectors have an opening pressure of between 3,8 bar and 4,0 bar (55.1 lbf/in² and 58.0 lbf/in²) and are designed to spray finely atomized fuel under all operating conditions.

The primary fuel circuit also feeds fuel to provide the hydraulic force that is applied above the control

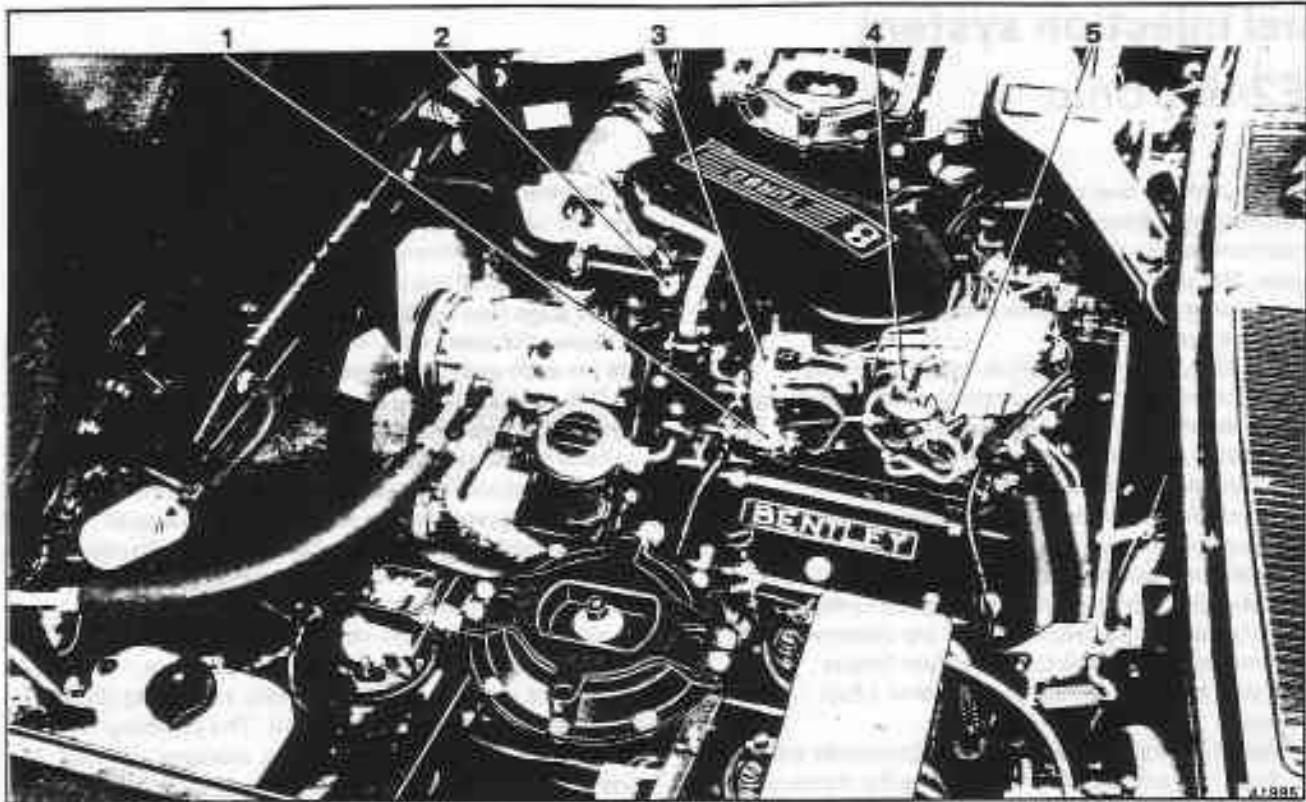

Fig. B3-1 Engine compartment details

- | | |
|-------------------------------|--------------------------------|
| 1 Idle speed control solenoid | 6 Air intake |
| 2 Thermostat housing outlet | 7 Air meter |
| 3 Auxiliary air valve | 8 Fuel distributor |
| 4 Fuel pressure regulator | 9 Fuel injection control relay |
| 5 Electro-hydraulic actuator | 10 Air pressure transducer |

piston. This provides the balancing force for the air load acting on the air sensor plate.

Primary fuel pressure is supplied to the cold start injector and to the EHA.

When the engine is stopped, the fuel pressure regulator allows system pressure to drop rapidly to a pressure governed by the fuel accumulator. This is just below fuel injector opening pressure.

The retention of the fuel at this pressure during 'hot soak' conditions prevents fuel vaporization and subsequent 'hot starting' difficulties.

A sudden drop in fuel pressure when the engine stops prevents dieseling (the tendency of an engine to continue 'running-on' after the ignition has been switched off).

Fuel distribution

Fuel is distributed uniformly to the cylinders via an accurately machined control piston and barrel assembly (see figs. B3-4 and B3-8). This assembly operates by controlling the open cross sectional area of the metering slits machined in the barrel.

The barrel has one rectangular metering slit for each cylinder.

Depending upon the position of the piston in the barrel, the metering slits are opened a corresponding amount. This allows fuel to flow through the openings to the differential pressure valves.

Each metering slit has a differential pressure valve.

If the air flow sensor plate travel is small, the control piston will only be raised in the barrel a small amount. This only allows a small section of the metering slits to be opened for the passage of fuel.

A hydraulic force is applied on top of the control piston and acts in opposition to the movement of the air flow sensor plate, lever, and control piston. A constant air/fuel pressure drop at the sensor plate is the result. This ensures that the control piston always follows the movement of the sensor plate lever.

A spring is fitted to assist the hydraulic force. It prevents the control piston being drawn upwards in the barrel due to a vacuum effect when the engine is stopped and the system cools down. If the control piston was drawn up in the barrel it could cause an excessively rich mixture when the engine is started again.

When the engine is switched off, the control piston sinks until it rests on the axial sealing ring. This position is set during manufacture and ensures complete closure of the metering slits when the piston is in the rest (zero lift) position. When the piston is resting on the sealing ring and the engine is switched off, the seal prevents primary system fuel leakage past the piston. This would otherwise allow fuel accumulator pressure to be lost too quickly.

Differential pressure valves

There is a differential pressure valve for each engine cylinder (see figs. B3-4 and B3-5).

These valves are a diaphragm type consisting of an upper and lower chamber with the diaphragm separating the two halves (see fig. B3-5).

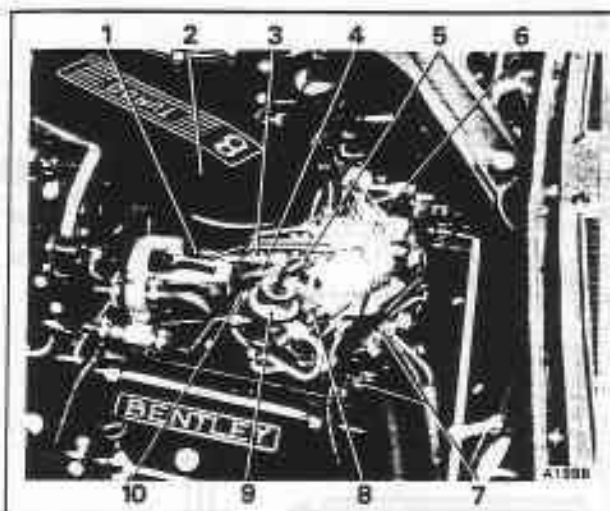

Fig. B3-2 Mixture control unit

- 1 Air meter
- 2 Air intake
- 3 Fuel supply to distributor
- 4 Fuel return to tank via pressure regulator
- 5 Fuel feed to cold start injector
- 6 Injector pipe
- 7 Hydraulic system pipes
- 8 Electro-hydraulic actuator
- 9 System pressure regulator
- 10 Fuel feed to pressure regulator

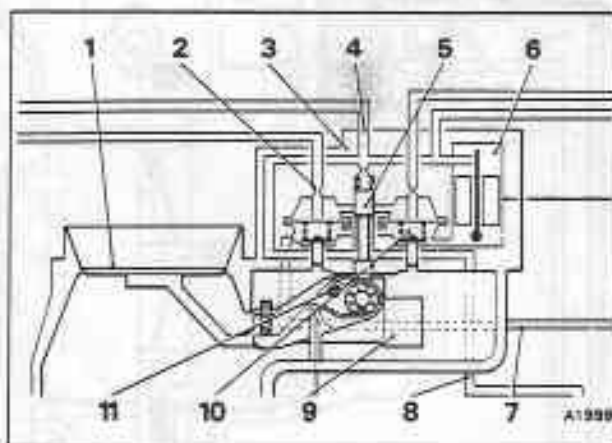

Fig. B3-3 Air flow sensor and fuel distributor (mixture control unit)

- 1 Air flow sensor plate
- 2 Fuel line to injector
- 3 Fuel distributor
- 4 Fuel line to cold start injector
- 5 Control piston
- 6 Electro-hydraulic actuator (EHA)
- 7 Fuel return line to pressure regulator
- 8 Fuel supply line
- 9 Counterbalance weight
- 10 Differential pressure valve
- 11 Pivot

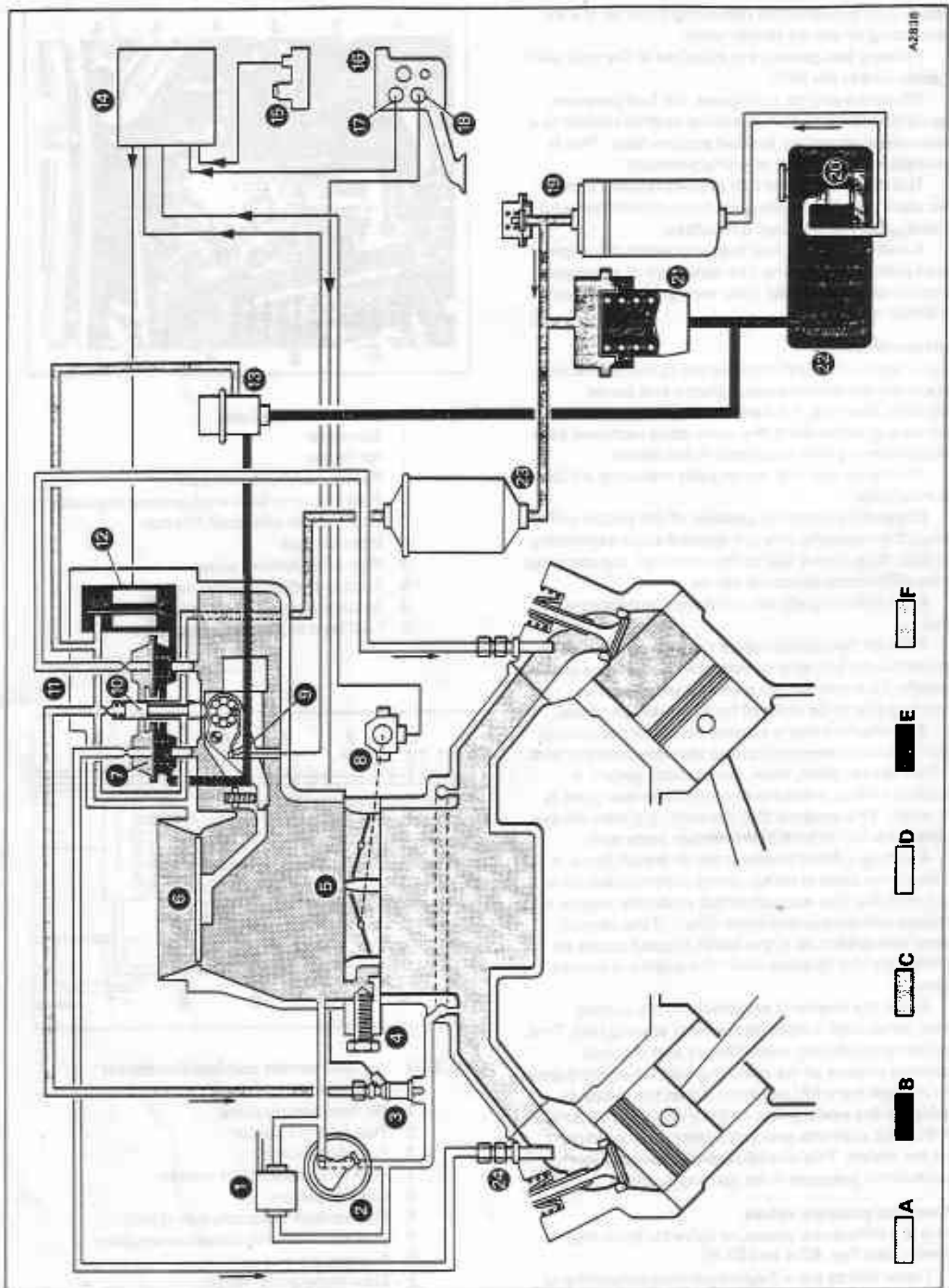

Fig. B3-4 Fuel injection system

Key to fig. B3-4 Fuel injection system

- 1 Idle speed control solenoid
 - 2 Auxiliary air valve
 - 3 Cold start injector
 - 4 Idle speed adjusting screw
 - 5 Throttle body
 - 6 Air flow sensor plate
 - 7 Differential pressure valve
 - 8 Throttle position switch
 - 9 Air flow sensor potentiometer
 - 10 Control piston
 - 11 Fuel distributor
 - 12 Electro-hydraulic actuator (EHA)
 - 13 Fuel pressure regulator
 - 14 Electronic control unit (ECU)
 - 15 Air pressure transducer (APT)
 - 16 Thermostat housing
 - 17 Temperature sensor
 - 18 Thermal time switch
 - 19 Fuel pump and pressure damper
 - 20 Fuel pre-pump
 - 21 Fuel accumulator
 - 22 Fuel tank
 - 23 Fuel filter
 - 24 Injector
- A Upper chamber pressure
 B Lower chamber pressure
 C Primary circuit pressure
 D Injection pressure
 E Unpressurized return line
 F Pre-pump pressure

The purpose of these valves is to maintain a given pressure drop at the metering slits. The pressure differential between the two halves of the valve is maintained irrespective of the fuel flow.

The difference in fuel pressure between the upper and lower chambers (and therefore the metering slits) is approximately 0,2 bar (3 lbf/in²). It is determined by the helical spring and the EHA operating in the lower chamber of each valve.

The lower chambers are connected to one another by a ring main.

The upper chambers are completely sealed from one another but are connected to the metering slits. Each chamber contains a valve seat and is connected to its respective injector line.

If an increased fuel flow enters the upper chambers, the pressure is increased and the diaphragms are deflected downwards. This opens the outlet end of the injector lines allowing the fuel flow to increase until the preset differential pressure is restored.

If the fuel flow decreases, the pressure in the upper chambers will fall allowing the diaphragms to lift. This reduces the fuel flow to the injectors until the pressure differential again prevails.

The total travel of the diaphragm is only a few hundredths of a millimetre.

An additional fuel filter incorporating a separator for ferromagnetic contamination is fitted in the fuel line to the EHA.

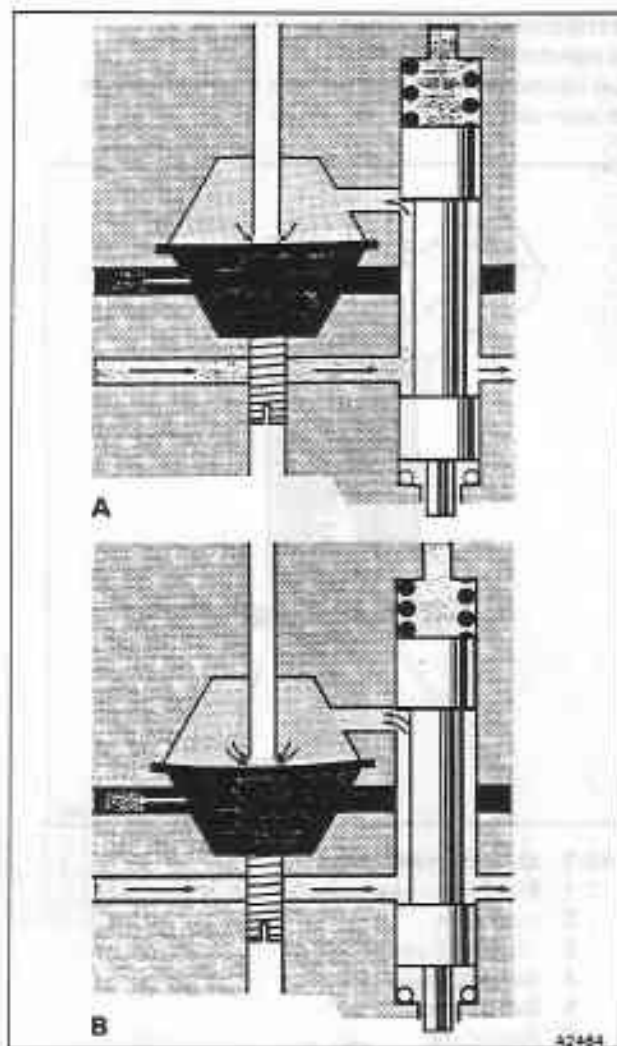

Fig. B3-5 Differential pressure valve

- A Low flow rate
 B High flow rate

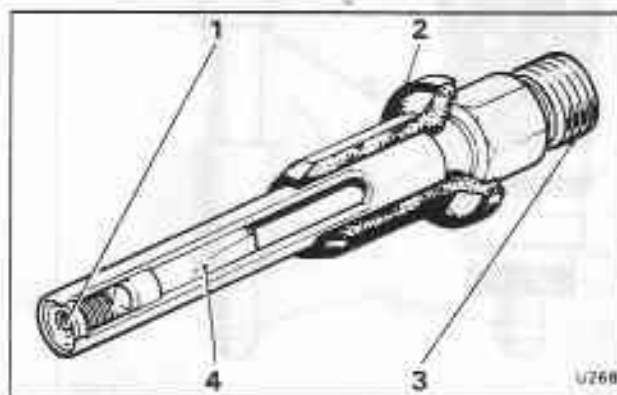

Fig. B3-6 Injector valve

- 1 Nozzle
- 2 Insulating sleeve
- 3 Fuel supply connection
- 4 Filter



Description of components

Fuel injector (see fig. B3-6)

A fuel injector is fitted into the inlet port just behind each inlet valve.

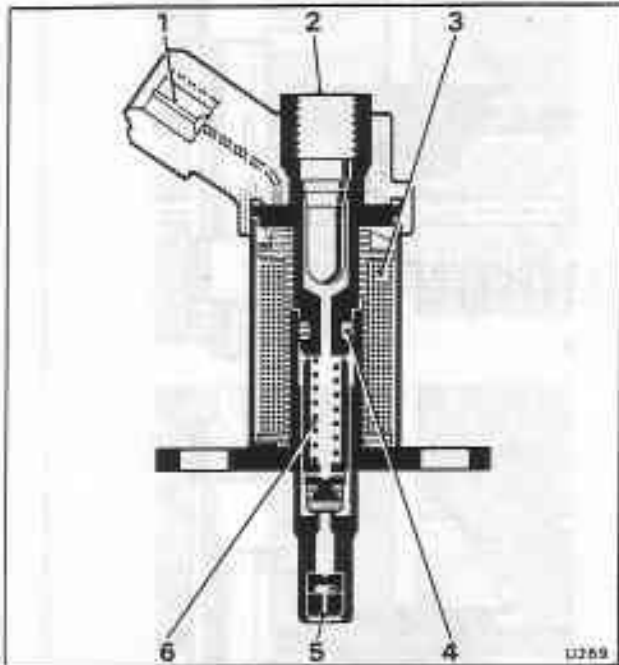

Fig. B3-7 Cold start injector

- 1 Electrical connection
- 2 Fuel inlet
- 3 Magnetic coil
- 4 Sealing ring
- 5 Swirl nozzle
- 6 Armature

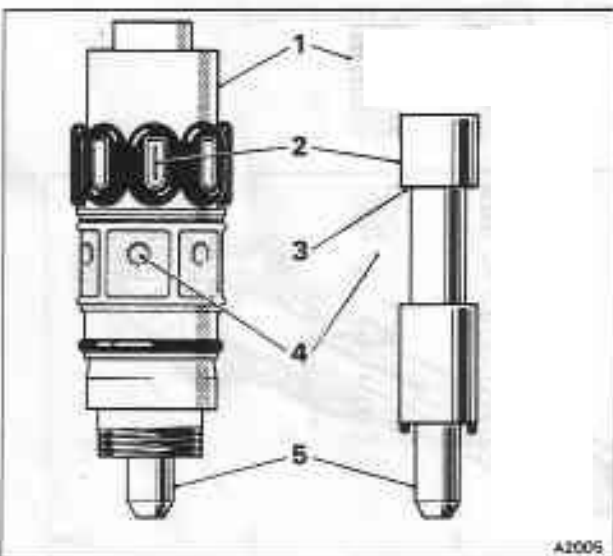

Fig. B3-8 Fuel distributor barrel and control piston

- 1 Fuel distributor barrel
- 2 Fuel metering slits
- 3 Piston control edge
- 4 Fuel inlet ports
- 5 Control piston

The injector opening pressure is between 3,8 bar and 4,0 bar (55.1 lbf/in² and 58.0 lbf/in²). It has no metering functions, its purpose being to continually spray finely atomized fuel under all running conditions.

The injector is supported in a specially moulded rubber sleeve. It is pressed (not screwed) into position. The hexagonal section is provided to hold the injector while the fuel line is attached.

A retention plate is fitted over the injector and secured by two small setscrews, each plate retaining two injectors.

Cold start injector (see fig. B3-7)

To facilitate engine starting when the coolant temperature is 35°C (95°F) or below, a cold start injector is fitted into the induction manifold. It sprays additional finely atomized fuel during engine cranking.

A thermal time switch mounted in the thermostat housing controls the operation of the injector.

Dependent upon coolant temperature the cold start injector ceases to operate when either the ignition key is released from the START position or if the engine fails to start within a period of up to a maximum of 8 seconds.

The cold start injector incorporates a helical spring which presses a moveable armature and seal against the valve seat, closing the fuel inlet. When the armature is energized (and therefore drawn upwards) the fuel port is opened and the pressurized fuel flows along the sides of the armature to the swirl nozzle.

Air flow sensor plate (see fig. B3-3)

The sensor plate is housed in the cone of the air meter. Its function is described on page B3-1, under the heading of Air flow sensing.

Differential pressure valves (see fig. B3-5)

The differential pressure valves (one for each engine cylinder) are housed in the fuel distributor. Their function is described on page B3-3 under the heading of Differential pressure valves.

Fuel distributor (see fig. B3-3)

The fuel distributor forms part of the mixture control unit. Its function is described in the section relating to fuel distribution on page B3-3.

Control piston (see fig. B3-8)

This is a cylindrical plunger type of valve that moves vertically in the fuel distributor. It is operated by a lever connected to the air flow sensor plate.

A precision machined edge on the control piston uncovers the fuel metering slits in the fuel distributor barrel. This controls the amount of fuel injected into the engine cylinders.

Fuel pressure regulator (see fig. B3-9)

When the engine is operating primary fuel pressure is maintained by the fuel pressure regulator.

Fuel enters the regulator via the port on the

right-hand side. Fuel returning from the fuel distributor enters the regulator via the connection on the left-hand side. The fuel return line (to the tank) is situated at the bottom of the assembly.

The fuel pump generates pressure in the system which forces the regulator control diaphragm upwards. The pressure of the counter-spring forces the valve body to follow the diaphragm until it abuts a stop. This enables the pressure control function to commence.

The fuel returning from the fuel distributor (comprising the fuel flowing through the pressure actuator plus the control piston leakage) can now flow back through the open valve seat to the fuel tank, together with any excess fuel supplied.

When the engine is switched off, the fuel pump stops and the system pressure drops. The plate valve moves downwards pushing the valve body downwards against the force of the counter spring until the seal closes the return to the tank. The pressure in the system then falls rapidly to just below the injector valve opening pressure, with the result that the injectors close.

The system pressure then increases again to a value determined by the fuel accumulator.

Anti-suction spring

When the engine is switched off and starts to cool, it is possible for some fuel to vapourize. This can cause a depression above the control piston as the fuel condenses. The result being a tendency for the piston to be drawn upwards in the barrel by the vacuum effect. In these conditions an excessively rich mixture would be fed to the engine when it is again started.

To prevent this a spring is fitted into the fuel distributor above the control piston. The applied force of the spring on the piston, prevents it being drawn upwards in the barrel.

Air pressure transducer (APT) (see fig. B3-10)

The air pressure transducer monitors induction manifold pressure, primarily to provide information for the KE2-Jetronic fuel injection system ECU. The ECU will then compensate for positive induction manifold pressure.

The transducer also provides additional instantaneous boost pressure information for the knock sensing boost control system.

Idle speed adjustment screw (see fig. B3-11)

This adjustment screw allows limited adjustment of the engine idle speed.

Idle speed control solenoid (see fig. B3-11)

The transmission load associated with engaging any forward gear would normally cause the engine idle speed to decrease.

To compensate for this a solenoid valve is opened (energized) when the gear range lever is moved to select a forward gear. This allows intake air to by-pass the throttles and maintain the idle speed at the correct setting.

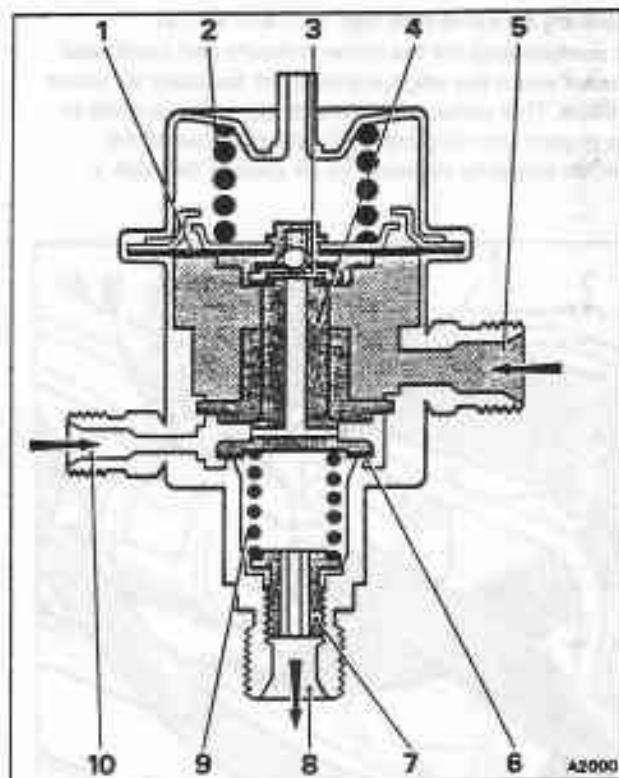

Fig. B3-9 System pressure regulator

- 1 Diaphragm
- 2 Control spring
- 3 Valve plate
- 4 Valve body
- 5 Inlet
- 6 Seal
- 7 Adjustment screw
- 8 To fuel tank
- 9 Counterspring
- 10 From fuel distributor

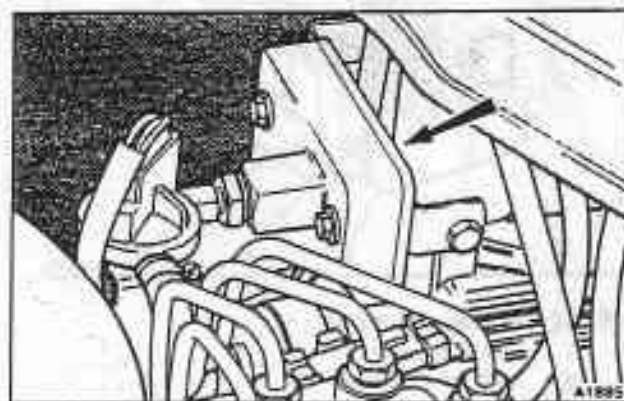

Fig. B3-10 Air pressure transducer

Note An uncorrected reduction in engine idle speed resulting from reverse gear being engaged for prolonged periods is not representative of normal engine operation.



Auxiliary air valve (see figs. B3-1 and B3-12)

To compensate for the richer mixture and increased friction when the engine is cold, an auxiliary air valve is fitted. This valve supplies a larger volume of air to the engine than is dictated by the position of the throttle butterfly valves. The air passes through a

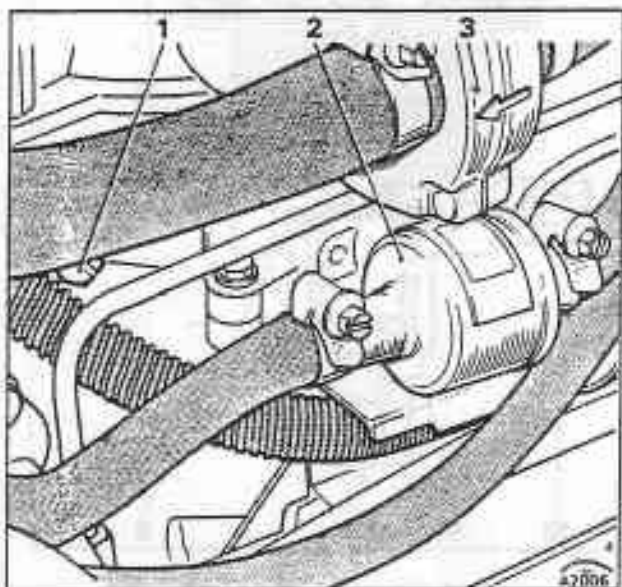

Fig. B3-11 Idle speed adjustment screw

- 1 Idle speed adjustment screw
- 2 Idle speed control solenoid
- 3 Auxiliary air valve

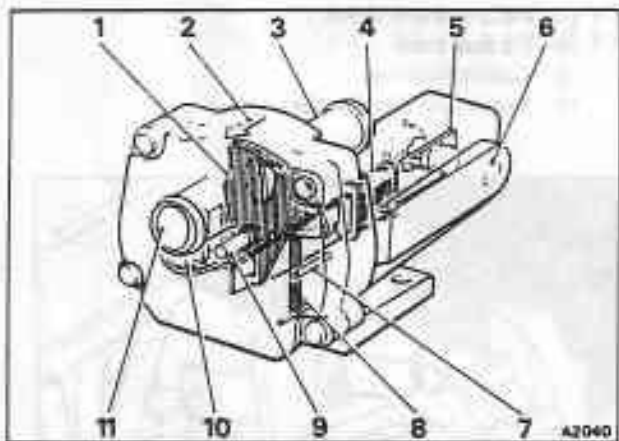

Fig. B3-12 Auxiliary air valve

- 1 Blocking plate
- 2 Airflow direction
- 3 Upstream throttle connection
- 4 Heating coil
- 5 Bi-metallic strip
- 6 Clamping pin
- 7 Blocking plate limit stop
- 8 Return spring
- 9 Pivot pin
- 10 Heating coil connection block
- 11 Downstream throttle connection

pivoted blocking plate orifice situated between the inlet and outlet connections of the valve. The movement of the blocking plate is dependent upon an electrically heated bi-metal strip.

When starting the engine the initial position of the blocking plate is determined by ambient temperature. However, as the bi-metal strip warms-up it progressively releases its force on the plate, allowing the return spring to pull the plate to the closed position. This gradually reduces the engine speed to the normal idle setting during the warm-up phase.

Thermal time switch (see fig. B3-13)

This switch limits the length of time that the cold start injector operates.

The switch is situated in the thermostat housing. It activates the cold start injector whenever the engine is being cranked and the coolant temperature is 35°C (95°F) or below. An electrically heated bi-metal inside the switch limits its operation to a maximum of 8 seconds dependent upon coolant temperature.

Coolant temperature sensor (see fig. B3-14)

The coolant temperature sensor is located in the thermostat housing and monitors engine coolant temperature.

When the engine is cold the internal resistance values of the sensor prompt the ECU to signal the EHA to provide the mixture enrichment necessary during the engine warm-up phase.

The coolant temperature sensor is also used to provide information for the EZ 58F digital ignition system.

Throttle position switch (see fig. B3-15)

This switch is mounted on the side of the throttle body on the primary throttle spindle.

The switch identifies idle, part load, and full load engine operation for the KE2-Jetronic and the EZ 58F ECU respectively.

Air flow sensor potentiometer (see fig. B3-16)

This assembly has three electrical pin connectors labelled 14, 17, and 18 in addition to a plastic location pin.

The potentiometer monitors the air flow by detecting the rate of air sensor plate movement. This enables the fuel injection system ECU to provide acceleration enrichment provided that the coolant temperature is 70°C (158°F) or below.

Under these conditions if the throttles are opened quickly, the air/fuel mixture is momentarily weakened and a short period of mixture enrichment is required, to ensure good transitional response.

The potentiometer is attached to the air flow sensor plate lever and reflects any change in the amount of metered air entering the induction system. The electrical signal generated within the potentiometer by the movement of the sensor plate, is then passed to the fuel injection ECU.

Any change necessary to the engine fuelling requirements is calculated by the ECU and a

corresponding signal is transmitted to the EHA, to momentarily richen the air/fuel mixture.

Electro-hydraulic actuator (EHA) (see fig. B3-19)
This assembly incorporates two polarity conscious electrical pin connectors in addition to a plastic location pin. The plastic location pin ensures that reversal of the pin connectors does not occur.

Depending upon the signals received from the ECU (i.e. information as to the operating conditions of the engine) the EHA varies the fuel flow to the lower chambers of the differential pressure valves.

An increase or decrease in the milliamps (mA) supply from the ECU to the EHA will result in a corresponding change in the fuel flow to the injectors and hence the CO concentration.

This alteration in mixture strength is not related directly to any mechanical air flow measurement.

KE2-Jetronic electronic control unit (ECU)
(see fig. B3-20)

This unit evaluates input data from various engine mounted sensors. With this information it generates a control signal in milliamps (mA) for the EHA. This provides electronic fuelling correction for start, post start, warm-up, acceleration enrichment, and positive induction manifold pressure compensations.

Increasing the mA supply to the EHA increases the exhaust CO concentration.

Modes of operation

The basic operation of this system is similar to the K-Jetronic system. However, the KE2-Jetronic system has the added refinement of electronic control over the air/fuel mixture.

The fuel injection system ECU evaluates the signals it receives from the various sensors. From this data it calculates the compensation instructions [in milliamps (mA)] for the EHA. It then conveys this information to the actuator via a 2-way plug.

Increasing the mA compensation to the EHA increases the exhaust CO concentration (i.e. it reduces the air/fuel ratio thus enriching the mixture).

The mA correction for the various engine operating modes are as follows.

Basic compensation

With the engine coolant temperature at 80°C (176°F) or above, the EHA is supplied with a basic compensation value of between 5.5 mA and 6.5 mA.

Correct idle mixture strength (CO setting) is achieved with the mechanical adjustment to the fuel mixture control unit and the basic mA compensation.

Start enrichment

Under all starting conditions, irrespective of engine coolant temperature, a start enrichment pulse valve of 150 mA for a duration of 1.5 seconds is provided.

Under most cold starting/ambient temperatures this start enrichment pulse will overlap from engine start to engine run modes. It will override all other enrichment factors for the 1.5 seconds duration.

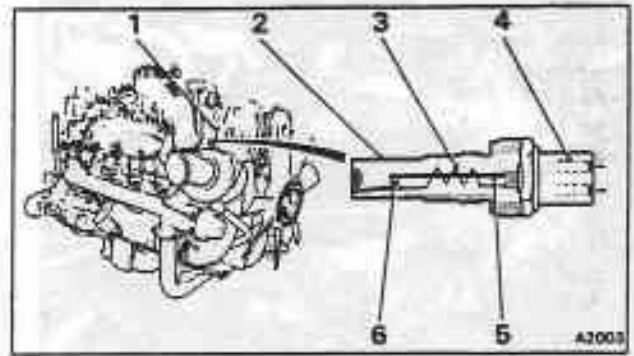

Fig. B3-13 Thermal time switch
1 Thermostat housing outlet
2 Housing
3 Heating coil
4 Plug connector
5 Bi-metallic strip
6 Contacts

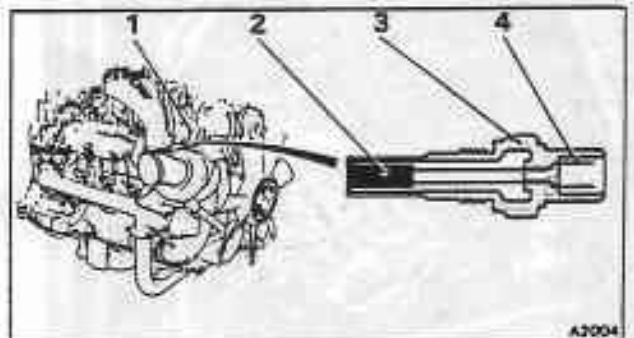

Fig. B3-14 Coolant temperature sensor
1 Thermostat housing outlet
2 Resistor
3 Housing
4 Plug connector

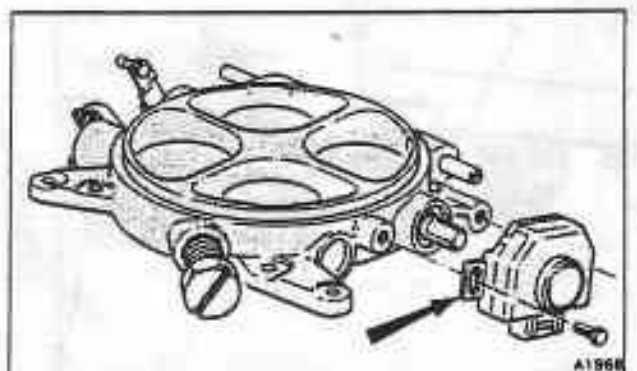

Fig. B3-15 Throttle position switch

After start enrichment

Following engine start, an after start enrichment feature is present for approximately 10 seconds. This is to assist engine running, primarily during fuel



Fig. B3-16 Air flow sensor potentiometer



Fig. B3-17 Electro-hydraulic actuator

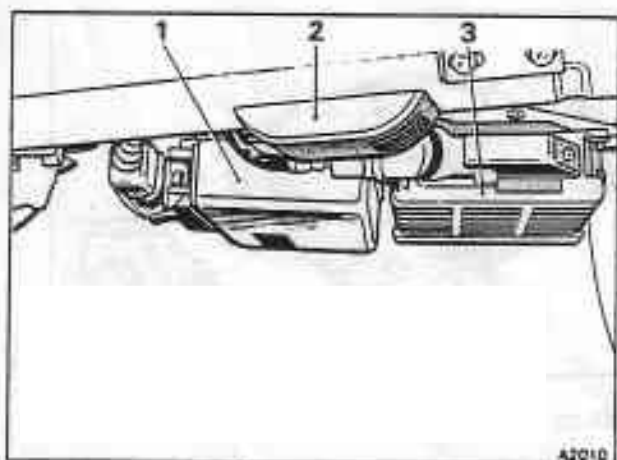

Fig. B3-18 Electronic control unit (ECU) – right-hand footwell

- 1 Ignition system ECU
- 2 Knee roll sensor (left-hand drive cars)
- 3 Fuel injection system ECU

injector stabilization. The after start mA compensation value is coolant temperature dependent and is in addition to the warm-up and basic compensation values.

An example of this is given after this section and a service graph is provided in the system checking procedure.

Warm-up enrichment

This feature is solely coolant temperature dependent and is in addition to the after start and basic compensation.

An example of this is given after this section and a service graph is provided in the system checking procedure.

Acceleration enrichment

During the warm-up phase acceleration enrichment is present dependent upon the rate of air flow sensor plate movement, until a coolant temperature of 70°C (158°F) is exceeded.

Enrichment takes the form of mA compensation. It is added to all other warm-up and after start features except start enrichment.

Once the maximum rate of air sensor plate movement has been reached, an increase in mA corresponding to acceleration enrichment reaches its peak value and fades away within one second.

Examples

Examples of cold start and warm start are as follows. The information is taken from the graphs provided in the system checking procedure.

Cold start

- 1 Cold Start at -10°C (14°F)
Start enrichment = 150 mA for 1.5 seconds
- 2 Engine starts
After start enrichment = 29 mA
Warm-up enrichment = 39 mA
Basic compensation = 6 mA

Total	74 mA
-------	-------

- 3 Approximately 10 seconds after starting
After start enrichment = ceases
Warm-up enrichment = 39 mA
Basic compensation = 6 mA

Total	45 mA
-------	-------

Warm start

- 1 Warm start at above 80°C (176°F)
Start enrichment = 150 mA for 1.5 seconds
- 2 Engine starts
After start enrichment = Nil
Warm-up enrichment = Nil
Basic compensation = 6 mA

Total	6 mA
-------	------

Engine speed limiting

A feature of the KE2-Jetronic fuel injection system, is that it limits the maximum speed of the engine. This it achieves by the ECU intermittently reversing the pin polarity of the EHA.

At a maximum engine speed of between 4500 rev/min and 4700 rev/min, the ECU intermittently reverses the current flow through the EHA. Whilst the current is reversed, the EHA drops the fuel pressure in the differential pressure valves which results in the valve diaphragms closing the injector line outlets.

The overall effect, is that the maximum speed of the engine is limited by the injectors only spraying fuel intermittently.

Electronic components

The theoretical wiring diagram (see fig. B3-19) provides basic details of the electrical components within the fuel injection system.

The description of the circuit provides service personnel with the basic knowledge necessary to identify the possible areas of faults.

Electrical feeds to the engine running sensor (item 5) are from the starter along the brown/black cable, from the fuel injection fuse (item 4) along the pink cable, and from the ignition fuse (item 6) along the white cable. The assembly senses whether the engine is stationary, cranking, or running.

The white cable also feeds the fuel injection relay windings (item 7), so that whenever the ignition is switched on the relay is energized. A 12 volts feed is then allowed along the brown cable, through the fuse and relay, to the white/purple cable on terminal 1 of the electronic control unit (item 10).

The electro-hydraulic actuator (item 8) and the air sensor potentiometer (item 9) are powered by and feed information to the electronic control unit along their respective colour coded cables.

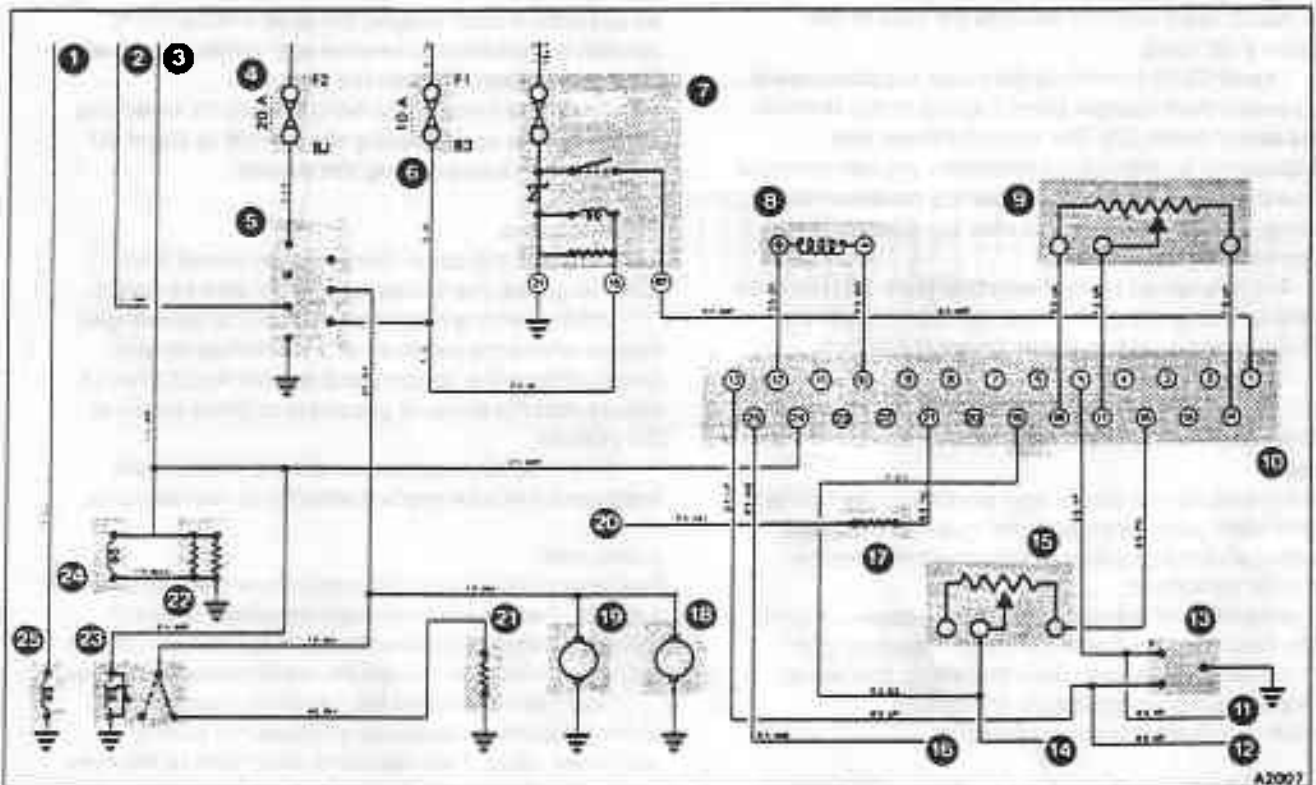

Fig. B3-19 Theoretical wiring diagram

- | | | | |
|----|---------------------------------------------------|----|---------------------------------------|
| 1 | From gearchange actuator | 13 | Throttle position switch |
| 2 | From starter | 14 | To knock sensor ECU |
| 3 | From gearchange actuator | 15 | Air pressure transducer |
| 4 | Fuel injection fuse | 16 | To ignition system ECU (engine speed) |
| 5 | Engine running sensor | 17 | Coolant temperature sensor |
| 6 | Ignition fuse | 18 | Fuel pump |
| 7 | Fuel injection control relay (with integral fuse) | 19 | Fuel pre-pump |
| 8 | Electro-hydraulic actuator | 20 | To ignition system ECU |
| 9 | Air flow sensor potentiometer | 21 | Auxiliary air valve heater |
| 10 | Electronic control unit | 22 | Thermal time switch |
| 11 | To ignition system ECU | 23 | Inhibit relay |
| 12 | To ignition system ECU | 24 | Cold start injector |
| | | 25 | Idle speed control solenoid |



A similar situation applies to both the air pressure transducer (item 15) and the throttle position switch (item 13). Both components exchange electrical information with the electronic control unit along their respective cables. However, these two components are also involved in the operation and control of the boost control system (knock sensing) and the ignition system (timing mapping).

The coolant temperature sensor (item 17) is a variable resistance. Therefore, as the coolant temperature increases, it alters the value of the electrical signal transmitted to the electronic control unit. The ignition system is also affected by this sensor.

The main fuel pump (item 18) and the pre-pump (item 19) are both energized along the white/pink cable from the engine running sensor.

The auxiliary air valve (item 21) is also fed by the white/pink cable, through the heater inhibit relay (item 23), and along the white/yellow cable. However, during engine cranking, the white/red cable energizes the inhibit relay which interrupts the feed to the auxiliary air valve.

The white/red cranking feed also supplies power to the cold start injector (item 24) and to the thermal time switch (item 22). The earth for these two components is interrupted whenever the temperature of the thermal time switch is above a predetermined setting. This cranking feed is also supplied to the electronic control unit.

The idle speed control solenoid (item 25) receives its signal along the green/blue cable whenever the gearchange actuator is in any forward position.

Workshop safety precautions

General

Always ensure that the vehicle parking brake is firmly applied, the gear range selector lever is in the park position and the gearbox isolator fuse is removed from the fuseboard.

A number of the nuts, bolts, and setscrews used in the fuel injection system are dimensioned to the metric system, it is important therefore, that when new parts become necessary the correct replacements are obtained and fitted.

Additional information when working on the KE2-Jetronic system

1. Do not start the engine unless the battery connections are securely fastened.
2. Do not disconnect the battery from the vehicle electrical system when the engine is running.
3. Do not charge the battery whilst it is installed in the vehicle.
4. Always remove the KE2-Jetronic ECU before carrying out any electrical welding work.
5. Always ensure that all wiring harness plugs are securely connected.
6. Do not disconnect or connect the wiring harness 25-way multiple plug of the KE2-Jetronic ECU with the ignition switched on.

Fire

Fuel is highly flammable, therefore great care must be exercised whenever the fuel system is opened (i.e. pipes or unions disturbed) or the fuel is drained. Always ensure that 'no smoking' signs and foam, dry powder, or CO₂ (carbon dioxide) fire extinguishers are placed in the vicinity of the vehicle.

Always ensure that the battery is disconnected before opening any fuel lines.

If the fuel is to be drained from the tank, ensure that it is siphoned into a suitable covered container.

Fuel pressure

The fuel injection system contains fuel that may be under high pressure approximately 5,7 bar to 5,9 bar (82.65 lbf/in² to 85.55 lbf/in²). Therefore, to reduce the risk of possible injury and fire, always ensure that the system is depressurized by one of the following methods before commencing any work that will entail opening the system.

- a. Clean the inlet connection to the fuel filter. Wrap an absorbent cloth around the joint and carefully slacken the pipe nut to release any pressurized fuel from the system. Tighten the pipe nut.
- b. Allow the pressure to fall naturally by switching off the engine and allowing the vehicle to stand for four hours before opening the system.

Exhaust gases

In addition to the usual dangers associated with exhaust gases, the following should also be noted.

Whenever it is necessary to run a turbocharged engine within the confines of a workshop for any length of time (i.e. to carry out certain tests), always ensure that the exhaust gases are suitably piped to the outside.

Under no circumstances should exhaust gas extraction units be applied directly to the tailpipes.

Health risk

Fuel may contain up to 5% of benzene as an anti-knock additive. Benzene is extremely injurious to health (being carcinogenic) therefore, all contact should be kept to an absolute minimum, particularly inhalation.

Fuel has a sufficient high vapour pressure to allow a hazardous build-up of vapour in poorly ventilated areas. Fuel vapour is an irritant to the eyes and lungs, if high concentrations are inhaled it may cause nausea, headache, and depression. Liquid fuel is an irritant to the eyes and skin and may cause dermatitis following prolonged or repeated contact.

When it becomes necessary to carry out work involving the risk of contact with fuel, particularly for prolonged periods, it is advisable to wear protective clothing including safety goggles, gloves, and aprons. Any work should be carried out in a well ventilated area.

If there is contact with fuel the following emergency treatment is advised.

Ingestion (swallowing)

Do not induce vomiting. Give the patient milk to drink

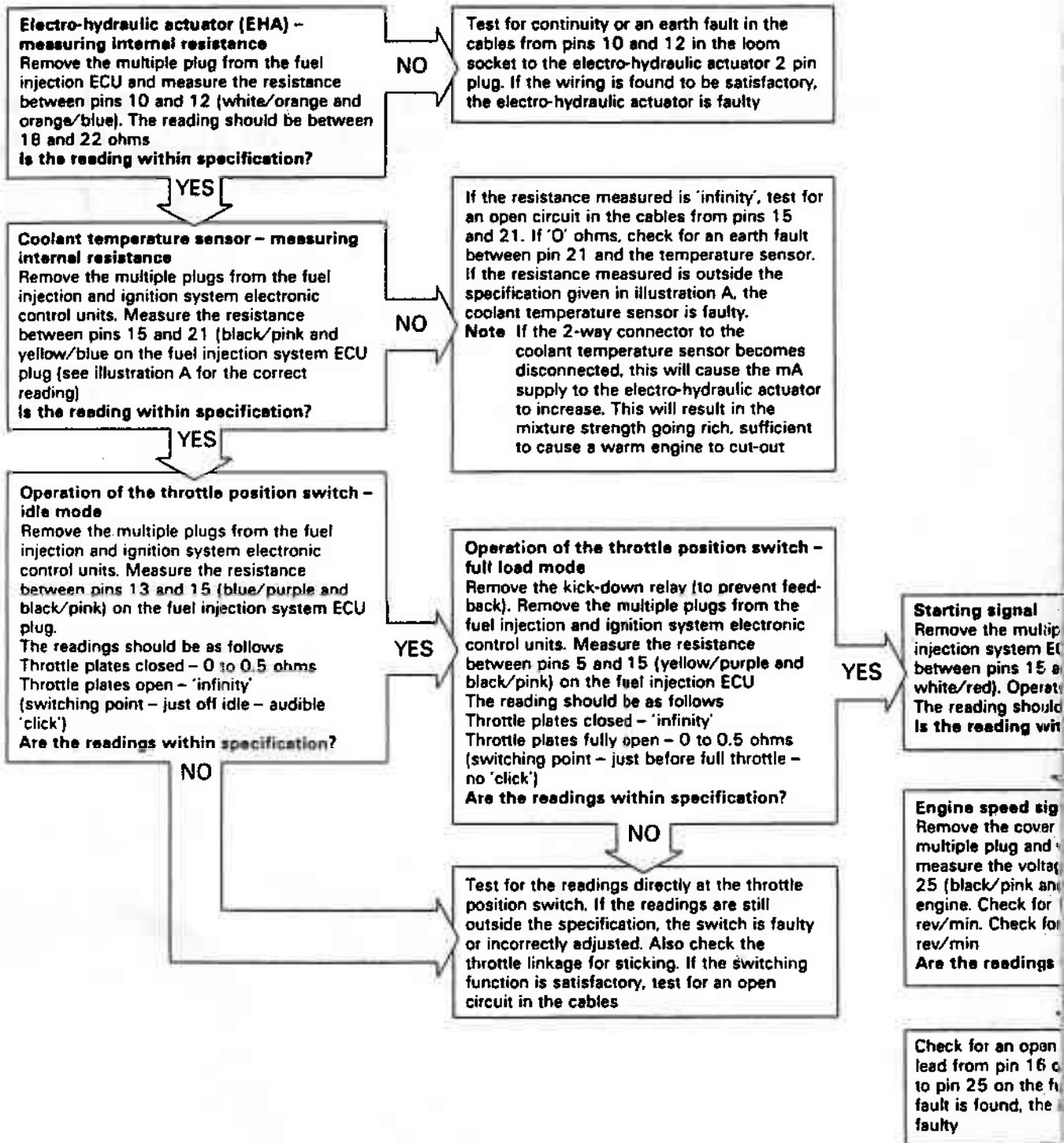

Figure B3-20

Fuel injection system – electrical test programme – fault diagnosis flow chart

Sheet 1 of 2

Bosch KE2-Jetronic fuel injection system electrical test programme



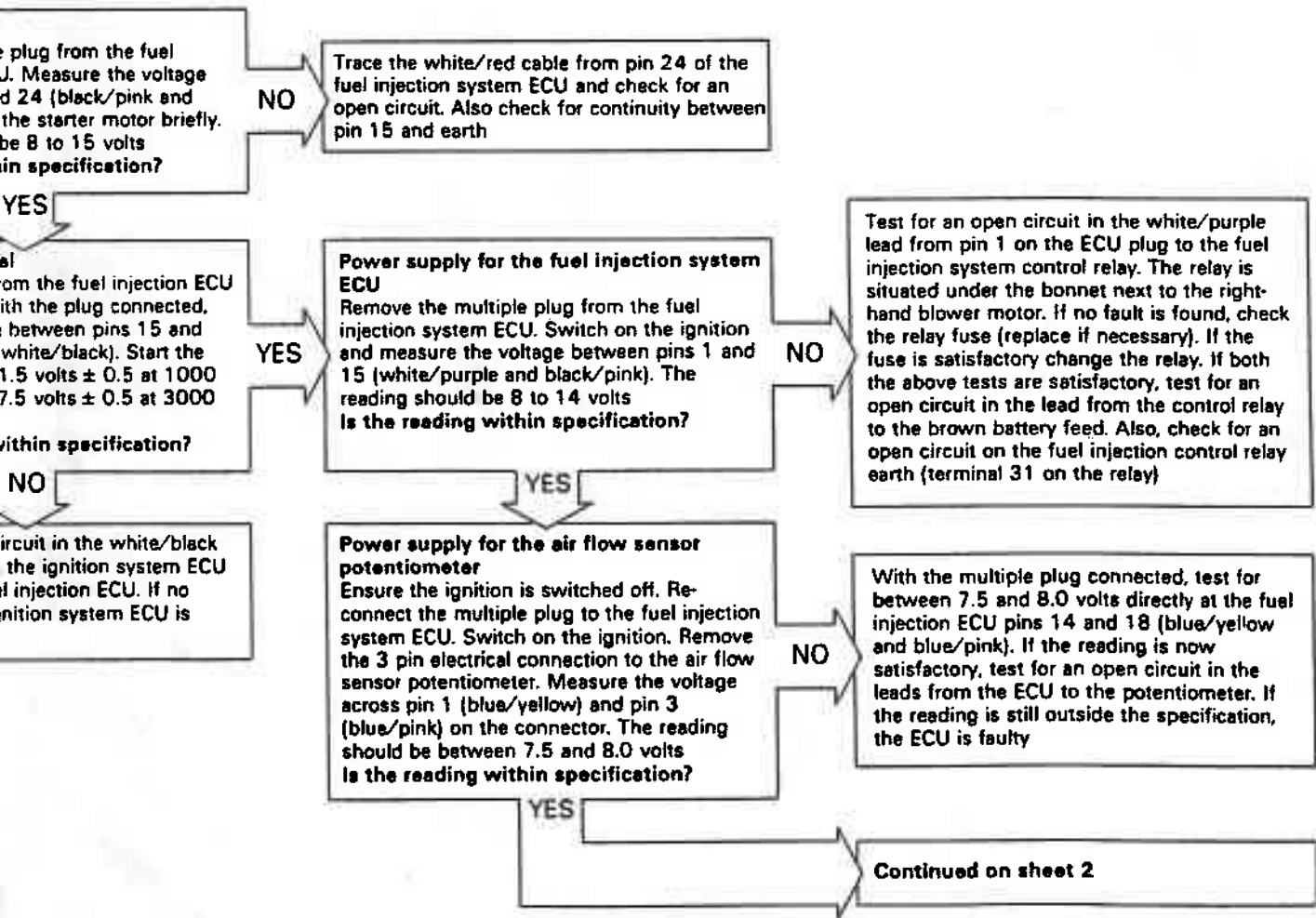
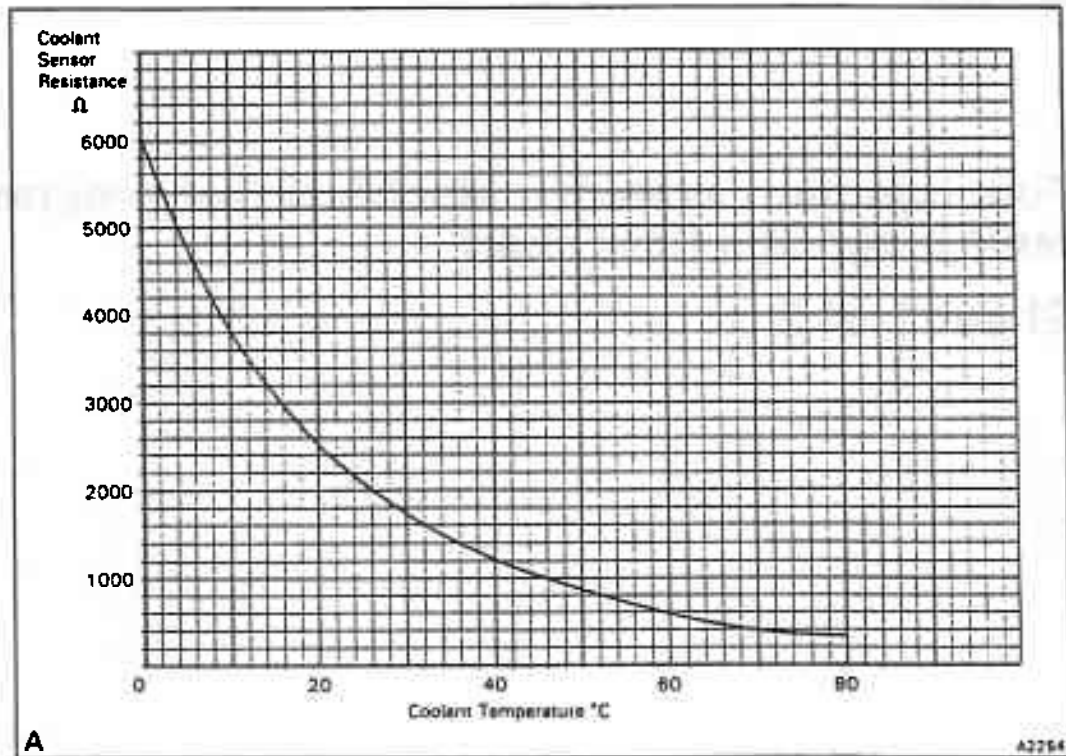



Figure B3-20

Fuel injection system – electrical test programme – fault diagnosis flow chart

Sheet 2 of 2

Continued from sheet 1

Signal from the air flow sensor potentiometer

Re-connect the multiple plug to the fuel injection ECU. Switch on the ignition. Re-connect the 3 pin connector to the air flow sensor potentiometer. Using probes, measure the voltage across pin 1 (blue/yellow) and pin 2 (blue/brown). With the air duct to the airmeter removed, depress the air flow sensor plate. The voltage reading should progressively increase from a baseline of zero volts (with increasing air sensor plate deflection) up to a maximum of between 7.5 and 8.0 volts. Is the reading within specification?

NO

YES

Test for an open circuit in the leads from the fuel injection ECU to the 3 pin potentiometer connector. If no fault is found, test the potentiometer for an open circuit directly at the 3 connection pins as follows. Remove the 3 pin connector from the potentiometer. With the ignition off, measure the resistance across the following leads

Cable colour	Sensor plate position	Resistance
Blue/yellow - blue/pink	Closed (idle)	4.2 to 4.4 k/ohms
Blue/brown - blue/pink	Closed (idle)	4.9 to 5.2 k/ohms
Blue/brown - blue/pink	Closed (idle)	4.9 to 5.2 k/ohms
Blue/yellow - blue/pink	Fully open	4.2 to 4.4 k/ohms
Blue/brown - blue/pink	Fully open	0.8 to 1.0 k/ohms

Are the readings within specification?

NO

If the readings are outside the specification, the fuel injection ECU is faulty.

YES

'Starting', 'Post start', and 'Warm-up' enrichment functions

Connect a digital multimeter (with a range of 0 to 150 milliamps) in series with the electro-hydraulic actuator using the adapter RH 9893 (see fig. B3-23). Whilst observing the multimeter, start the engine. The enrichment should initially peak at 150 mA for approximately 1.5 seconds and then progressively decay to $6 \text{ mA} \pm 0.5 \text{ mA}$ when the engine has reached its normal running temperature [80°C (176°F) coolant temperature]

YES

NO

Normal operating conditions - 'hot idle'
With the engine idling at 580 rev/min and a coolant temperature of 80°C (176°F) i.e. fully warmed-up, check that the milliamp supply to the electro-hydraulic actuator is $6 \text{ mA} \pm 0.5 \text{ mA}$. Is the reading within specification?

NO

If the reading is outside the given specification, (and all the preceding tests in this programme have been carried out), the fuel injection ECU is faulty. If no reading is obtained, check for an open circuit or an earth fault in the leads from pins 10 and 12 (white/orange and orange/yellow) on the fuel injection ECU to the electro-hydraulic actuator

YES

'Full load' correction

Ensure that the multiple plug to the fuel injection ECU is connected. Disconnect the 3-way electrical connection to the throttle position switch. Using a suitable piece of wire with the appropriate miniature 'TTS' type connectors, bridge the black and yellow/purple connections in the ECU side of the 3-way connector. The milliamp supply to the electro-hydraulic actuator will now be governed by the full load fuelling 'map' see illustration B for the correct specification. **Note** The engine must run above the idle speed setting for this test. Are the readings within specification?

YES

Boost pressure
Ensure that the fuel injection ECU is connected. Remove the 3 pin connector from the air pressure sensor. Measure the voltage across the 3 cables (see illustration B). The voltage should be $5 \text{ volts} \pm 0.5 \text{ volts}$. Is the reading within specification?

NO

Test for an open circuit in the leads from the 3-way electrical connector to the fuel injection ECU. If no fault is found, test for an open circuit in the white/black cable from pin 16 on the ignition system ECU to pin 25 on the fuel injection ECU. If no fault is found, the fuel system and/or the ignition system ECU is faulty

Check for 5 volts across the 3 cables to earth (do this with the engine running). If the voltage is outside the specification, the fuel injection ECU is faulty. Also, check for an open circuit in the white/black cable in the ignition system ECU.

are outside the given
potentiometer is faulty

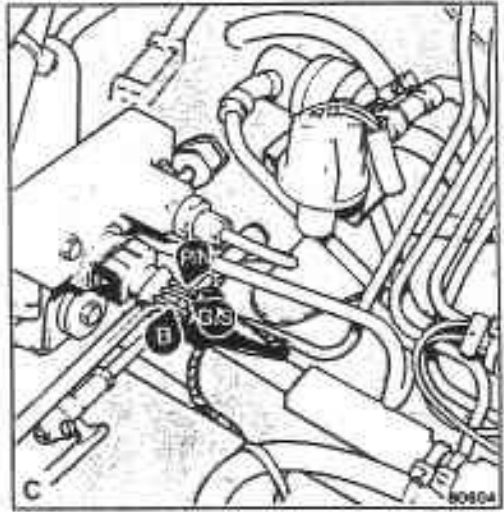
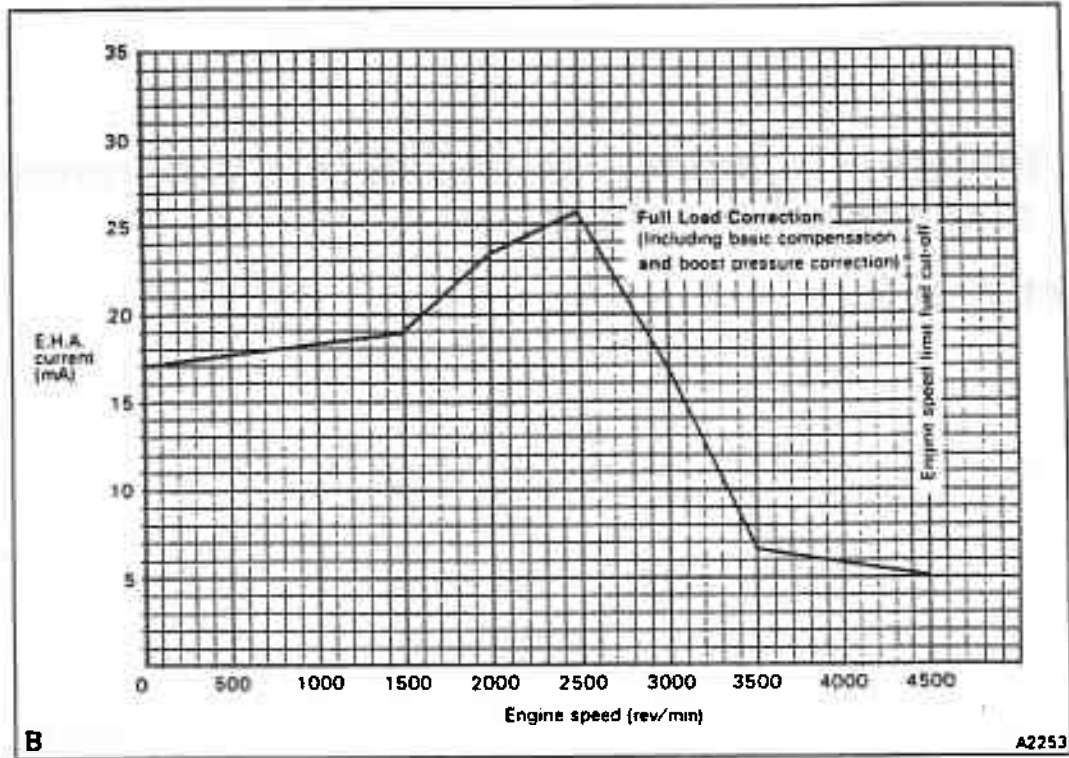

correction
multiple plug is connected to
ECU. Switch on the ignition.
in electrical connector from
transducer. Measure the
the purple/brown and black
stration C). The reading should
volts
within specification?

NO

± 0.5 vol: across pin 16
on the fuel injection ECU and
with the ECU plug connected).
now satisfactory, check for
between pin 16 (purple/
fuel injection ECU and pin 1
ure transducer connector.
h continuity of the black
pressure transducer connector

YES

Replace the 3 pin electrical connector and
measure the voltage across the green/slate
and black cables (see illustration C). The
reading should be 2.46 volts ± 0.5 volts
Is the reading within specification?

NO

Test for an open circuit in the green/slate
cable from pin 19 on the fuel injection ECU
to the air pressure transducer connector.
If the above is satisfactory, and there is no
blockage or restriction in the manifold to
transducer signal pipe, the air pressure
transducer is faulty

YES

Idle adjustment checks
Check the idle mixture strength and idle
speed. Refer to the Bosch KE2-Jetronic fuel
injection system – Engine tuning procedure

Tests complete