



# Fuel system

## Contents

### Sections

	Rolls-Royce		Corniche / Corniche II	Bentley	Mulsanne / Mulsanne S	Turbo R	Continental
	Silver Spirit	Silver Spur		Eight			
Contents and issue record sheet	C1	C1	C1	C1	C1	C1	C1
1987/88/89 model years Fuel system	C2	C2	C2	C2	C2	C2	C2



# Issue record sheet

The dates quoted below refer to the issue date of individual pages within this chapter.

Sections	C1	C2								
Page No.										
1	5/88	4/89								
2		5/88								
3	4/89	5/88								
4		5/88								
5		5/88								
6		10/88								
7		5/88								
8		10/88								
9										
10										
11										
12										
13										
14										
15										
16										
17										
18										
19										
20										
21										
22										
23										
24										
25										
26										
27										
28										
29										
30										
31										
32										
33										
34										
35										
36										
37										
38										
39										
40										
41										
42										
43										
44										
45										
46										
47										
48										
49										
50										
51										
52										
53										
54										



## Fuel system

The fuel system is of the recirculating type as shown in figure C2-1. Excess fuel not required by the engine is returned to the fuel tank.

For information relating to the fuel evaporative emission control system, refer to Chapter G.

### Depressurizing the fuel system

The fuel in the system may be pressurized, except for the fuel tank and return lines. Therefore, it is recommended that the fuel system be depressurized before dismantling any parts of the system.

To depressurize the system proceed as follows.

1. Clean the inlet connection to the fuel filter.
2. Wrap an absorbent cloth around the joint and carefully slacken the pipe nut to release any pressurized fuel from the system.
3. Tighten the pipe nut.
4. It should be noted that the system will still contain unpressurized fuel.
5. After working on the system, run the engine and check to ensure that there are no leaks.

### Water contamination of the fuel

If the fuel system becomes contaminated, it is recommended that the following procedure is adopted to remove the water.

1. Detach the fuel return pipe from either the fuel distributor (naturally aspirated cars) or the lower connection of the fuel pressure regulator (turbocharged cars).
2. Blow compressed air into the fuel return line to force any fuel into the tank.
3. Slightly jack-up the car on the right-hand side and siphon the fuel from the fuel tank. Lower the jack.
4. Pour 4.5 litres (1 imp gal, 1.2 US gal) of Exxonvarsol or Shell Mineral spirit 135 (white spirit) into the fuel tank and rock the car from side to side. This will thoroughly mix the spirit with any water remaining in the tank.
5. Slightly jack-up the car on the right-hand side and siphon the fuel tank. Lower the jack.
6. Repeat Operations 4 and 5 until all the water has been removed from the fuel tank.
7. Disconnect and insulate the electrical leads from the fuel tank pre-pump. Unscrew the worm drive clip securing the fuel feed hose and detach the hose.
8. Remove the locking ring from the base of the fuel tank using the special tool RH 9928. Withdraw the pre-pump assembly and discard the sealing ring.
9. Fit a new pre-pump assembly, noting the following.
  - a. Ensure that the pre-pump filter sock is not deformed in any way and ensure that the sock support spring is fitted.
  - b. Ensure that a new sealing ring is fitted.
  - c. Secure the assembly with the locking ring using

the special tool RH 9928.

- d. Ensure that the lug on the locking ring just contacts the stop on the tank outlet. Do not overtighten.
- e. Do not connect the electrical leads to the pre-pump (ensure that the leads are insulated).
10. Detach the hose from the main fuel pump inlet connection.
 

Connect a length of hose, approximately 2 m (6 ft) in length to the fuel pump inlet. Place the other end of the hose in a suitable clean container of at least 2,3 litres (4 imp pt, 4.8 US pt) capacity.
11. Connect another length of hose, approximately 2 m (6 ft) in length to the fuel distributor return pipe disconnected in Operation 1. Place the free end of the hose into an empty container of at least 5 litres (1.1 imp gal, 1.3 US gal) capacity.
12. Fit a new fuel filter assembly.
13. Remove the fuel injectors and fuel injection lines.
14. Remove the air intake ducting (refer to Chapter J).
15. Detach the electrical plug from the pressure control valve (if fitted).
16. Connect the eight auxiliary plastic fuel lines from the fuel delivery quantity comparison tester RH 9613 (Bosch No. KDJE 7455) to the fuel injection line connections on the fuel distributor. Place the free ends of the plastic fuel lines into the empty container.
17. Pour at least 2,3 litres (4 imp pt, 4.8 US pt) of mineral spirit into the container feeding the fuel pump.
18. Operate the main fuel pump (refer to the appropriate section within Chapter B). Do not allow the fuel pump to run dry.
19. Press the air flow sensor plate downwards to its maximum open position.
20. Continue to flush the system through until the mineral spirit runs clean.
21. Test the fuel injectors (refer to Chapter B).
22. Fit the fuel injectors and injector lines.
23. Fit a new fuel filter assembly.
24. Remove the two auxiliary hoses, refer to Operations 10 and 11.
25. Fit the fuel return pipe, refer to Operation 1.
26. Fit the hose from the fuel tank to the fuel pump inlet connection.
27. Connect the electrical leads to the fuel tank pre-pump.
28. Add fuel to the tank and test the engine.

### Removal and fitting of components

Before dismantling connections and removing components always depressurize the system. Ensure that any open connections are blanked off to prevent the ingress of dirt.

**Fuel tank** (see figs. C2-1 and C2-6)

The fuel tank is fitted at the forward end of the luggage



compartment behind the carpet covered sealing panel.

A small expansion tank having a capacity of approximately 3 litres (5.5 Imp pts, 7 US pts) is situated within the main fuel tank to inhibit complete filling. This provides fuel expansion volume to cope with extreme temperature conditions.

When the car is being filled with fuel, the main fuel tank (without an expansion tank) could normally be completely filled, leaving only the filler neck and vent connector pipes to accommodate the expansion of the fuel. Therefore, an expansion tank is situated in the upper part of the main fuel tank and as the fuel level rises above the lower part of the expansion tank it flows inside through two small holes in the base. Two additional holes in the top of the expansion tank allow air to escape.

#### Fuel tank – To remove

1. Carry out the necessary workshop safety precautions (refer to Chapter A).
2. Disconnect and remove the battery.
3. Siphon the fuel from the tank.
4. Unscrew the Pozidriv screws from the panel at the forward end of the luggage compartment and remove the knob from the battery master switch (if fitted).
5. Withdraw the panel to reveal the fuel tank. On 2 door cars, disconnect the electrical cables from the luggage compartment lamp and the centralized door locking switch.
6. Disconnect the three electrical cables from the fuel tank level gauge. Remove the tape securing the loom to the fuel tank.
7. Remove the clips securing the three fuel tank vent hoses to their respective connections on top of the tank.
8. Withdraw the hoses and blank the open connections.
9. Unscrew the worm drive clip securing the filler hose to the fuel tank. Free the hose and blank off the open connection.
10. From beneath the car, detach the fuel feed and return connections at the fuel tank. Blank off the open connections. Disconnect and insulate the electrical cables from the pre-pump.
11. Disconnect the rollover tube at the hose connection on the left-hand side of the fuel tank. Slacken the two tube retaining clips on the luggage compartment floor. Free the rollover tube from the Insulok plastic clip situated on either side of the tank.
12. Turn the rollover tube in the retaining clips so that

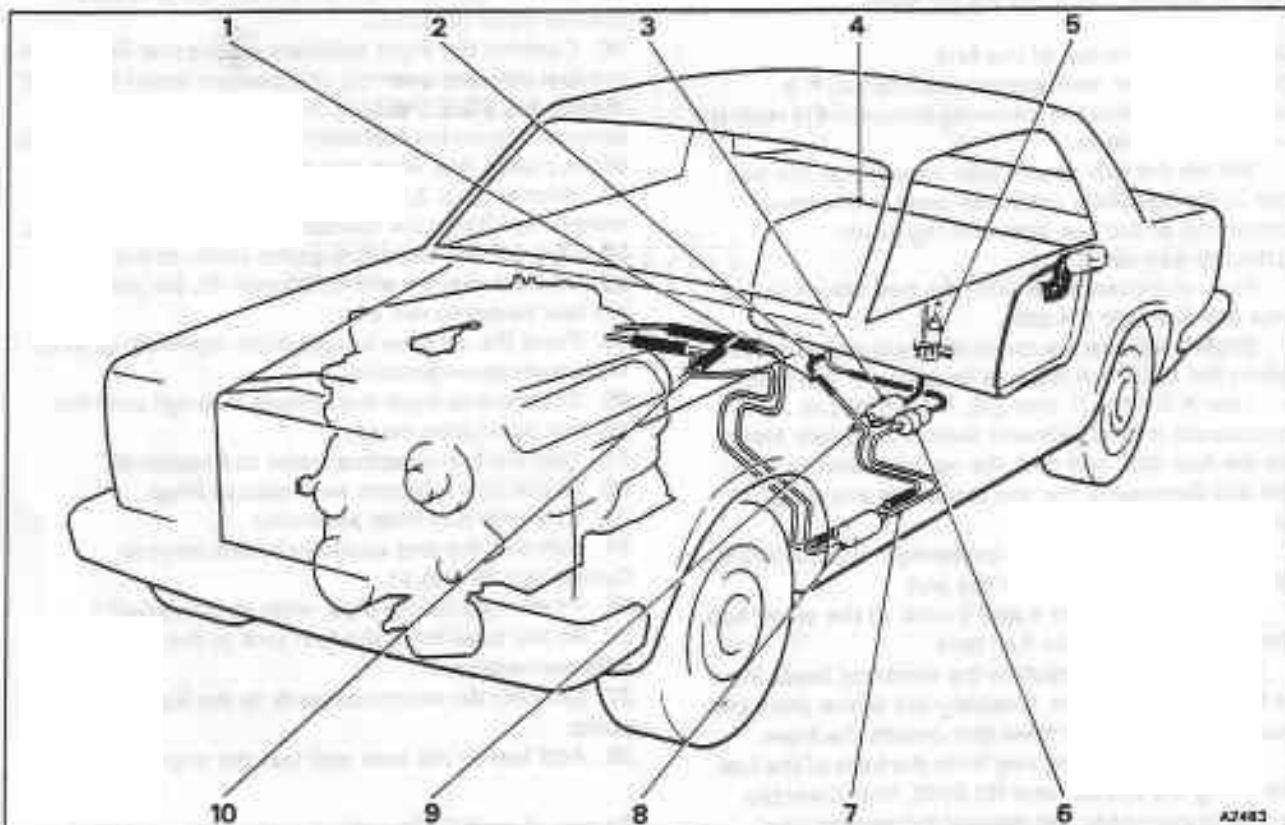

Fig. C2-1 Fuel system layout

- |                    |                        |
|--------------------|------------------------|
| 1 Non-return valve | 6 Fuel accumulator     |
| 2 Fuel return line | 7 Fuel supply line     |
| 3 Fuel pump        | 8 Fuel filter          |
| 4 Fuel tank        | 9 Fuel pressure damper |
| 5 In-tank pre-pump | 10 Fuel cooler         |

it lies on the luggage compartment floor.

13. Unlock and unscrew the half-nut from each of the tank retaining strap bolts.
14. Unscrew the full nut from each of the two tank retaining strap bolts.
15. Withdraw the bolts and the crossmember (if fitted). Collect the four bridge pieces from the ends of the retaining straps.
16. Bend the retaining straps and carefully withdraw the fuel tank assembly.

**Note** The fuel tank may prove difficult to move due to the bonding effect that can take place between the rubber mountings and the tank after a period of time.

If an extra effort is required to free the tank, ensure that it will not be damaged by the force used.

#### Fuel tank – To fit

1. Ensure that the battery is removed and the necessary workshop safety precautions carried out (refer to Chapter A).
2. Clean the forward area of the luggage compartment.

If blanking plugs, nuts, washers, etc., remain in this area when the fuel tank is fitted, they could become the cause of noise which may prove difficult to eradicate once the fuel tank is in position.

3. Fit the fuel tank cushioning pad to the rear seat panel.
4. Ensure that the rubber blanking grommets are fitted, one into each of the forward corners of the

luggage compartment floor.

5. Fit the rubber matting to the luggage compartment floor.
6. Fit the moulded rubber insulating pieces around the suspension pots and wheel arches.
7. Fit the two compriband pads around the large holes in the luggage compartment floor.
8. Fit the compriband covered wooden strip on the luggage compartment floor where it joins the rear seat panel.

**Note** The position of all pads and strips are illustrated in figures C2-2 and C2-3. All pads and strips should be secured in position using an appropriate adhesive (refer to TSD 4700, Chapter S).

9. Fit the fuel tank upper securing straps into position.
10. Fit the rollover tube, ensuring the uprights are turned to lie flat on the luggage compartment floor.
11. Ensure that the evaporative loss control hose (if fitted), is positioned correctly through the luggage compartment floor. Also, ensure that it is clipped above tank level in the left-hand luggage compartment hinge area.
12. Fit the long metal pipe and short hose across the top of the fuel tank, securing in position with clips.
13. Fit the fuel tank into position ensuring that the two bosses in the base of the assembly are positioned in the body holes.
14. Connect the vent hoses from both sides of the fuel tank to the filler assembly and tighten the retaining clips.

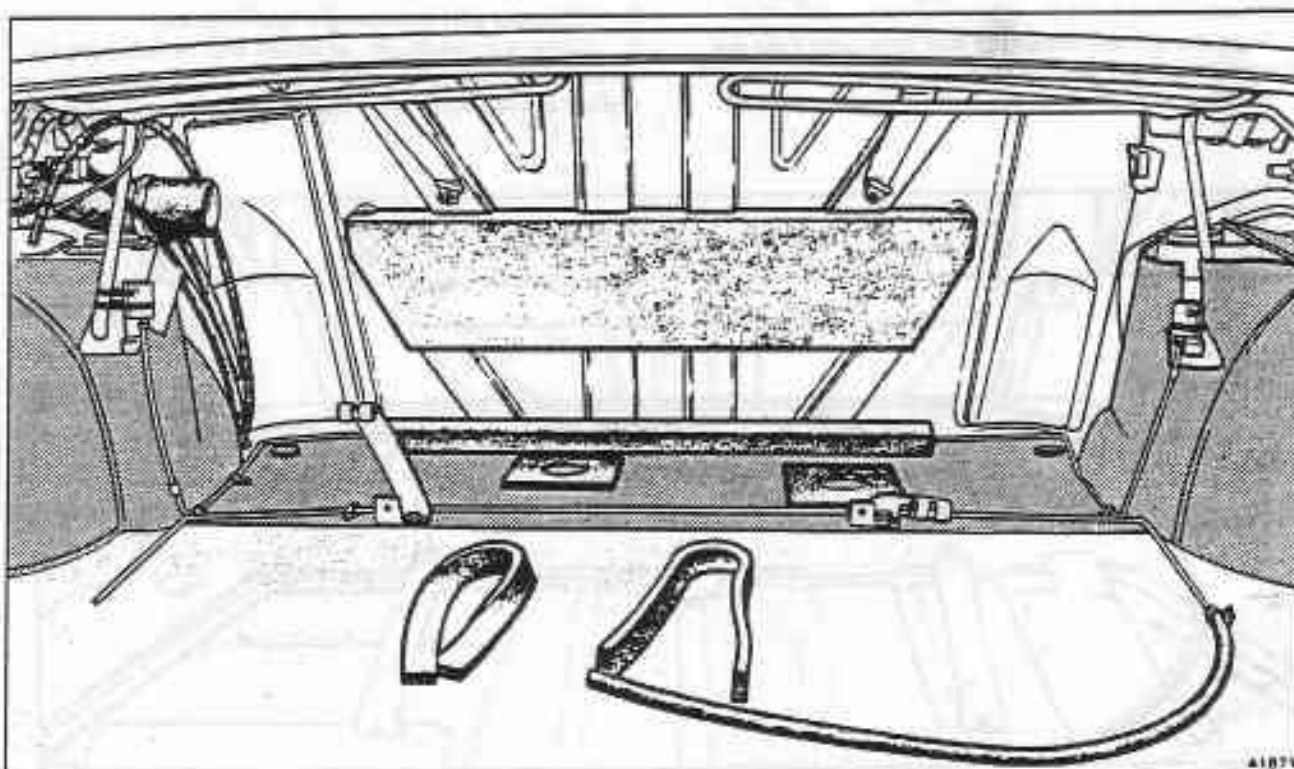

Fig. C2-2 Fuel tank mounting pads and straps (4 door cars)



15. Rotate the rollover tube into the upright position. Clip the tube to the hydraulic connector blocks on either side of the tank, using Insulok plastic clips.

16. Connect the hose that passes through the luggage compartment floor to the left-hand upright pipe. Connect the right-hand upright pipe via a hose to the centre vent connection on top of the fuel tank. Secure the hoses with retaining clips.

**Note** A restrictor is fitted into the right-hand hose which connects to the fuel tank centre vent.

On 4 door cars the right-hand hose is fitted into the rear quarter panel.

17. Fit the two lower fuel tank retaining straps, together with their panel brackets.

18. Fit the two compriband strips around the fuel tank.

19. Bend the retaining straps around the fuel tank, ensuring that they seat onto the compriband strips.

20. Fit a bridge piece to the end of each securing strap. Secure the fuel tank in position by fitting the long bolt, downwards, through the crossmember (if fitted), upper and lower securing strap bridge pieces and straps. Screw a full nut onto the bolt.

21. Repeat Operation 20 to the second set of securing straps.

22. Tighten the full nut of each set of securing straps and lock into position by fitting an additional half-nut to each of the two bolts.

23. Fit the rubber intake pipe to the fuel tank neck and secure the end of the hose with a worm drive clip.

24. Connect the fuel feed hose and return pipe.

Connect the electrical cables to the fuel tank pre-pump.

25. Locate the fuel gauge sender unit electrical loom (see figs. C2-4 and C2-5). There are three cables in the loom and these are coloured black, green/orange, and green/slate.

Tape the cables across the fuel tank until they are adjacent to the fuel sender unit.

26. Connect the cables to the fuel gauge sender unit.

27. Remove the end screw from the battery master switch (if fitted) and remove the knob and special ring nut.

28. Locate the base of the carpet covered panel against the two brackets and clips; on 4 door cars secure with two screws. On 2 door cars connect the luggage compartment lamp and centralized door locking switch electrical cables. Secure the top of the panel with Pozidriv screws, ensuring the panel locates over the battery master switch (if fitted).

29. Fit the battery master switch special ring nut and knob. Secure the knob with the centre screw.

30. Connect the battery.

#### Fuel filler – To remove and fit (4 door cars)

1. Disconnect the battery.

2. Unscrew and remove the Pozidriv screws securing the carpet covered sealing panel at the forward end of the luggage compartment. Remove the centre screw from the battery master switch (if fitted) and remove the knob. Remove the special ring nut.

3. Withdraw the carpet covered sealing panel to reveal the fuel tank assembly.

4. Unscrew and remove the self-tapping screws securing the tools stowage tray. Withdraw the stowage tray.

5. Remove the clips securing the two rubber hoses to the two outer vents on the top of the fuel tank and withdraw the hoses. One hose fits directly on to a vent, while the other fits to a metal pipe which extends across the width of the fuel tank.

6. Unscrew the worm drive clip securing the fuel inlet hose to the fuel tank; detach the hose and blank off the fuel tank inlet.

7. Unscrew and remove the fuel filler cap.

8. Using a screwdriver, unscrew and remove the six screws securing the fuel filler head to the body.

Collect the washers from the retaining screws and

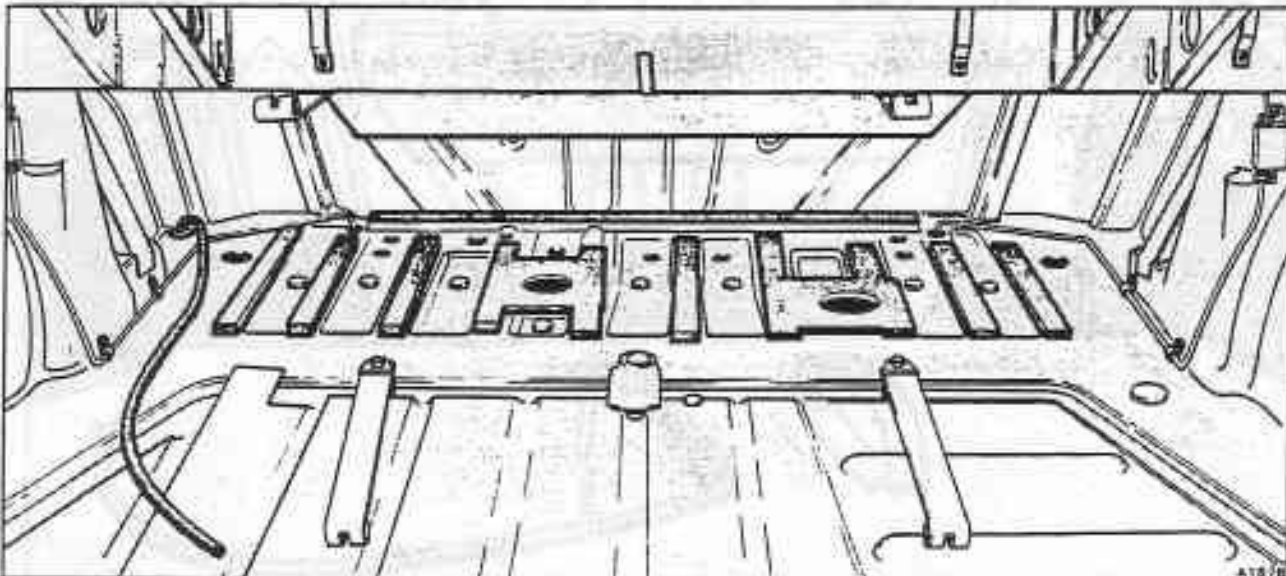

Fig. C2-3 Fuel tank mounting pads and straps (2 door cars)

withdraw the fuel filler head assembly downwards into the luggage compartment.

9. Fit the fuel filler assembly by reversing the procedure given for removal, noting that when fitting the fuel filler head to the body the restrictor should be in its lowest position.

**Fuel filler – To remove and fit (2 door cars)**

1. Remove the carpet covered sealing panel from the forward end of the luggage compartment.
2. Disconnect the two rubber hoses from the outer vents on top of the fuel tank.
3. Unscrew the upper and lower worm drive clips from the fuel filler neck assembly. Withdraw the assembly and blank off the fuel tank.
4. Open the fuel filler flap. Remove the fuel filler cap.
5. Using a screwdriver, unscrew and remove the

screws securing the fuel filler head to the body, collect the washer from beneath the head of each screw. Withdraw the assembly.

6. Fit the fuel filler assembly by reversing the procedure given for removal.

**Fuel pump/fuel accumulator assembly – To remove and fit (see figs. C2-6 and C2-7)**

1. Disconnect the battery.
2. Depressurize the fuel system (refer to page C2-1).
3. Disconnect the electrical cables from the fuel pump, identify each to facilitate assembly.
4. Clamp the flexible fuel hose connecting the fuel tank to the fuel pump.
5. Unscrew the worm drive clip securing the fuel supply hose to the fuel pump inlet connection. Blank off the fuel pump connection.

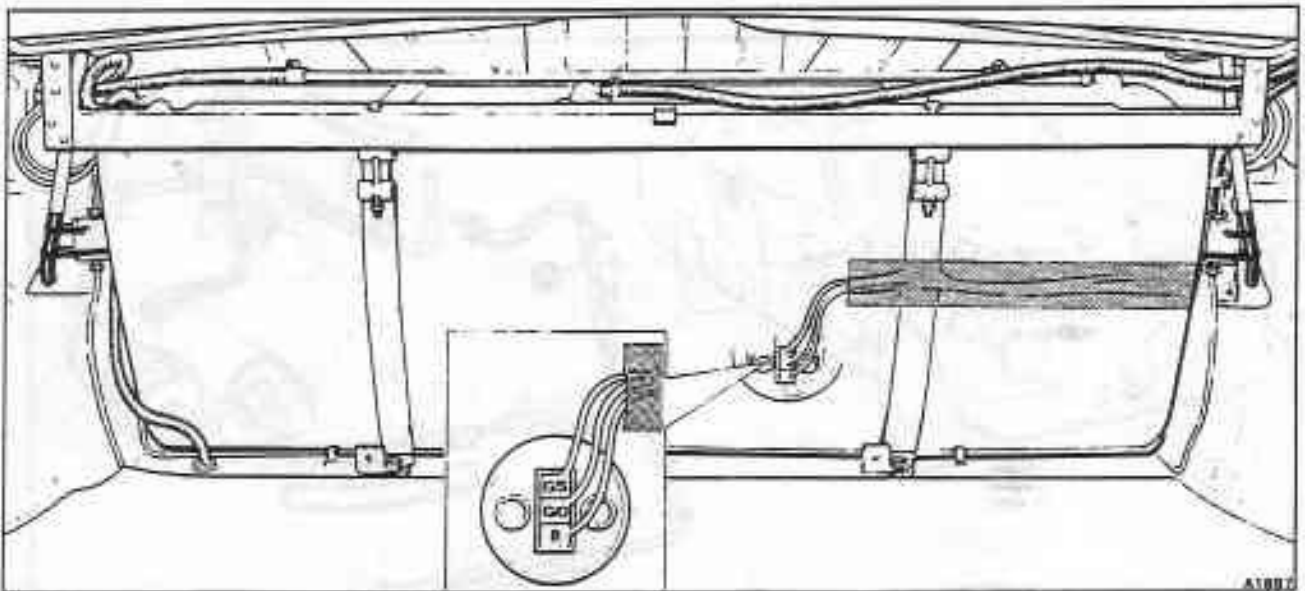

**Fig. C2-4 Fuel tank in position (4 door cars)**

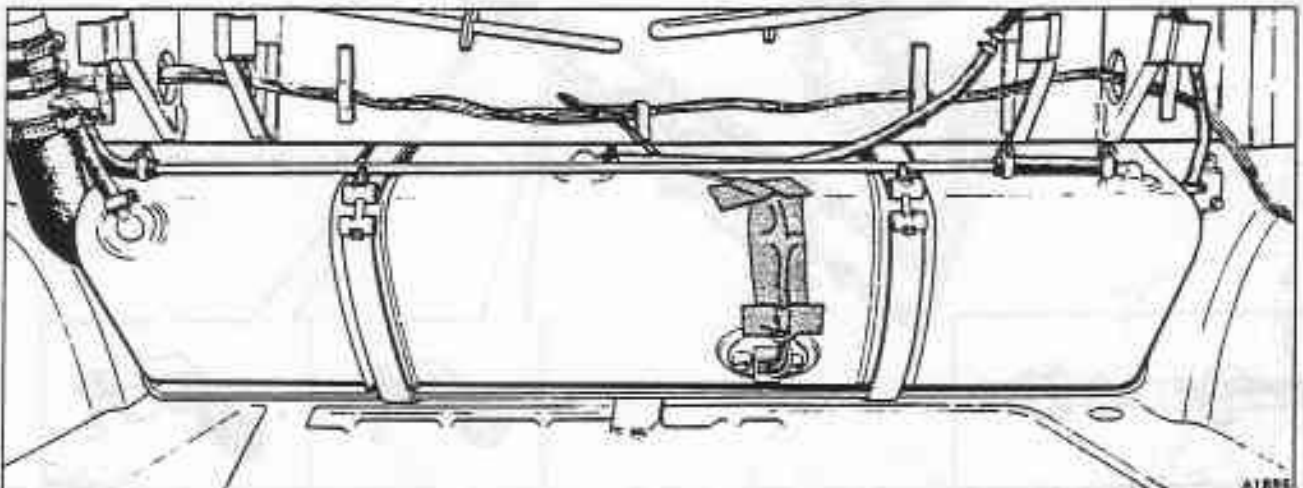

**Fig. C2-5 Fuel tank in position (2 door cars)**



6. Clamp the flexible fuel hose at the rear of the fuel accumulator.
7. Unscrew the worm drive clip securing the hose to the fuel accumulator. Blank off the accumulator connection.
8. Locate the fuel pump/accumulator outlet pipe to flexible feed hose joint. Using a suitable spanner, hold the hexagon of the feed hose. With a second spanner unscrew the pipe nut on the pump outlet.
9. Remove the nuts securing the fuel pump/fuel accumulator assembly to the three metalastik mounts. Support the assembly as the nuts are removed. Lower the assembly from the car.
10. To remove the fuel pump or fuel accumulator from the mounting bracket, remove the fuel pressure damper and metal junction pipe. Release the 'U' bolts or clamp brackets situated around the components. Withdraw the fuel pump and accumulator.
11. Fit the fuel pump/fuel accumulator assembly by

reversing the removal procedure, ensuring that the rubber insulation strips around the pump and accumulator are in good condition.

#### Fuel pressure damper – To remove and fit

1. Disconnect the battery.
2. Depressurize the fuel system (refer to page C2-1).
3. Position a spanner on the hexagon of the fuel pump outlet adapter. Using a second spanner on the hexagon of the damper assembly, unscrew the damper assembly. This will prevent the adapter turning as the damper is unscrewed. Collect the seating washer between the damper and fuel pipe banjo connection.
4. Remove the banjo pipe by unscrewing the pipe connection from the fuel accumulator.
5. Collect the sealing washer from between the banjo pipe and fuel pump adapter.
6. Fit the fuel pump pressure damper by reversing

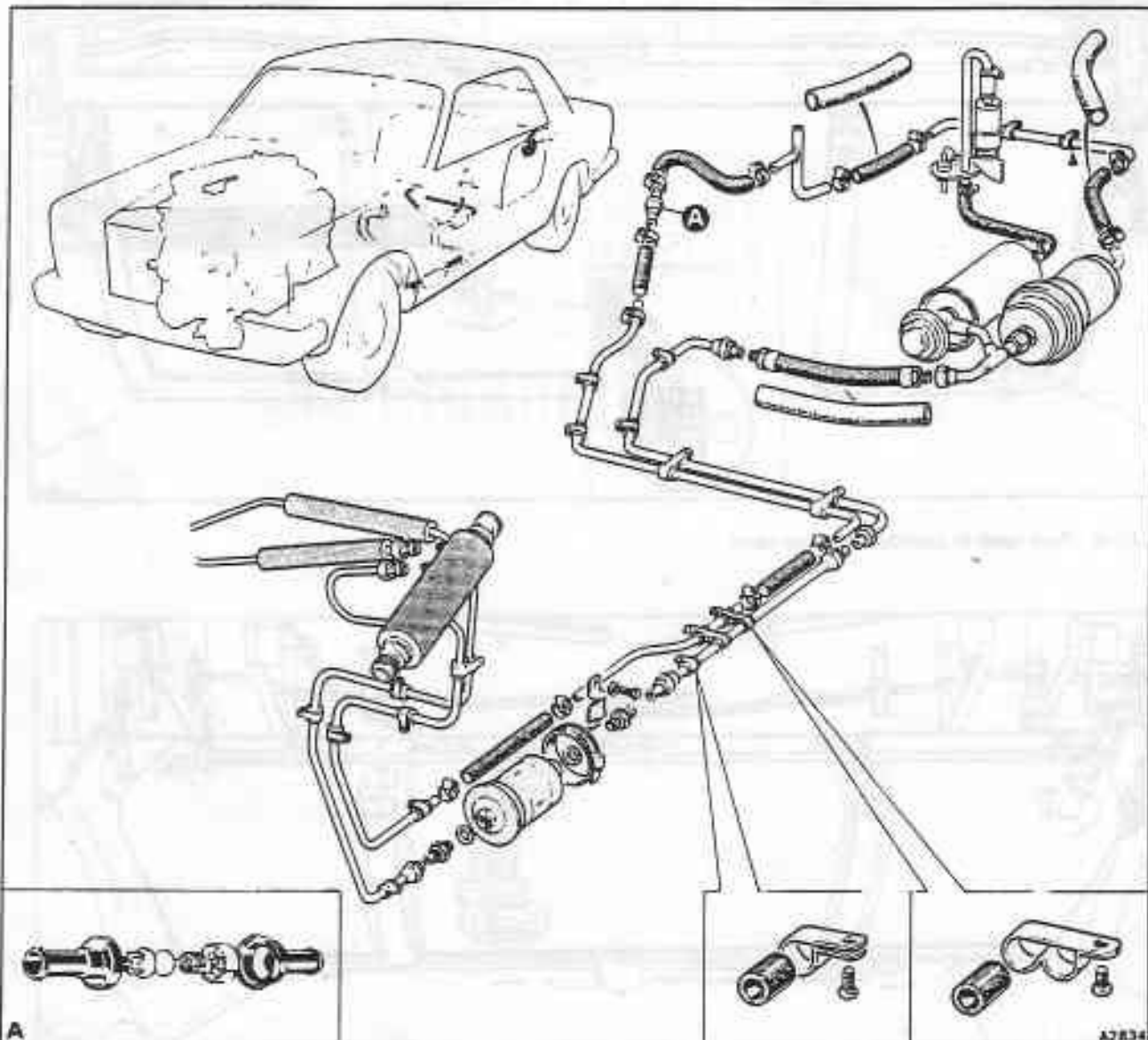

Fig. C2-6 Fuel pipes and fittings

the removal procedure, ensuring that the fuel pump outlet adapter is tight in the fuel pump. Also, ensure that the sealing washers are in good condition and fitted one on each side of the outlet pipe banjo connection.

**Fuel filter – To remove and fit (see fig. C2-6)**

1. Disconnect the battery.
2. Depressurize the fuel system (refer to page C2-1).
3. Unscrew the filter inlet and outlet pipe unions and blank the open connections.
4. Slacken the worm drive clip securing the filter assembly to the mounting bracket; withdraw the filter assembly.
5. If a new filter is to be installed, unscrew the inlet and outlet unions from the ends of the assembly and fit them into the new assembly.

Ensure that the sealing washers are in good condition.

6. Fit the fuel filter by reversing the removal procedure. Note that the rubber insulating strip fitted around the body of the filter is in good condition and the arrows on the side of the filter are pointing in the direction of flow.

**Fuel lines (see fig. C2-6)**

The fuel lines consist of metal bundy tubing and reinforced fuel resistant rubber hoses.

Metal piping is used where possible and is attached to the body and inner longeron by metal clips (with rubber inserts) and self-tapping screws.

Rubber hoses are used where there is a joint or flexibility is required.

Joints in the fuel line on the pressurized (feed) side of the system are usually made by a threaded adapter and union. However, on the unpressurized (return) side of the system a joint is usually effected by a rubber hose and worm drive clip.

**Always depressurize the fuel system before removing any parts connected into the fuel feed line.**

A non-return valve (inset A) is situated in the fuel return line in the vicinity of the final drive unit. This valve is fitted to prevent the back-flow of fuel. The valve is a non-serviceable unit and if its operation is suspect a new assembly should be fitted.

**Fuel return line non-return valve – To remove and fit**

1. Clamp the rubber fuel pipe before and after the valve.

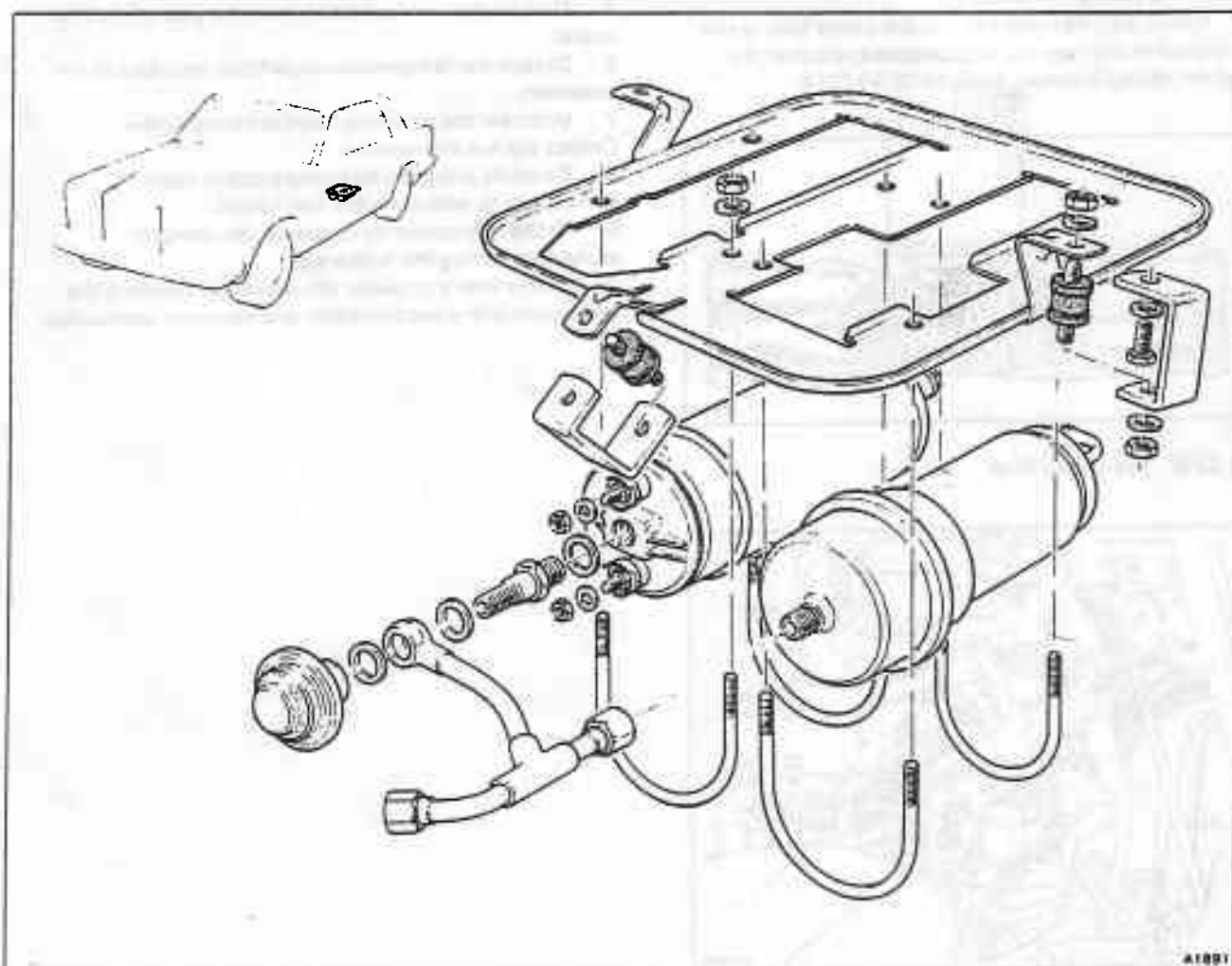

Fig. C2-7 Typical fuel pump/fuel accumulator assembly



2. Slacken the worm drive clips on either side of the valve and withdraw the pipes.
3. Blank off the open pipe connections if the new valve is not fitted immediately.
4. Fit the valve by reversing the removal procedure. Note that flow directional arrows are situated on the valve body.

#### In-tank pre-pump - To remove and fit

1. Carry out the necessary workshop safety precautions (refer to Chapter A).
2. Disconnect and remove the battery.
3. Depressurize the fuel system (refer to page C2-1).
4. Siphon the fuel from the tank.
5. From beneath the car, detach the fuel feed connection at the fuel tank. Blank off the open connections.
6. Disconnect the electrical cables from the in-tank pre-pump. Note the connections to facilitate assembly.
7. Using the special tool RH 9928, turn the locking ring anti-clockwise to remove the pre-pump from the tank.
8. Withdraw the pre-pump and discard the sealing ring.
9. Fit the pre-pump by reversing the removal procedure, noting the following.
  - a. Ensure that the shape of the pre-pump filter is not deformed in any way (i.e. not collapsed and that the support spring is fitted). Refer to figure C2-8.

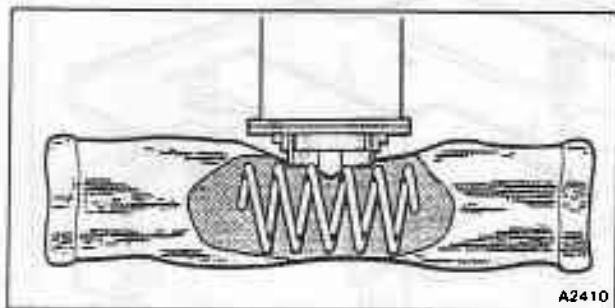

Fig. C2-8 Pre-pump filter

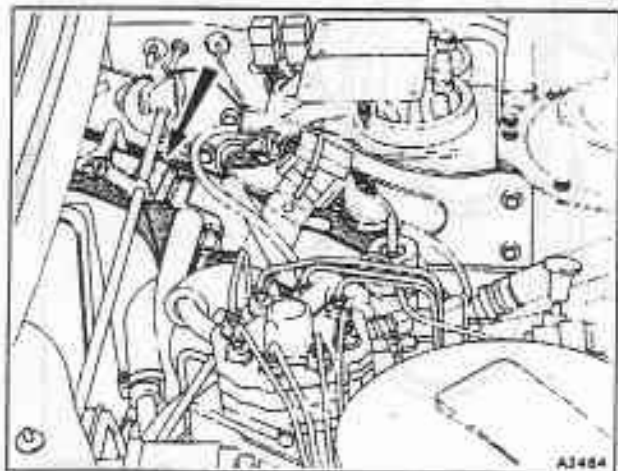

Fig. C2-9 Fuel cooler

- b. Ensure that a new sealing ring is fitted.
- c. Secure the locking ring using the special tool RH 9928.
- d. Ensure that the lug on the locking ring just contacts the stop on the fuel tank outlet. Do not overtighten.

#### Fuel cooler (see fig. C2-9)

A fuel cooler is fitted to all 1989 model year cars. It is located in the rear left-hand corner of the engine compartment.

The fuel cooler is fitted into the fuel return line and utilizes the air conditioning system refrigerant to cool the fuel.

The fuel cooler is therefore, cooling the fuel whenever the air conditioning system compressor is operating.

#### Fuel cooler - To remove and fit

1. Carry out the necessary workshop safety precautions (refer to Chapter A).
2. Disconnect and remove the battery.
3. Discharge the refrigerant (refer to TSD 4700, Chapter C).
4. Depressurize the fuel system (refer to page C2-1).
5. Detach the two fuel pipes from the side of the fuel cooler.
6. Detach the refrigeration pipe from each end of the assembly.
7. Unscrew the retaining bracket clamp screw. Collect the nut and washer.
8. Carefully prise the retaining bracket open sufficiently to withdraw the fuel cooler.
9. Fit the fuel cooler by reversing the removal procedure, noting the following.
10. Ensure that the rubber insulation surrounding the fuel cooler is in good condition and correctly positioned.