

Hydraulic mineral oil reservoirs



WARNING

Use only hydraulic system mineral oil (LHM) to replenish the braking and levelling systems.

Do not use brake fluids (Castrol RR363, Universal, or any other type). The use of any type of brake fluid, even in very small amounts, will cause component failure necessitating extensive rectification to the braking and levelling systems of the car.

Always ensure before fitting any seals, hoses, pipes, etc., that they are suitable for a mineral oil system. For details of correct component identification reference should be made to Section G3 of this Workshop Manual.

Always ensure that two sealed containers of hydraulic system mineral oil (LHM) are fitted in the luggage compartment.

Always ensure that no foreign matter enters the systems when work is being carried out.

Introduction

The two hydraulic mineral oil reservoirs are situated on the left-hand valance of the engine compartment. Mineral oil for System 1 is contained in the inboard (large) reservoir and for System 2 in the outboard (small) reservoir.

To indicate a low mineral oil level, each reservoir contains a float actuated reed switch located inside the float pillar. This switch will cause a facia warning lamp to illuminate should the mineral oil in the reservoir fall below a preset level.

The reservoir filler device contains a spring loaded ball valve. The valve is opened by the filler nozzle situated on the purpose designed containers of hydraulic system mineral oil (LHM).

Two purpose designed containers, each containing 500 ml (17.5 fl oz) of mineral oil, are supplied with each new car. These containers are located within the luggage compartment, behind a trim panel. Before returning the car to a customer always ensure that two unused containers are supplied.

Important Do not refill an empty container.

Providing that the correct precautions are taken against the ingress of dirt into the systems and that perfectly clean hydraulic system mineral oil is always used when topping-up, the reservoirs will only require servicing at the intervals specified in the Service Schedule Manual, TSD 4702.

After any work is carried out on the reservoirs always ensure that the tamperproofing (wire and seal), and warning panel are fitted correctly.

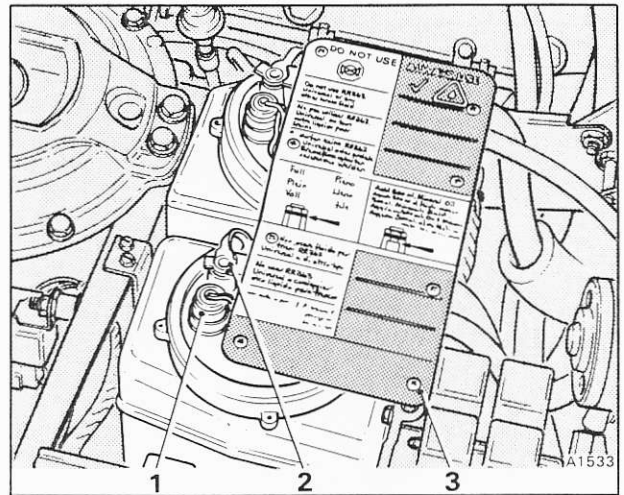

Fig. G7-1 Hydraulic system mineral oil reservoirs

- 1 Level indicator sight glass
- 2 Filler connection
- 3 Multi-lingual warning panel

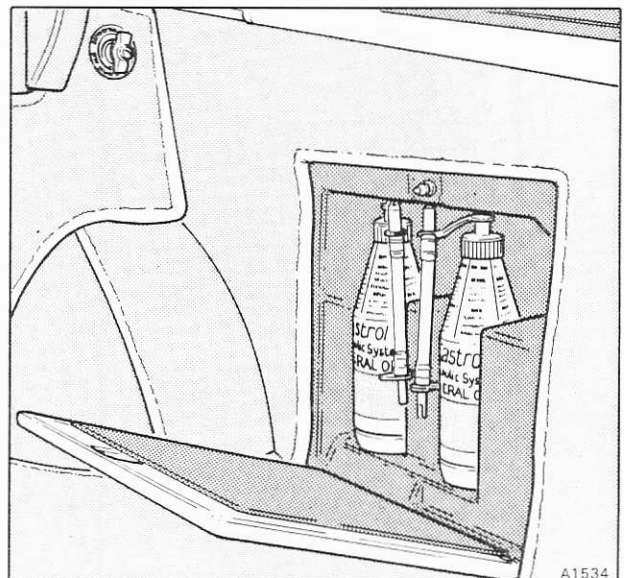

Fig. G7-2 Hydraulic system mineral oil bottle stowage (Four door cars)

Hydraulic mineral oil reservoirs – To remove (see figs. G7-1 and G7-5)

The reservoirs must be removed from their support brackets together.

1. Depressurize the hydraulic systems as described in Section G3.
2. Disconnect the battery.



3. Remove the multi-lingual warning panel assembly from the top of the reservoirs. Ensure that the tops of the reservoirs are wiped clean.
4. Disconnect the electrical leads from the top of each reservoir.

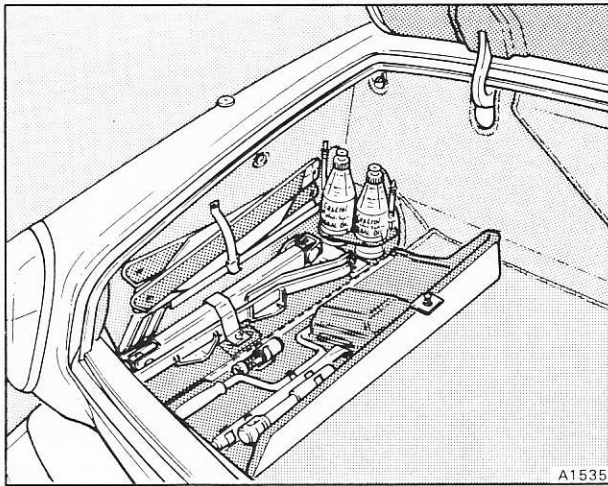

Fig. G7-3 Hydraulic system mineral oil bottle stowage (Corniche/Continental)

5. Remove the clips securing the pipes to the inner longeron and then disconnect the pipes from the tops of the reservoirs. Four of the pipes have flexible rubber hose connections, the others lift directly from the reservoir manifold.

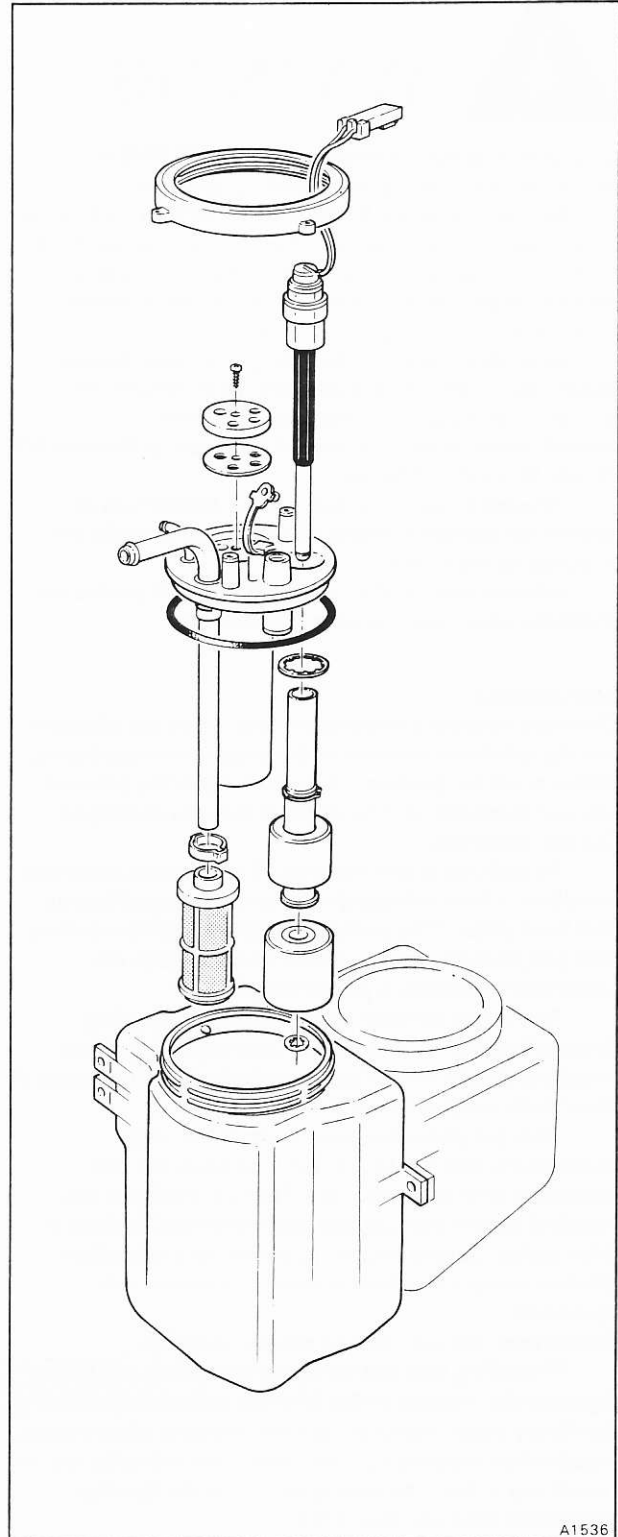

Fig. G7-5 Hydraulic system mineral oil reservoir

DO NOT USE	ALWAYS USE
<p>Do not use RR363, Universal, or any other brake fluid.</p>	<p>Use only Hydraulic System Mineral Oil (LHM) from special container. Spare container in luggage compartment</p>
<p>Ne pas utiliser RR363, Universal, ou tout autre liquide pour freins.</p>	<p>Utiliser seulement de l'huile minérale pour système hydraulique (LHM) provenant d'un conteneur spéciale. Conteneur de réserve dans le coffre à bagages</p>
<p>Es dürfen keine RR363, Universal oder andere Bremsflüssigkeiten verwendet werden.</p>	<p>Nur Mineralöl (LHM) für Hydrauliksystem aus dem Spezialbehälter verwenden. Ersatzbehälter im Gepäckraum.</p>
<p>Full Pieno Plein Llano Voll مملوء</p>	<p>Add 500 ml. Mineral Oil Ajouter 500 ml. d'huile minérale 500 ml. Mineralöl einfüllen Aggiungere 500 ml di Olio Minerale Agregar 500 ml de aceite mineral</p>
<p>Non usare fluido per freni RR363, Universal o di altro tipo.</p>	<p>Usare solo olio minerale per impianti idraulici (LHM) dal contenitore speciale. Contenitore di scorta nella bauletta.</p>
<p>No usar RR363, Universal o cualquier otro líquido para frenos</p>	<p>Usar solamente aceite mineral para sistema hidráulico (LHM) del recipiente especial. Se incluye recipiente de reserva en el maletero.</p>
<p>لا تستخدم آر آر ٣٦٣ أو يونيفرسال أو أي سائل آخر للفرامل</p>	<p>استعمل زيت نظام الهيدروليك المعدس (LHM) فقط والموحود في الحاوية الخاصة. هذا لك حصة احتياطية في صندوق الامتعة</p>
<p>WARNING. CLEAN FILLER PLUG BEFORE REMOVING. USE ONLY HYDRAULIC SYSTEM MINERAL OIL FROM SEALED CONTAINER.</p>	

Fig. G7-4 Hydraulic system mineral oil multi-lingual warning panel

6. Blank off the pipe ends and the circular manifold covers in the reservoir lids.
7. Remove the two drill screws securing the reservoir bracket to the spring cover support bracket.
8. Remove the three setscrews securing the reservoirs to the side support brackets. Two setscrews secure the reservoirs to the bracket between the spring cover and the bulkhead, and one setscrew secures the small reservoir to the support bracket below the electrical relays.
9. Lift the reservoir assembly clear of the brackets, taking care not to damage any pipes.

Reservoirs – To dismantle, clean, and assemble (see fig. G7-5)

1. Remove the reservoirs as described under Hydraulic mineral oil reservoirs – To remove.
2. Remove the tamperproofing wire and seal between the two reservoirs.
3. Remove the setscrew securing the two reservoirs together.
4. Turn each reservoir over and drain the mineral oil into a container.
5. Using tool RH 9885 remove the locking ring securing the reservoir lid.
6. Lift the lid from the reservoir, noting that it will only fit one way into the reservoir. Discard the sealing ring.
7. Remove the star washer from the base of the float assembly shaft. Withdraw the floats and green indicator stem.

Note The bottom float has a magnet in the **top** face. Ensure it is fitted correctly when assembling.

8. The sight glass/float pillar assembly is a serviceable item. The float pillar is bonded to the sight glass, which is an interference fit in the reservoir lid. Therefore, the float pillar assembly should only be removed from the reservoir lid in the event of the reed switch being inoperative.

To remove the float pillar, remove the star washer from the base of the sight glass on the underside of the reservoir lid. Push the sight glass/float pillar assembly out of the reservoir lid. Discard the sight glass/float pillar.

9. Remove the reservoir filter from the outlet pipe by removing the crimped securing clip.

Note When removing the outlet filter, care must be taken to ensure that the fine mesh of the filter is not torn or damaged.

Care must also be taken during dismantling and cleaning to ensure that the reed switch stem is not bent or damaged, as this will cause the switch to be inoperative.

10. Remove the screw securing the manifold in each reservoir lid. Pull out the manifold and rubber seal. Ensure the manifold and seal are kept with their respective reservoir.

Note The seals are not interchangeable between large and small reservoirs.

11. Thoroughly clean all parts with petroleum ether (120/160°C), drying them with dry compressed air.

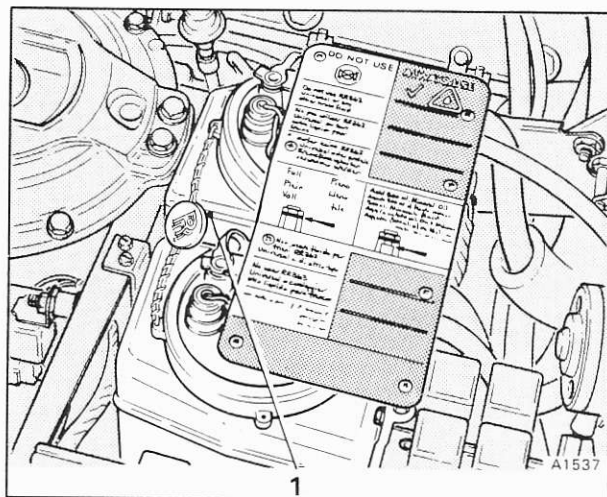

Fig. G7-6 Hydraulic reservoirs tamperproofing
1 Wire and seal

Ensure that all holes and pipe outlets are carefully cleaned and have blanks fitted.

12. Assemble the reservoirs by reversing the dismantling procedure noting the following.
13. Always use a new sealing ring on the reservoir lid, and new star washers.
14. Ensure the slot in the reservoir lid engages the locating spigot on the inside of the reservoir neck.
15. The reservoir lid requires **one full turn** of thread engagement. Ensure the ears on the lid of the small reservoir will not foul on the large reservoir when they are secured together.
16. Fit a new tamperproofing wire and seal between the reservoirs (see fig. G7-6).

Reservoirs – To fit and top-up

Fit the reservoirs by reversing the procedure given for removal noting the following.

1. When the reservoirs have been fitted, ensure that the bundy pipes are pushed fully into the reservoir manifold (e.g. the swaged part of the pipe engages with the rubber seal).
2. Ensure the multi-lingual warning panel is fitted.
3. Fill the reservoirs with clean hydraulic system mineral oil (see Chapter D), until the top of the green indicator tube is approximately 3 mm (0.125 in) below the bottom edge of the black ring on the indicator sight glass.
4. Run the engine for approximately four minutes with the car unladen, then top-up the reservoirs until the top of the green indicator tube is just **above** the top of the black ring on the indicator sight glass, [approximately 1 to 2 mm (0.040 to 0.080 in)]. Never allow the mineral oil level to fall below the minimum level (e.g. top of the green indicator tube **below** the bottom of the indicator sight glass).
5. Check for leaks, especially around all pipes, connections, etc., which have been disturbed.
6. The hydraulic systems must then be bled completely as described in Section G5.

Hydraulic pumps

Introduction

The mineral oil hydraulic pumps can be distinguished from those using conventional brake fluid, in that each pump has a green disc fitted beneath the top adapter (see figs. G8-1 and G8-2).

Internally the mineral oil pump has a larger diameter plunger than the pumps using RR 363 brake fluid. Also, the seals are made of material that meets mineral oil requirements.

The brake pump push rod has a collapsible section of increased diameter. The top edge of the push rod is chamfered for identification purposes (see fig. G8-1).

Never fit a brake pump push rod from a conventional (RR 363) brake fluid system as a replacement.

When overhauling a mineral oil brake pump always ensure that sealing rings bearing mineral oil identification marks are fitted (see Section G3).

Hydraulic pump housing sealing rings – To renew (see fig. G8-2)

If hydraulic system mineral oil leakage occurs from a brake pump housing, it is possible to renew the two sealing rings with the pump in position.

1. Depressurize the hydraulic systems as described in Section G3.
2. Ensure that the pump and surrounding area is thoroughly cleaned.
3. Compress the rubber hose section of the hydraulic pump low pressure inlet pipe to prevent mineral oil flow. Remove the hose from the pump inlet pipe and blank the end of the hose.
4. Disconnect the high pressure outlet and low pressure inlet pipes from the hydraulic pump.
5. Remove the circlip from the top of the pump. Withdraw the outer housing upwards and off the pump.
6. Discard the two sealing rings. Fit new sealing rings after lubricating with clean hydraulic system mineral oil of the approved type.
7. Fit the pump outer housing with care, aligning the port with the inlet pipe. Press the housing firmly into position, then fit the circlip (see fig. G8-2).
8. Prime the pump with an approved hydraulic system mineral oil. Connect the low pressure feed and high pressure outlet pipe to the pump.
9. Top-up the reservoir(s) with an approved hydraulic system mineral oil (see Chapter D). Bleed the hydraulic systems as described in Section G5.

Hydraulic pump – To remove

1. Carry out Operations 1 to 5 inclusive of, Hydraulic pump housing sealing rings – To renew.
2. Using the special box spanner RH 8428, unscrew and remove the pump from its pedestal on the tappet

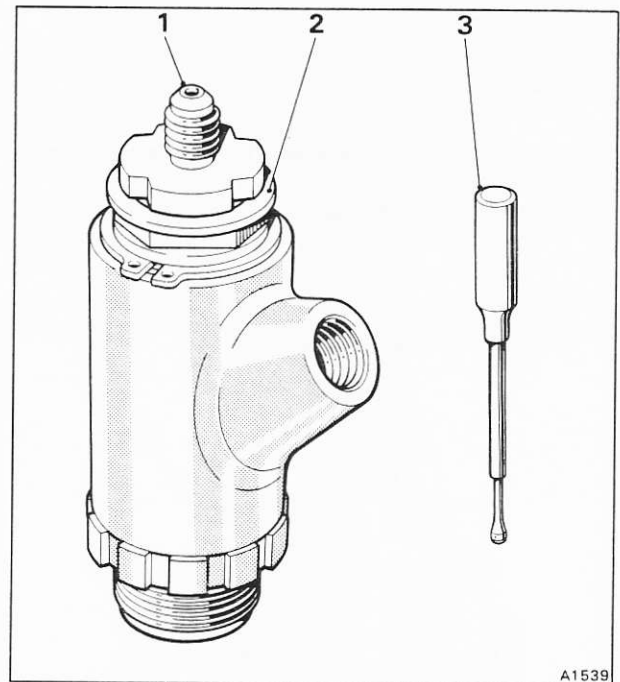

Fig. G8-1 Mineral oil hydraulic pump identification features

- 1 Smaller pipe connection
- 2 Green disc
- 3 Chamfered end face – Push rod

chest cover. Blank off the pedestal against the ingress of dirt.

Note The pump must not be removed by using the top adapter as a spanning point.

Hydraulic pump – To dismantle (see fig. G8-2)

When two pumps are being dismantled the components from each pump must not be interchanged.

1. Release the lock-nut situated at the top of the brake pump.
2. Remove the adapter from the top of the pump and withdraw the non-return valve assembly from the bore.

Note Special tools RH 9814 and RH 9844 will be required.

Gentle use of a small screwdriver may be necessary to assist removal of the chamfered washer. The washer should be discarded and a new one fitted on assembly.

3. Remove the inlet valve ring, spacer ring, and conical valve spring.
4. From the lower end of the pump, remove the circlip. Withdraw the plunger and spring.

5. Carefully withdraw the plunger barrel from the pump body.
- Note** The barrel and plunger are matched ground components and are **not** interchangeable.
6. Remove and discard the three 'O' rings from the pump body.
 7. To dismantle the non-return valve assembly, remove the circlip, push out the valve from the outer body and collect the spring, end stop, and valve.

Hydraulic pump components – To clean and inspect

Ensure that all tapped holes are free from foreign matter and slivers of thread which might break off

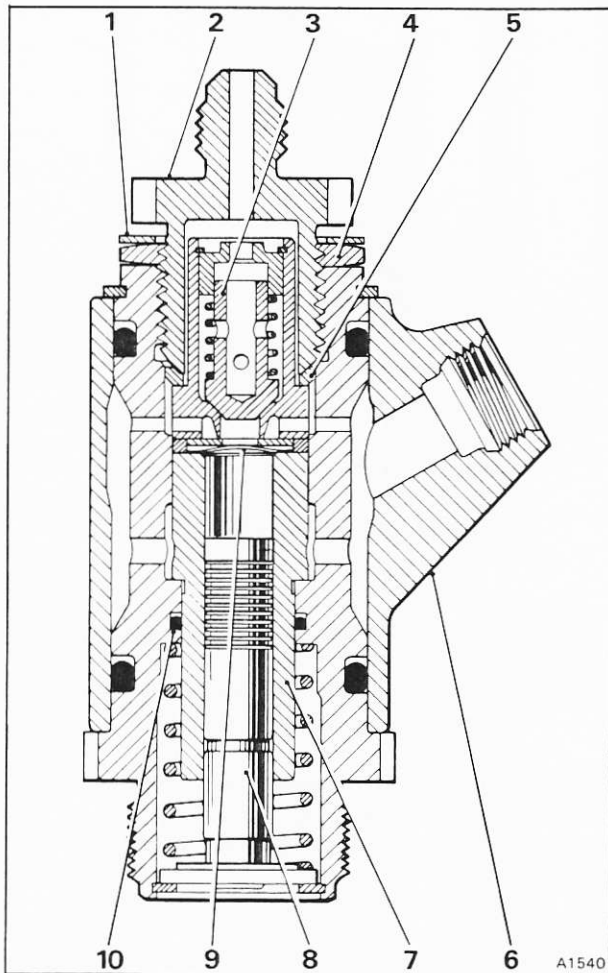

Fig. G8-2 Hydraulic pump

- 1 Identification disc
- 2 Adapter – high pressure outlet
- 3 Non-return valve
- 4 Lock-nut
- 5 Chamfered ring
- 6 Outer housing (reversed for front pump)
- 7 Pump barrel
- 8 Plunger
- 9 Inlet valve spring
- 10 Sealing ring

during assembly and become entrapped in the hydraulic system. One method of achieving this is to screw slave adapters or pipe nuts down the threads before thoroughly cleaning the components in petroleum ether (120/160°C), and drying with dry compressed air, not with any type of cloth.

It is important that the seating of the valves is correct and that the finely machined barrel and plunger are not scored or damaged.

Under normal circumstances after a thorough cleaning and the introduction of a new set of sealing rings, the only parts that might need renewal are the small coil springs.

Hydraulic pump – To assemble (see fig. G8-2)

Ensure that all sealing rings used, are for use with hydraulic system mineral oil.

1. Lubricate all parts including the sealing rings with an approved hydraulic system mineral oil (see Chapter D), prior to fitting in their respective positions.
 2. Fit the small 'O' ring into position in the centre bore of the pump body.
 3. Insert the plunger barrel into the pump body, pressing it through the sealing ring until it abuts the shoulder.
 4. Insert and locate the spacer ring; fit the valve spring (crowned face towards the inlet valve), and the inlet valve into position adjacent to the barrel head. Ensure that the seating face of the valve is free from damage marks, otherwise the efficiency of the pump will be reduced.
 5. Assemble the non-return valve, by reversing the procedure given for dismantling. Ensure that the valve is fully seated and the circlip is correctly located in its groove. The end stop should be drawn upwards to abut the circlip.
 6. Fit the non-return valve assembly, larger diameter leading, into the pump body adjacent to the spacer ring.
 7. Fit a new chamfered sealing ring, small bore diameter leading, into the pump body bore so that it abuts the shoulder of the non-return valve assembly.
 8. Fit the adapter, identification disc, and lock-nut to the top of the pump body. Torque tighten the adapter to the figures quoted in Section G22. Special tools RH 9814 and RH 9844 will be required. Blank off the adapter.
 9. Fit the coil spring into the lower end of the pump body.
 10. Fit the spring to the barrel plunger and carefully insert the plunger into the bore of the barrel.
 11. Depress the plunger against spring pressure sufficiently to enable the circlip to be fitted into its location.
 12. Fit the two 'O' rings to the outside of the pump body, after lubricating with suitable mineral oil (see Chapter D).
 13. Fit the pump outer housing with care. Press the housing firmly into position, then fit the circlip.
- Note** The front pump outer housing inlet port faces downwards, the rear pump inlet port faces upwards.



Hydraulic pump – To fit

To fit the pumps to the tappet cover, reverse the procedure given for removal noting the following.

1. Using the special box spanner RH 8428, torque tighten the pumps to the figures given in Section G22.

Note The top adapter must not be used as a spannering point.

2. Bleed the hydraulic systems as described in Section G5. Check all disturbed pipe connections for leaks.

Hydraulic pumps – To test (on the car)

1. Depressurize the system as described in Section G3.
2. Disconnect the accumulator to reservoir return pipe from the appropriate reservoir. Attach a tube onto the end of the pipe and secure the other end of the tube in a clean measuring vessel.
3. Open the bleed screw on the accumulator.
4. Ensure that the appropriate reservoir is full and then start the engine.
5. Hydraulic system mineral oil should flow from the tube in a series of spurts, coinciding with each revolution of the camshaft. The rate of flow should be approximately 300 ml per minute, at an engine speed of 1000 rev/min.
6. If hydraulic system mineral oil does not flow, or the pumped quantity is below requirements, the pump should be removed and overhauled.