



Relays

Contents	Specific application	Pages							
		Rolls-Royce Silver Spirit	Silver Spur	Corniche / Corniche II	Bentley Eight	Mulsanne	Mulsanne S	Turbo R	Continental
Introduction, general information, and operation		4-2	4-2	4-2	4-2	4-2	4-2	4-2	4-2
Relays – location	1987 model year right-hand drive cars	4-3	4-3	4-7	4-3	4-3	—	4-3	4-7
	1987 model year left-hand drive cars	4-4	4-4	4-8	4-4	4-4	—	4-4	4-8
	1988 model year right-hand drive cars	4-5	4-5	4-9	4-5	—	4-5	4-5	4-9
	1988 model year left-hand drive cars	4-6	4-6	4-10	4-6	—	4-6	4-6	4-10

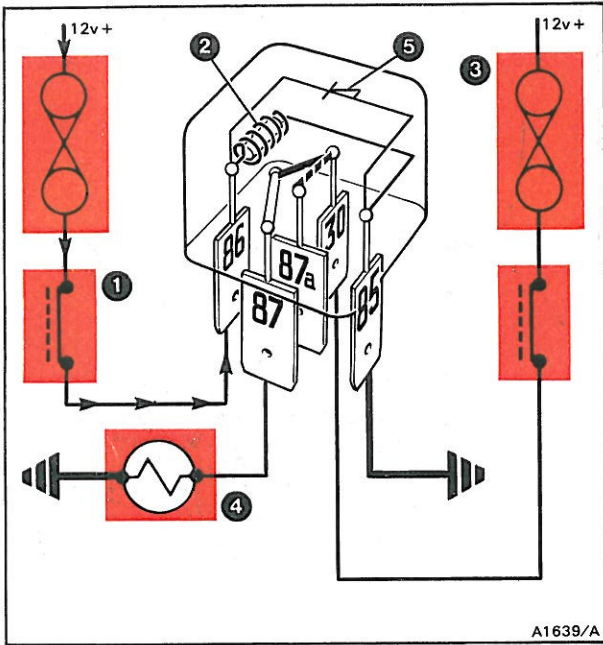

Fig. 4-1 Switching relay – energized

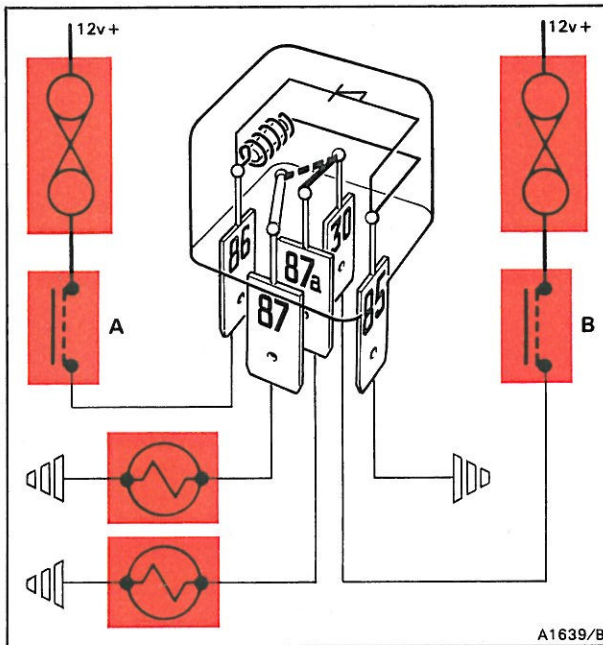

Fig. 4-2 Change-over relay – isolated

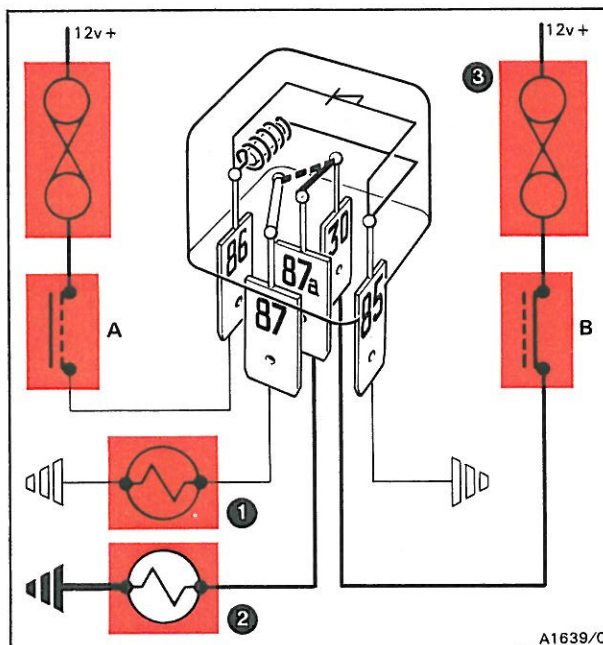

Fig. 4-3 Change-over relay – unenergized

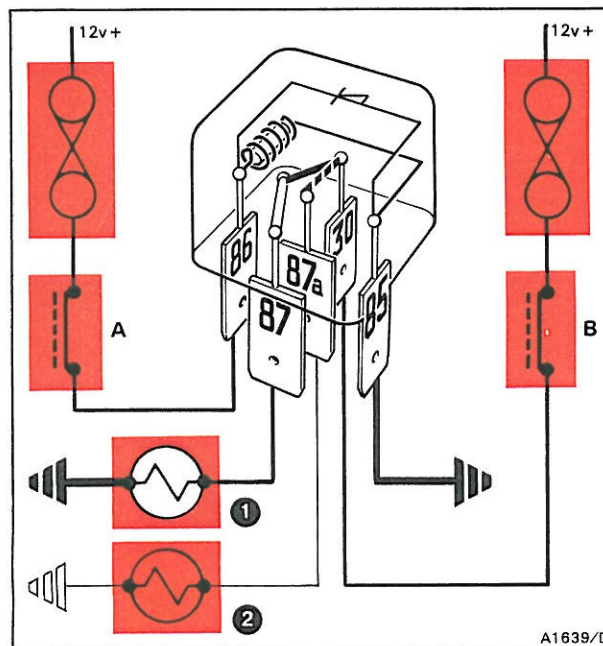

Fig. 4-4 Change-over relay – energized

Introduction

The fitting of certain relays is dependent upon individual car specifications. For example on cars conforming to a Japanese or North American specification which prohibits the fitting of rear fog lamps, the rear fog lamps relay is omitted. Reference should be made to the keys for the illustrations to determine whether a relay is fitted to a particular car.

The majority of relays fitted on the car are interchangeable, however, there are a number of exceptions as follows.

Relays that are not interchangeable – stop lamp failure, headlamps sequencing, headlamps relay 2 – dim/dip facility, headlamps power wash timer, and the anti-lock braking system modulator relay.

Relays that are only interchangeable with one another – the fuel injection system control relay (Turbocharged cars) and the anti-lock braking system relay.

Location

The relays are mainly positioned in groups which are readily accessible. The exceptions being as follows.

The group of relays on the driver's side of the car which necessitates the removal of the knee roll trim panel.

The relays in the luggage compartment which require the removal of the luggage compartment side trim panels.

On Corniche, Corniche II, Continental cars, and cars other than those fitted with seat memory facility, relays are mounted on the front seat mechanisms, access to which is gained by removing the seat cushions.

Certain Corniche, Corniche II, and Continental cars also have relays fitted into the centre console, access to the relays requires the removal of the centre console.

Operation

A relay is an electrically operated control that is activated from a separate component, for example a switch. Fitting a relay into a circuit eliminates the need for fitment of a heavy duty type switch.

Most relays have a diode incorporated (see fig. 4-1, item 5) its function being to reduce interference.

An example of how a circuit containing a relay operates is shown in figure 4-1. When the contacts of the switch (item 1) are closed the control circuit of the relay (indicated by the arrowed lines) provides a 12 volt positive feed to the relay coil (item 2) thus energizing the coil. Energizing the coil causes the normally open contacts marked 30 and 87 to close. This allows a 12 volt positive feed from the supply circuit fuse (item 3) to be fed through the contacts to supply the component (item 4).

Relays are also used to provide change-over functions i.e. to change from one circuit to another. An example of how the change-over function is accomplished is shown in figures 4-2, 4-3, and 4-4. With both switches (A and B) in the open position (see fig. 4-2) lamps 1 and 2 are extinguished. By closing the contacts of switch B (see fig. 4-3) a 12 volt positive feed from the supply fuse (item 3) passes through the normally closed relay contacts 30 and 87a to illuminate lamp 2.

Operation of switch A (see fig. 4-4) energizes the relay coil. This transfers the feed from relay contacts 30 and 87a to contacts 30 and 87, causing lamp 2 to extinguish and lamp 1 to illuminate.

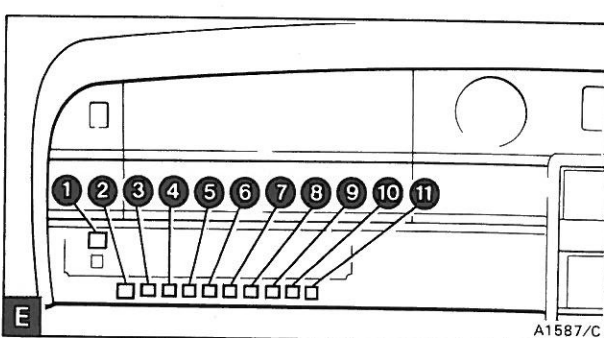
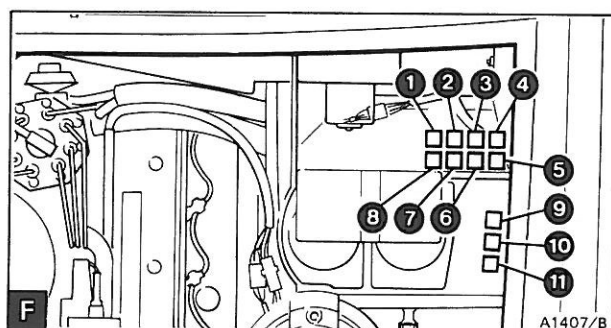
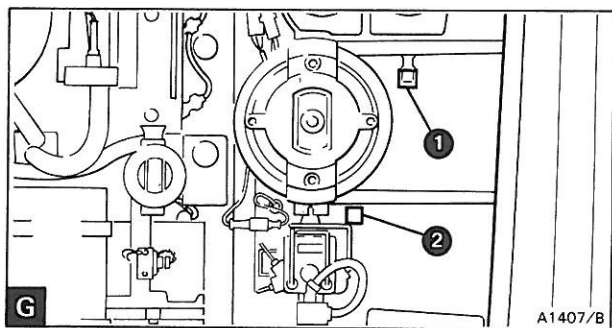
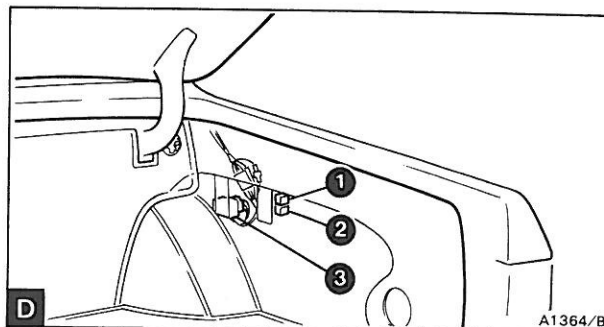
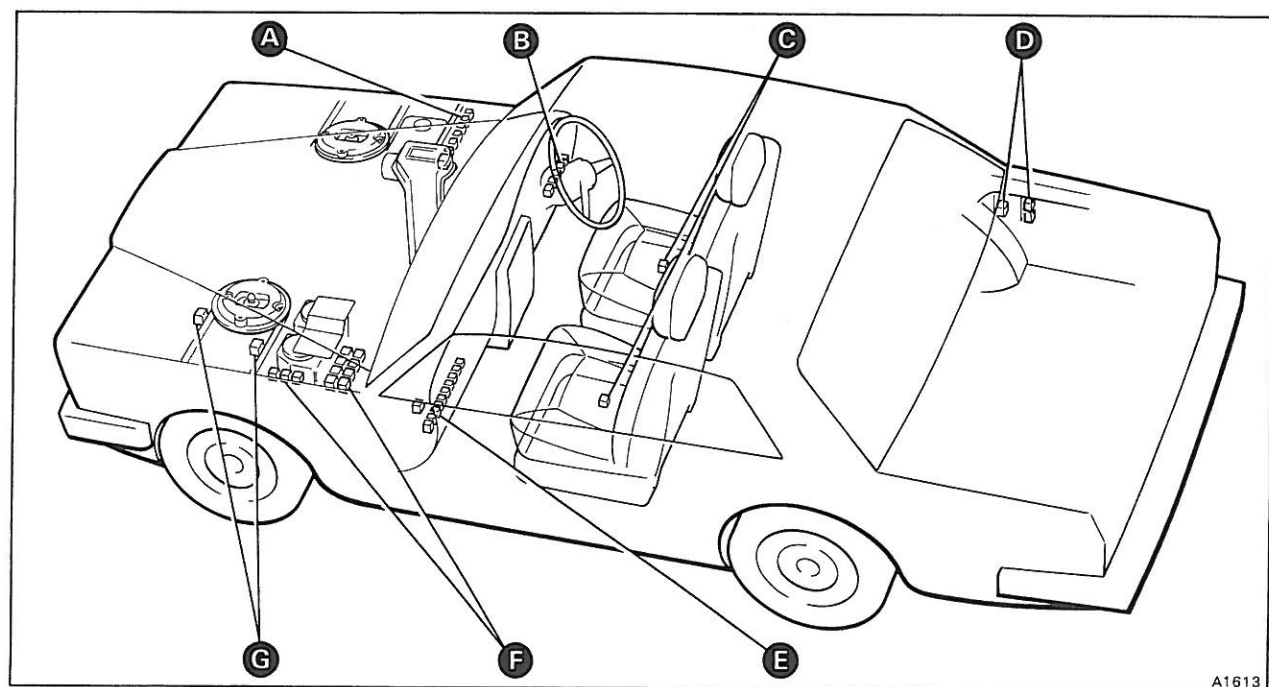
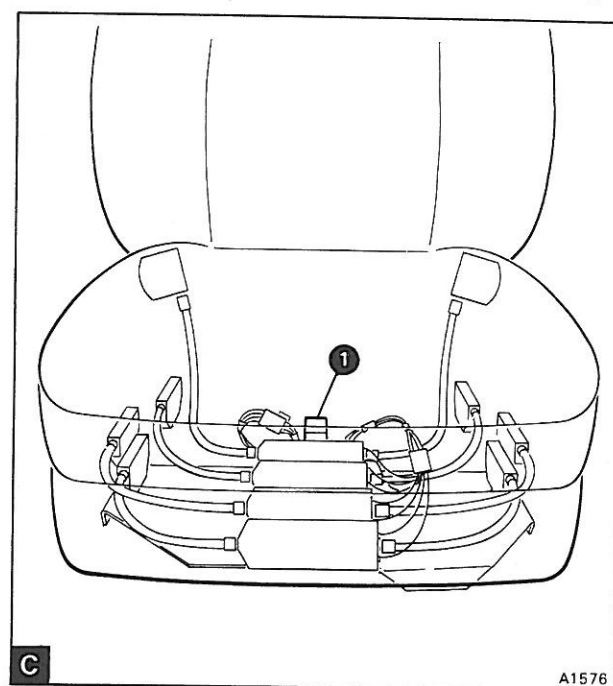
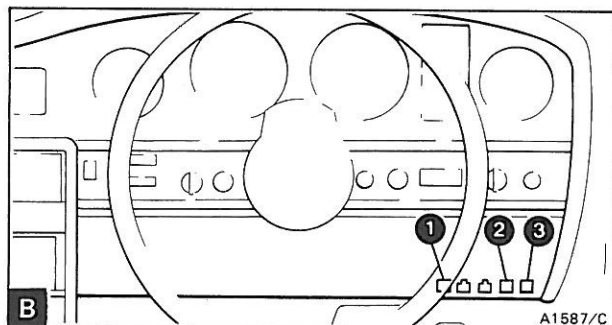
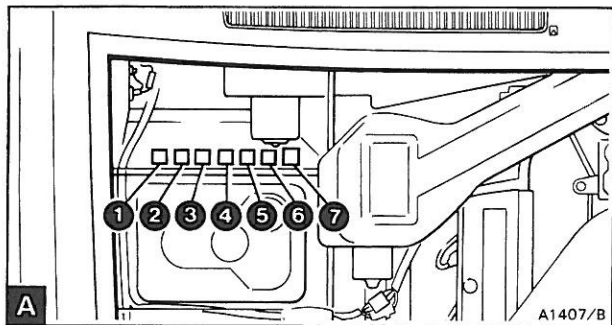

Key to 4-3

- A**
- 1 Windscreen wipers 1
 - 2 Windscreen wipers 2
 - 3 Windscreen wipers 3
 - 4 Starter
 - 5 Starter inhibit
 - 6 Kick-down (Turbocharged cars and those conforming to an Australian or Japanese specification)
 - 7 Fuel injection control (Turbocharged cars only)

- B**
- 1 Rear fog lamps (if fitted)
 - 2 Window lifts (Cars conforming to an Australian specification)
- Note** On cars conforming to a Japanese or United Kingdom specification, the relay is not fitted and the black and black/slate cables are interlinked at the relay base
- 3 Warm-up regulator inhibit

- C**
- 1 Front seats (Cars other than those fitted with seat memory facility)

- D**
- 1 Auxiliary start
 - 2 Rear window demister
 - 3 Stop lamp failure

- E**
- 1 Anti-lock braking system (Cars other than those conforming to an Australian or Japanese specification)
 - 2 Headlamps power wash timer
 - 3 Cranking interlock
 - 4 Radio
 - 5 Fuel filler door
 - 6 Warning lamps dimming
 - 7 Warning lamps test
 - 8 Centralized door locking unlock
 - 9 Centralized door locking lock
 - 10 Headlamps relay 1
 - 11 Headlamps relay 2 – dim/dip facility
- Note** On right-hand drive cars other than those fitted with headlamps dim/dip facility, the relay is not fitted and terminals 2 and 8 are interlinked at the relay base

- F**
- 1 Fan speed 1
 - 2 Fan speed 2
 - 3 Fan speed 3
 - 4 Fan speed 4
 - 5 Water tap
 - 6 Compressor clutch
 - 7 Headlamps flash
 - 8 Fans control
 - 9 Air horns (if fitted)
 - 10 Windtone horns
 - 11 Engine cooling fans

- G**
- 1 Headlamps sequencing
 - 2 Anti-lock braking system modulator (Cars other than those conforming to an Australian or Japanese specification)

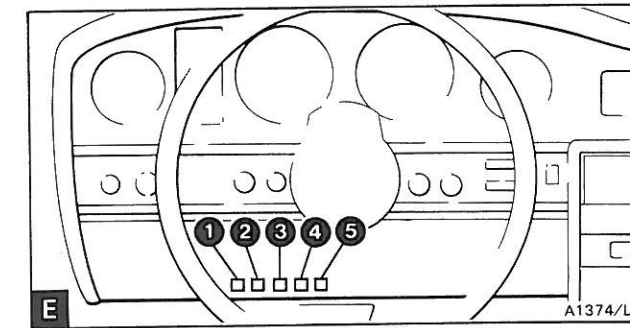
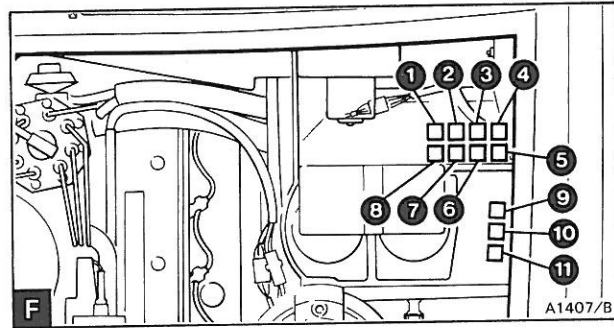
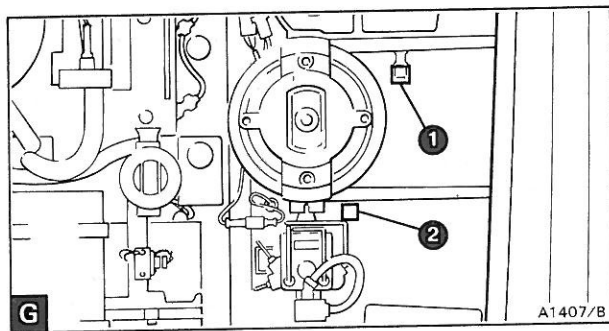
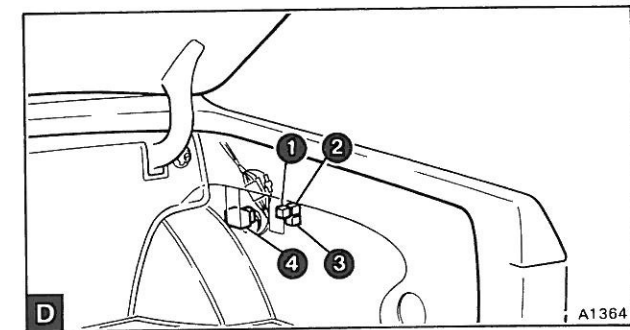
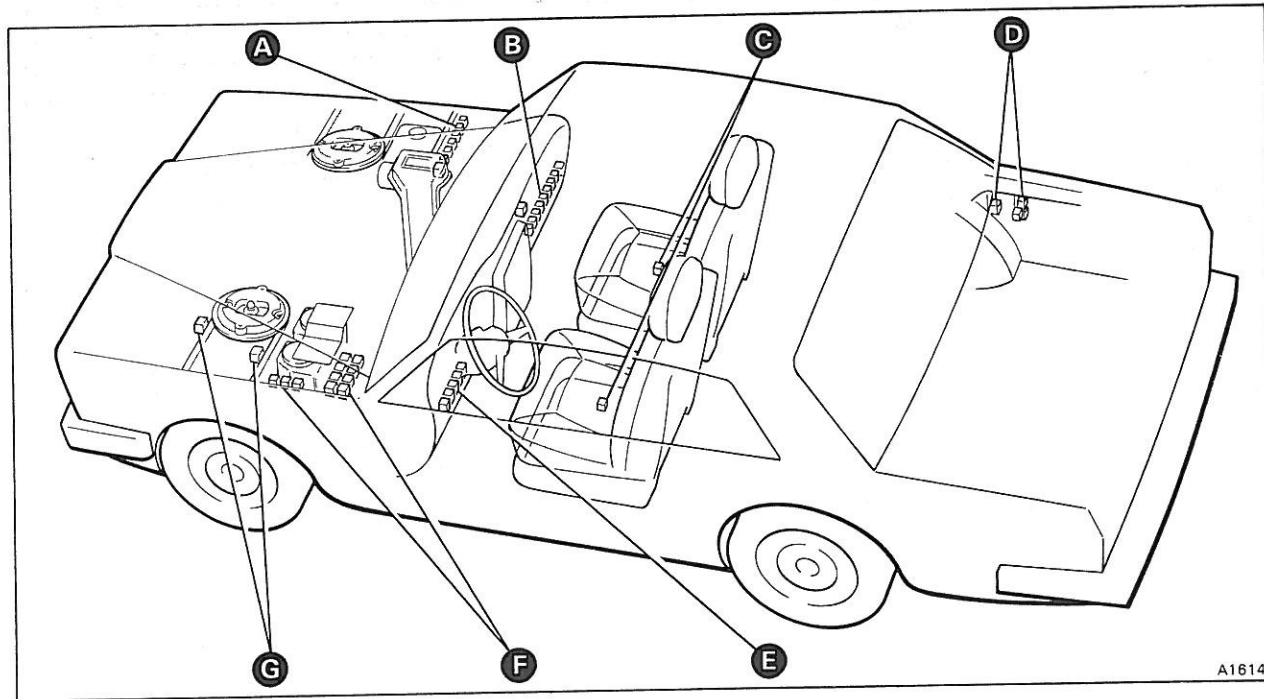
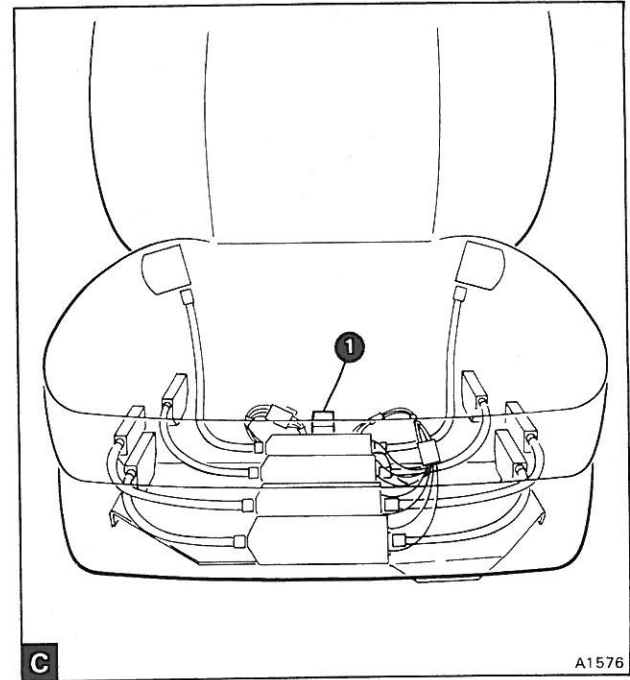
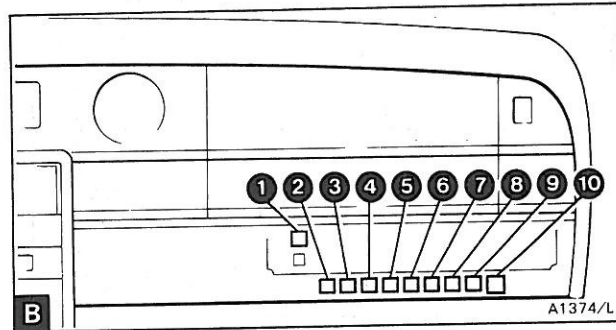
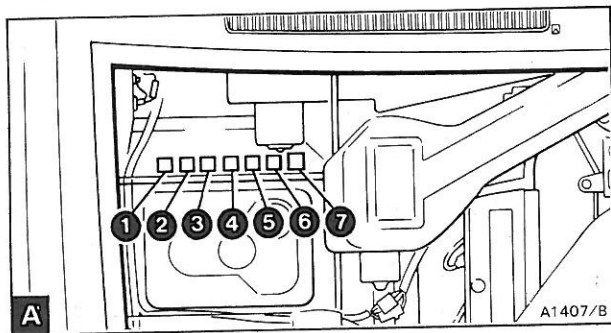

Key to 4-4

- A**
- 1 Windscreen wipers 1
 - 2 Windscreen wipers 2
 - 3 Windscreen wipers 3
 - 4 Starter
 - 5 Starter inhibit
 - 6 Kick-down (Turbocharged cars and those conforming to a Japanese or North American specification)
 - 7 Fuel injection control (Turbocharged cars only)
- B**
- 1 Anti-lock braking system (Cars other than those conforming to a Japanese or North American specification)
 - 2 Headlamps relay 1
 - 3 Centralized door locking lock
 - 4 Centralized door locking unlock
 - 5 Warning lamps test
 - 6 Warning lamps dimming
 - 7 Fuel filler door
 - 8 Radio
 - 9 Cranking interlock
 - 10 Headlamps power wash timer
- C**
- 1 Front seats (Cars other than those fitted with seat memory facility)
- D**
- 1 High mounted stop lamp (Cars conforming to a North American specification)
 - 2 Auxiliary start
 - 3 Rear window demister
 - 4 Stop lamp failure

- E**
- 1 Warm-up regulator
 - 2 Window lifts (Cars conforming to a European or North American specification)
Note On cars conforming to a Japanese specification, the relay is not fitted and the black and black/slate cables are interlinked at the relay base
 - 3 Window lifts latch (Cars conforming to a North American specification)
 - 4 Driver's door open (Cars conforming to a North American specification)
 - 5 Rear fog lamps (if fitted)
- F**
- 1 Fan speed 1
 - 2 Fan speed 2
 - 3 Fan speed 3
 - 4 Fan speed 4
 - 5 Water tap
 - 6 Compressor clutch
 - 7 Headlamps flash
 - 8 Fans control
 - 9 Air horns (if fitted)
 - 10 Windtone horns
 - 11 Engine cooling fans

- G**
- 1 Headlamps sequencing
 - 2 Anti-lock braking system modulator (Cars other than those conforming to a Japanese or North American specification)

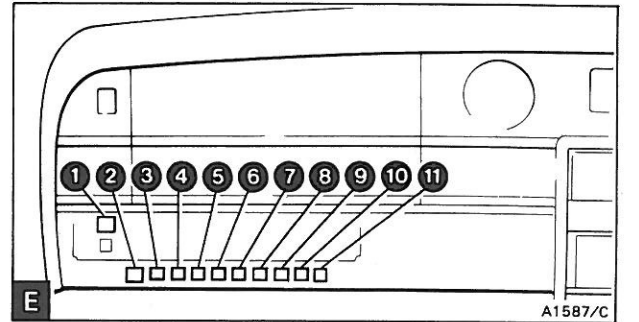
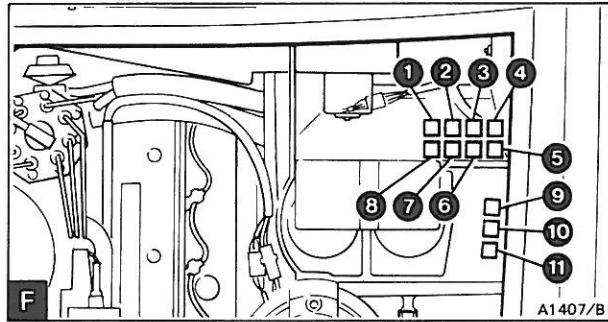
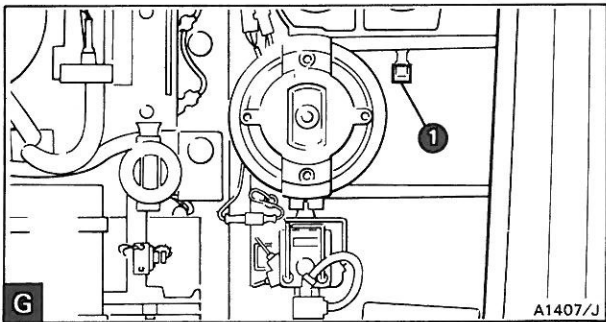
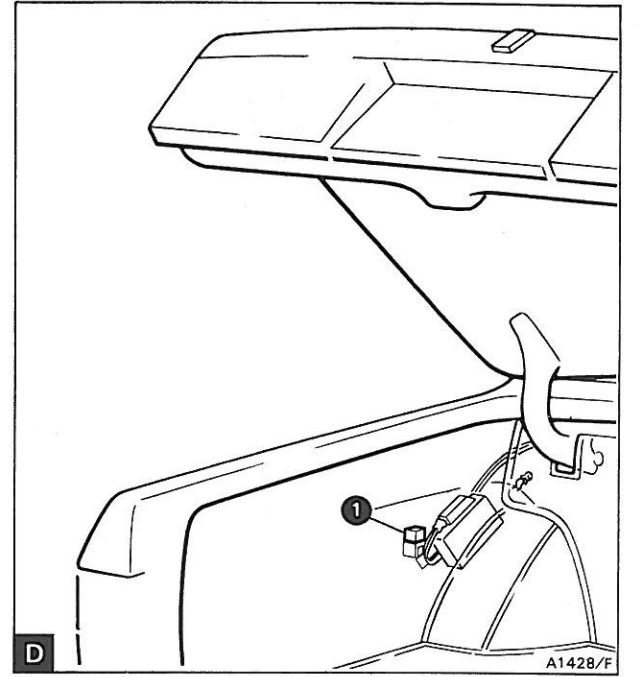
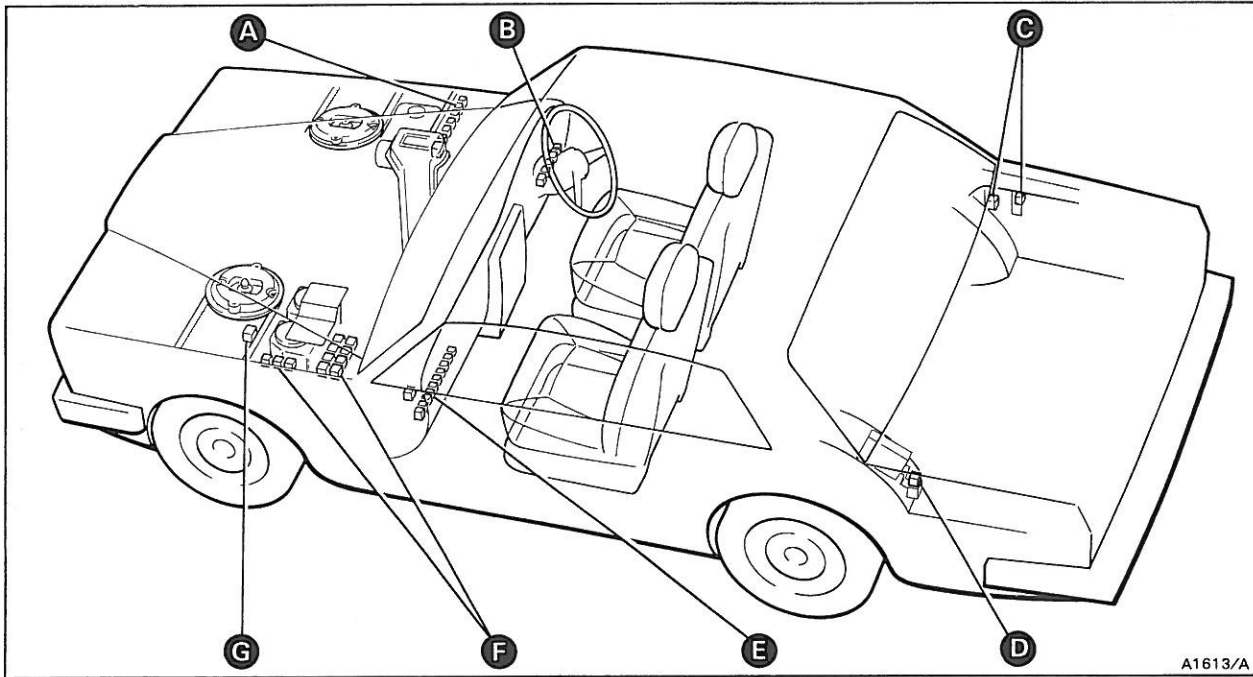
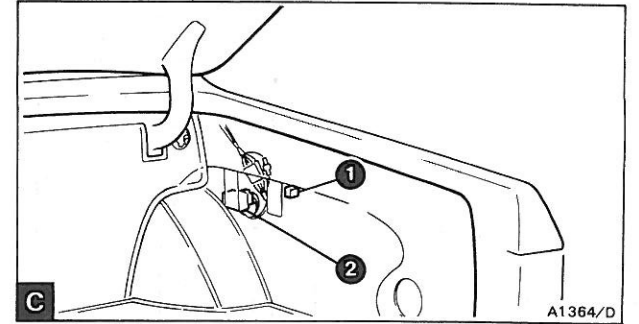
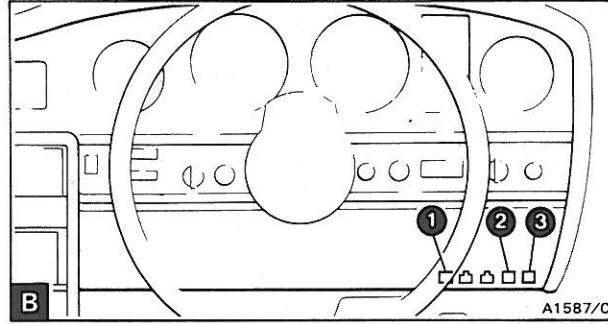
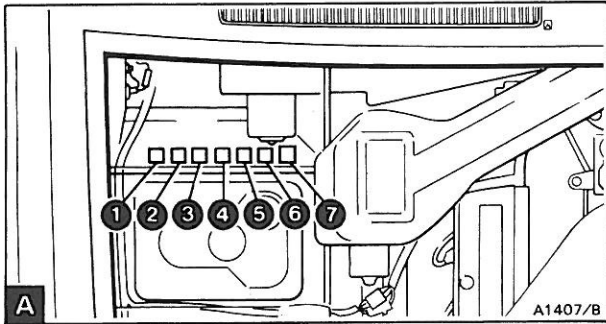

Key to 4-5

- A**
- 1 Windscreen wipers 1
 - 2 Windscreen wipers 2
 - 3 Windscreen wipers 3
 - 4 Starter
 - 5 Starter inhibit
 - 6 Kick-down (Turbocharged cars and cars fitted with a catalytic converter)
 - 7 Fuel injection control (Turbocharged cars only)

- B**
- 1 Rear fog lamps (if fitted)
 - 2 Window lifts (Cars conforming to an Australian specification)
- Note** On cars conforming to a Japanese or United Kingdom specification, the relay is not fitted and the black and black/slate cables are interlinked at the relay base
- 3 Heaters inhibit

- C**
- 1 Rear window demister
 - 2 Stop lamp failure

- D**
- 1 Anti-lock braking system modulator

- E**
- 1 Anti-lock braking system
 - 2 Headlamps power wash timer
 - 3 Cranking interlock
 - 4 Radio
 - 5 Fuel filler door
 - 6 Warning lamps dimming
 - 7 Warning lamps test
 - 8 Centralized door locking unlock
 - 9 Centralized door locking lock
 - 10 Headlamps relay 1
 - 11 Headlamps relay 2 – dim/dip facility
- Note** On right-hand drive cars other than those fitted with headlamps dim/dip facility, the relay is not fitted and terminals 2 and 8 are interlinked at the relay base

- F**
- 1 Fan speed 1
 - 2 Fan speed 2
 - 3 Fan speed 3
 - 4 Fan speed 4
 - 5 Water tap
 - 6 Compressor clutch
 - 7 Headlamps flash
 - 8 Fans control
 - 9 Air horns (if fitted)
 - 10 Windtone horns
 - 11 Engine cooling fans

- G**
- 1 Headlamps sequencing

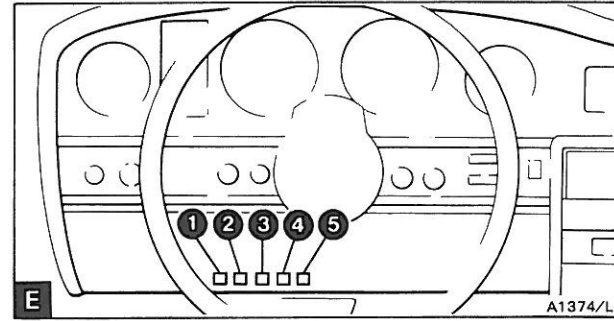
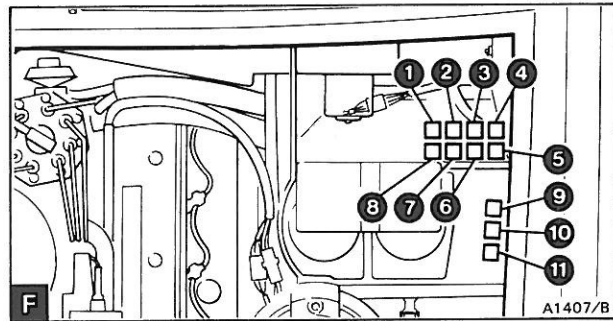
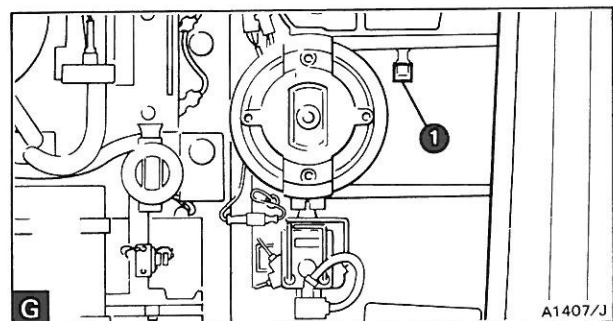
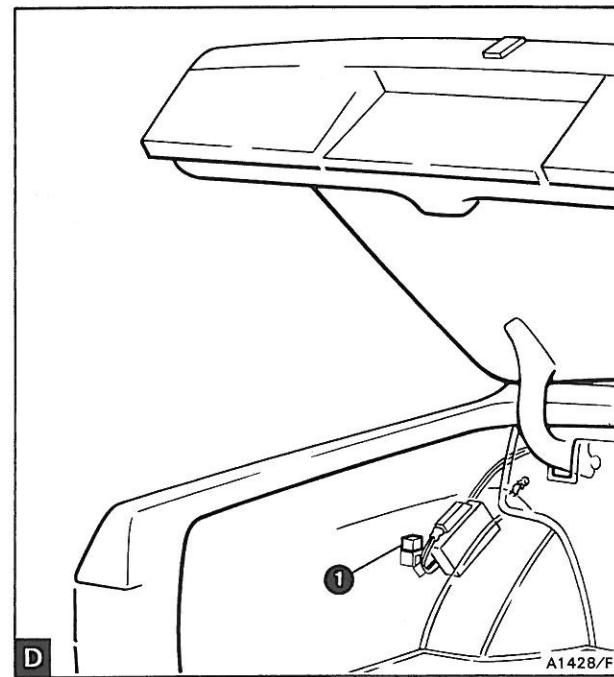
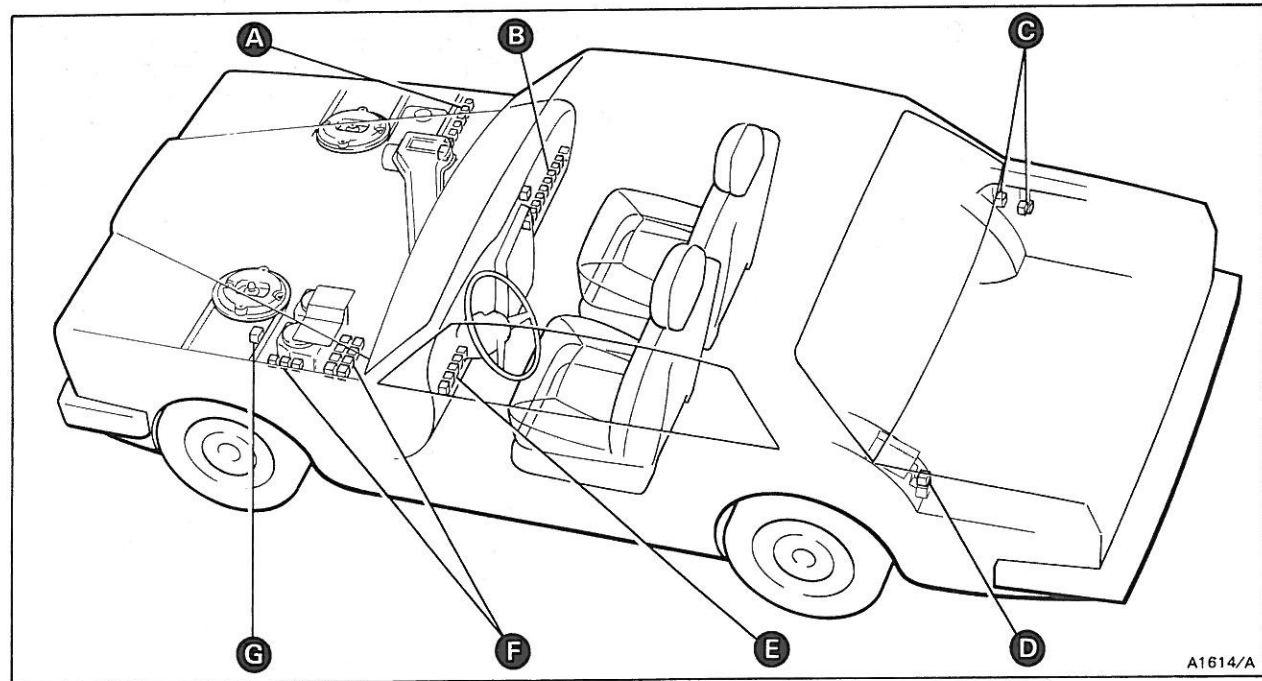
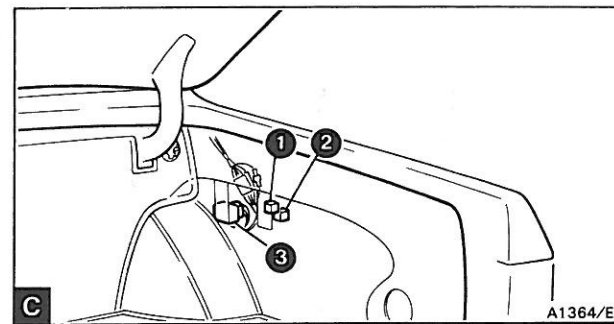
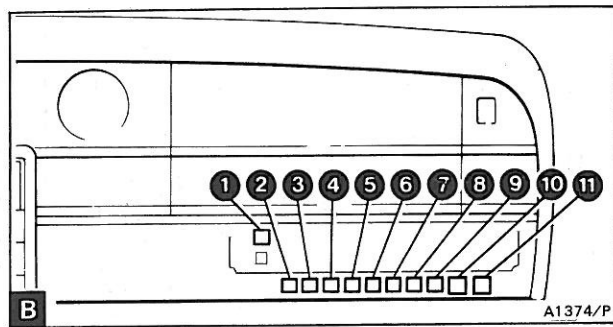
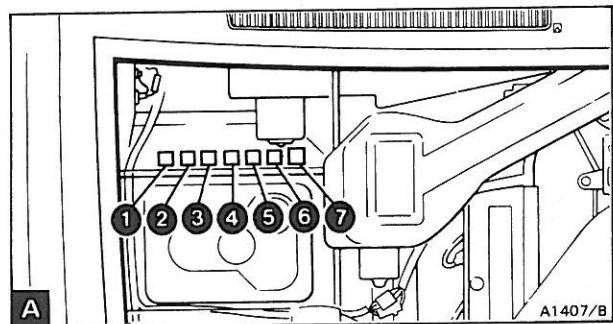

Key to 4-6

- A**
- 1 Windscreen wipers 1
 - 2 Windscreen wipers 2
 - 3 Windscreen wipers 3
 - 4 Starter
 - 5 Starter inhibit
 - 6 Kick-down (Turbocharged cars and cars fitted with a catalytic converter)
 - 7 Fuel injection control (Turbocharged cars only)
- B**
- 1 Anti-lock braking system
 - 2 Headlamps relay 1
 - 3 Centralized door locking lock
 - 4 Centralized door locking unlock
 - 5 Warning lamps test
 - 6 Warning lamps dimming
 - 7 Fuel filler door
 - 8 Radio
 - 9 Cranking interlock
 - 10 Headlamps power wash timer (Cars other than those fitted with passive restraint – seat belts)
 - 11 Headlamps power wash timer (Cars fitted with passive restraint – seat belts)
- C**
- 1 High mounted stop lamp (Cars conforming to a North American specification)
 - 2 Rear window demister
 - 3 Stop lamp failure
- D**
- 1 Anti-lock braking system modulator

- E**
- 1 Heaters inhibit
 - 2 Window lifts (Cars conforming to a European or North American specification)
Note On cars conforming to a Japanese specification, the relay is not fitted and the black and black/slate cables are interlinked at the relay base
 - 3 Window lifts latch (Cars conforming to a North American specification)
 - 4 Driver's door open (Cars conforming to a North American specification)
 - 5 Rear fog lamps (if fitted)
- F**
- 1 Fan speed 1
 - 2 Fan speed 2
 - 3 Fan speed 3
 - 4 Fan speed 4
 - 5 Water tap
 - 6 Compressor clutch
 - 7 Headlamps flash
 - 8 Fans control
 - 9 Air horns (if fitted)
 - 10 Windtone horns
 - 11 Engine cooling fans

- G**
- 1 Headlamps sequencing

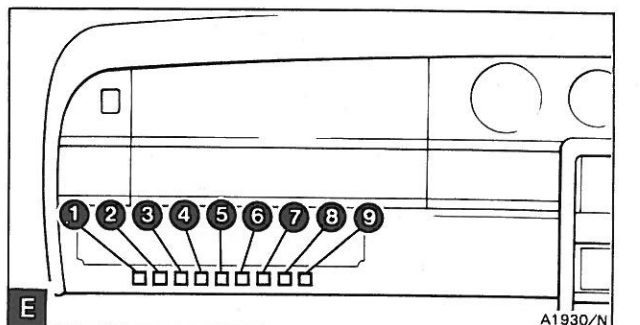
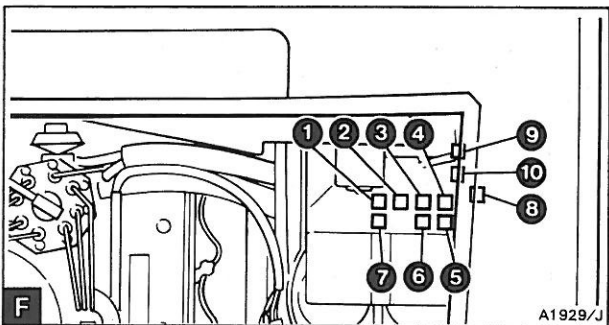
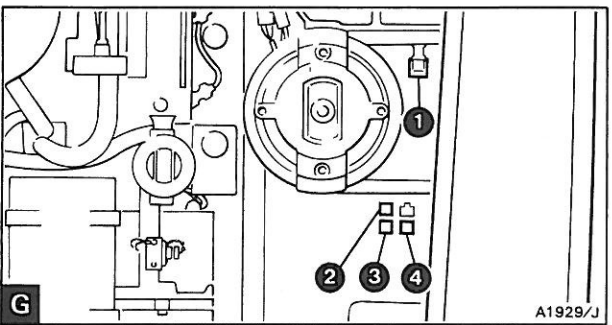
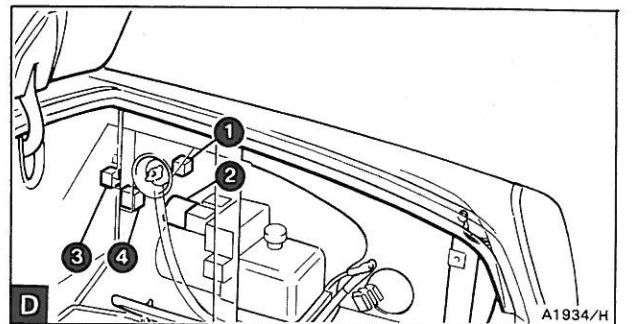
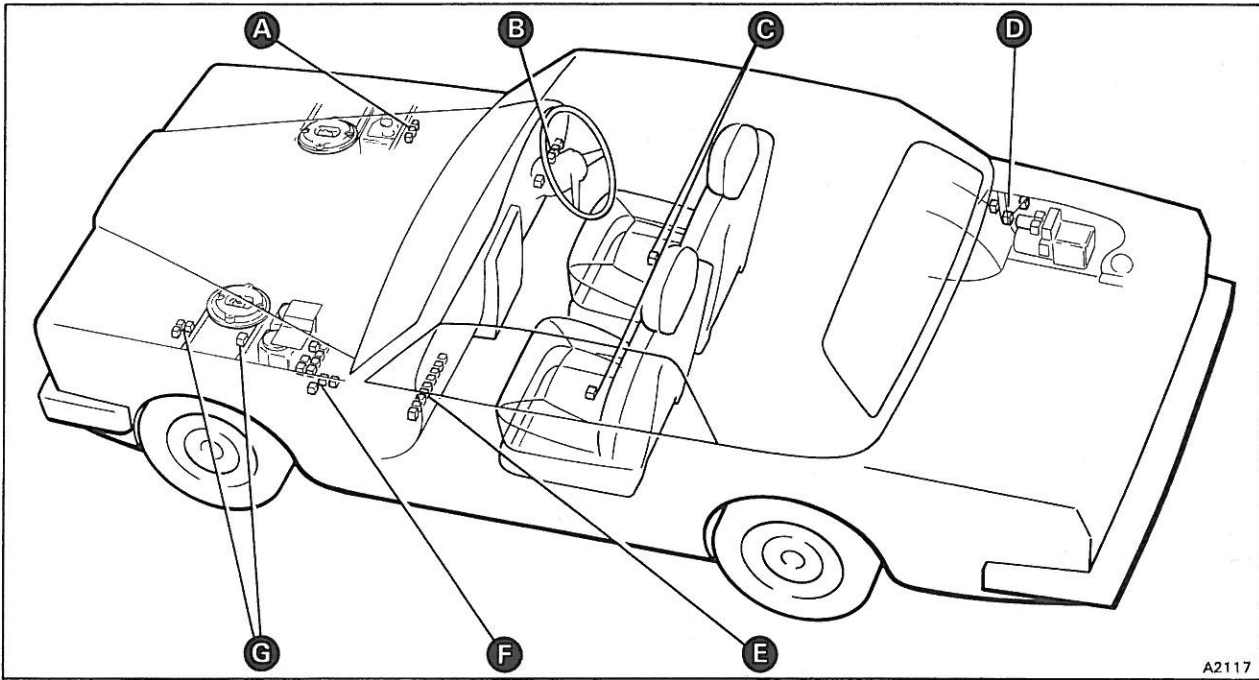
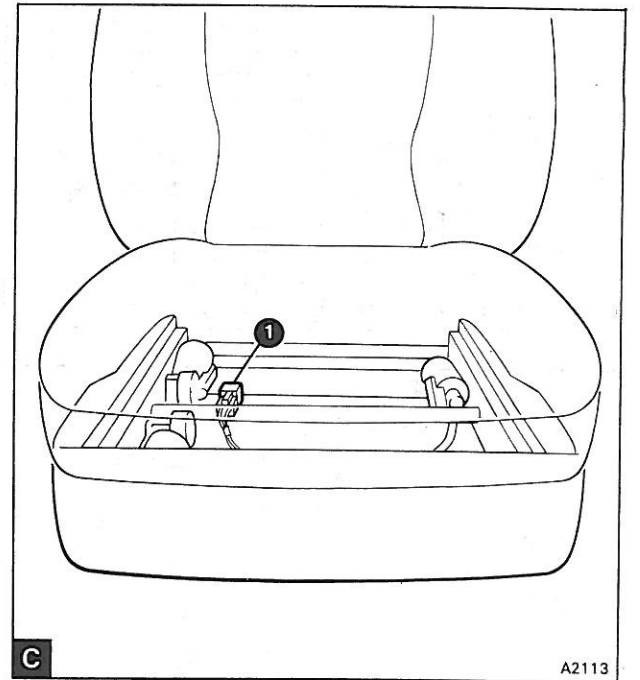
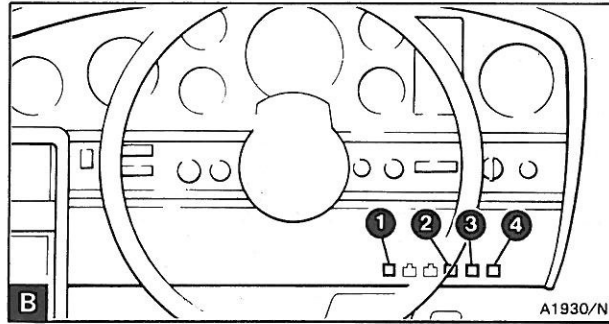
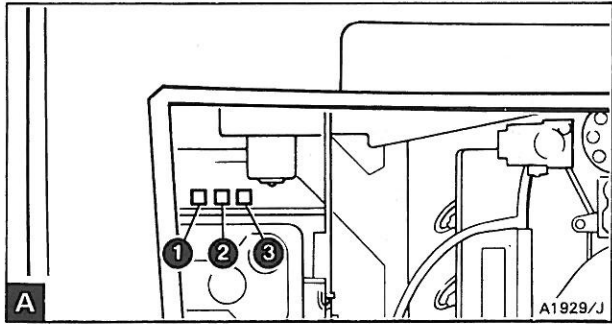

Key to 4-7

- A**
- 1 Air horns (when fitted)
 - 2 Starter
 - 3 Starter inhibit
- B**
- 1 Rear fog lamps
 - 2 Window lifts (*Cars other than those conforming to a United Kingdom specification*)
- Note** On cars conforming to a United Kingdom specification, the relay is not fitted and the black and black/slate cables are interlinked at the relay base
- 3 Heaters inhibit
 - 4 Mirror heaters
- C**
- 1 Front seats
- D**
- 1 Hood lift control
 - 2 Hood lift motor
 - 3 Auxiliary start
 - 4 Stop lamp failure
- E**
- 1 Cranking interlock
 - 2 Radio
 - 3 Fuel filler door
 - 4 Warning lamps dimming
 - 5 Warning lamps test
 - 6 Centralized door locking unlock
 - 7 Centralized door locking lock
 - 8 Headlamps relay 1
 - 9 Headlamps relay 2 — dim/dip facility
- Note** On right-hand drive cars other than those fitted with headlamps dim/dip facility, the relay is not fitted and terminals 2 and 8 are interlinked at the relay base.

- F**
- 1 Fan speed 1
 - 2 Fan speed 2
 - 3 Fan speed 3
 - 4 Fan speed 4
 - 5 Water tap
 - 6 Compressor clutch
 - 7 Fans control
 - 8 Windscreen wipers 1
 - 9 Windscreen wipers 2
 - 10 Windscreen wipers 3
- G**
- 1 Headlamps sequencing
 - 2 Windtone horns
 - 3 Headlamps flash
 - 4 Auxiliary cooling fans

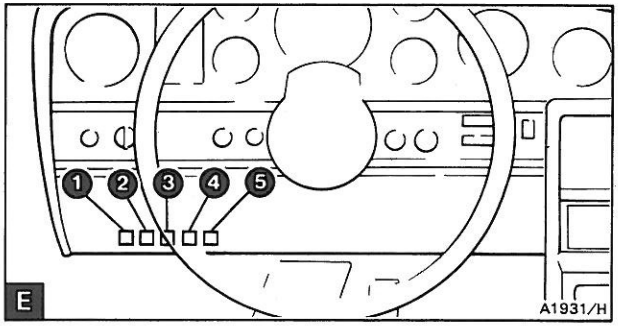
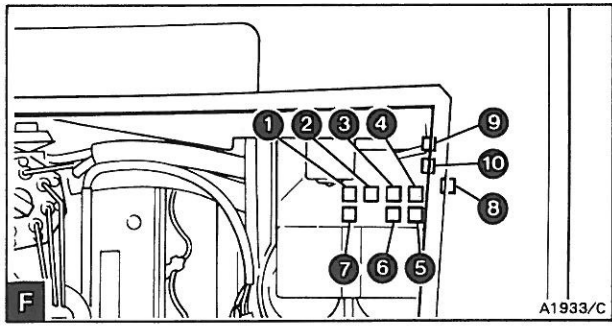
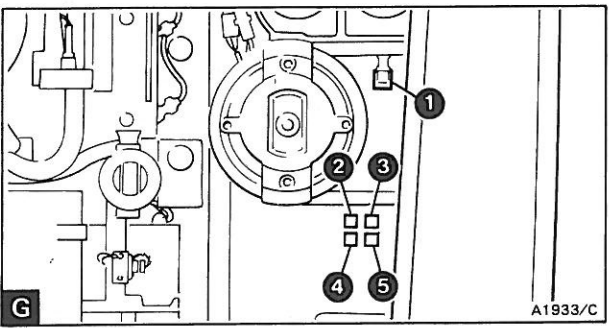
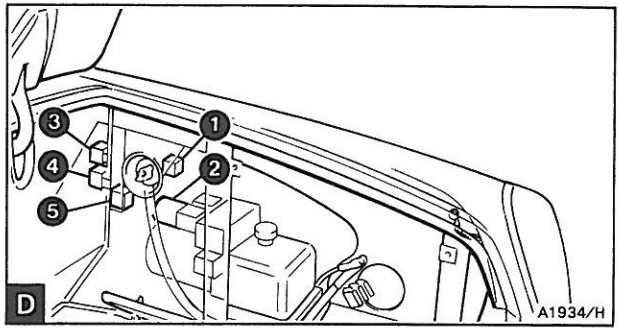
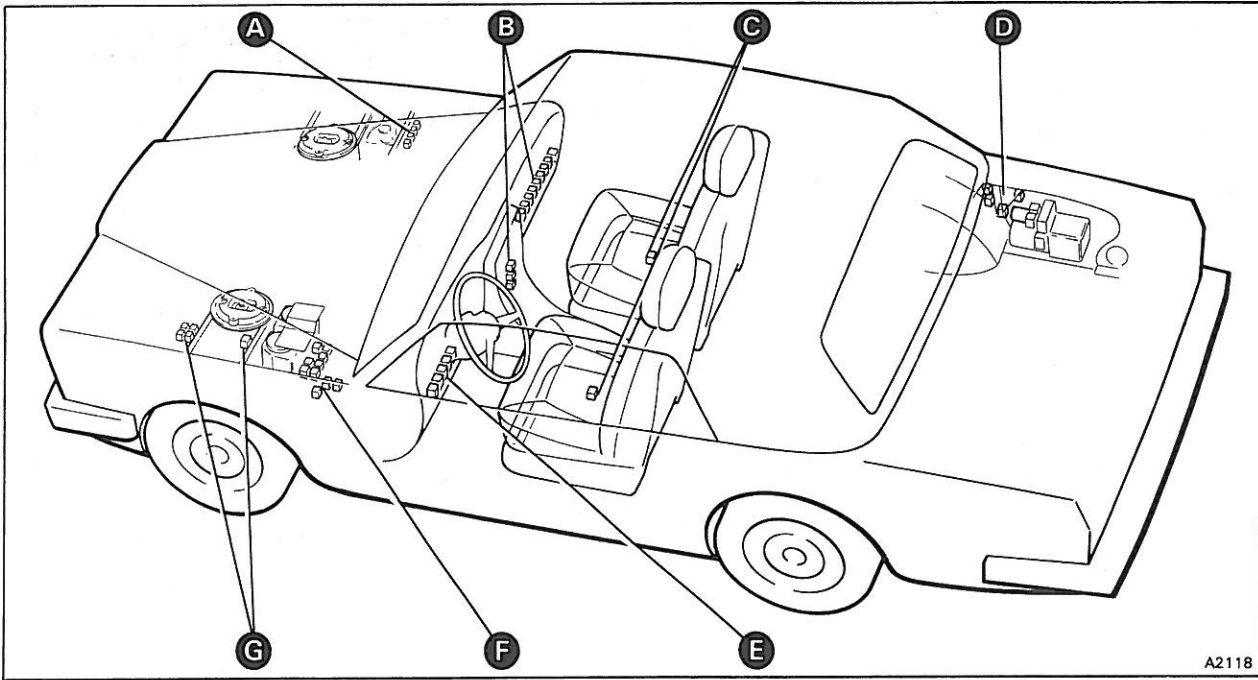
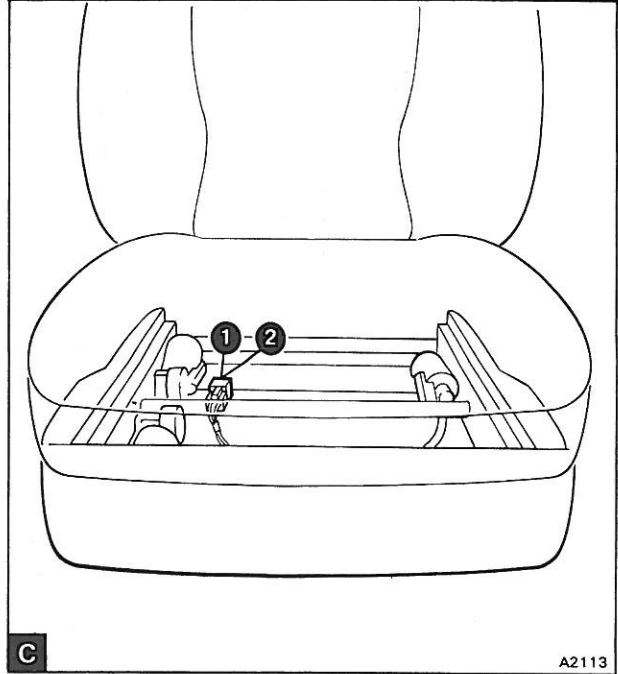
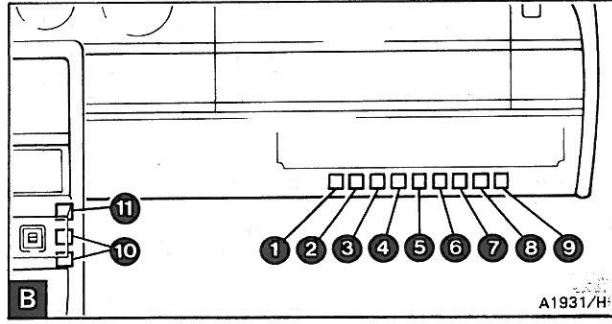
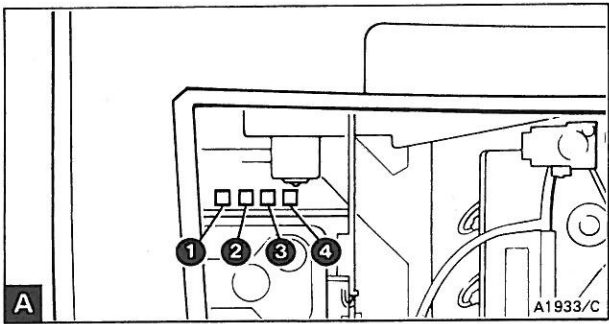

Key to 4-8

- A**
- 1 Air horns (when fitted)
 - 2 Starter
 - 3 Starter inhibit
 - 4 Kick-down (Cars conforming to a North American specification)
- B**
- 1 Headlamps relay 1
 - 2 Centralized door locking lock
 - 3 Centralized door locking unlock
 - 4 Warning lamps dimming
 - 5 Warning lamps test
 - 6 Fuel filler door
 - 7 Radio
 - 8 Cranking interlock
 - 9 Mirror heaters
 - 10 Front seats (Cars fitted with seat memory facility)
 - 11 Rear windows isolation (Cars conforming to a North American specification)
- C**
- 1 Front seats stop (Cars fitted with seat memory facility)
 - 2 Front seats (Cars other than those fitted with seat memory facility)
- D**
- 1 Hood lift control
 - 2 Hood lift motor
 - 3 High mounted stop lamp (Cars conforming to a North American specification)
 - 4 Auxiliary start
 - 5 Stop lamp failure
- E**
- 1 Heaters inhibit
 - 2 Window lifts (Cars conforming to a European or North American specification)
 - 3 Window lifts latch (Cars conforming to a North American specification)
 - 4 Driver's door open (Cars conforming to a North American specification)
 - 5 Rear fog lamps (when fitted)

- F**
- 1 Fan speed 1
 - 2 Fan speed 2
 - 3 Fan speed 3
 - 4 Fan speed 4
 - 5 Water tap
 - 6 Compressor clutch
 - 7 Fans control
 - 8 Windscreen wipers 1
 - 9 Windscreen wipers 2
 - 10 Windscreen wipers 3
- G**
- 1 Headlamps sequencing
 - 2 Windtone horns
 - 3 Telephone auxiliary alert (Cars conforming to a North American specification)
 - 4 Headlamps flash
 - 5 Auxiliary cooling fans

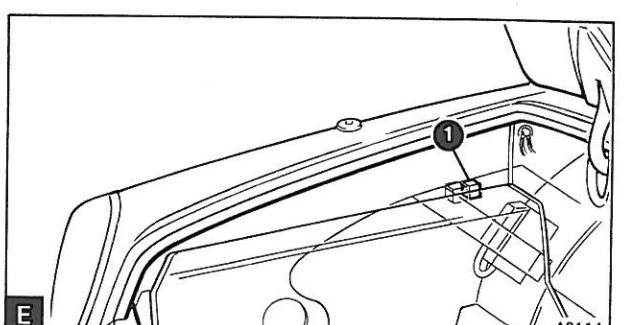
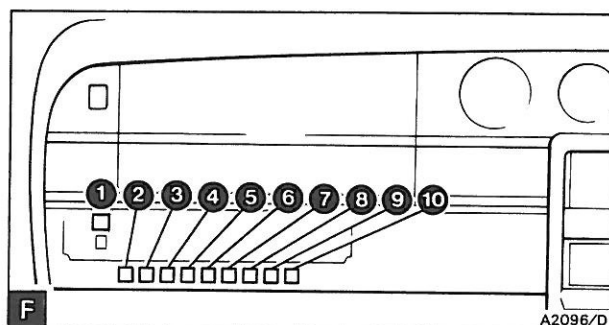
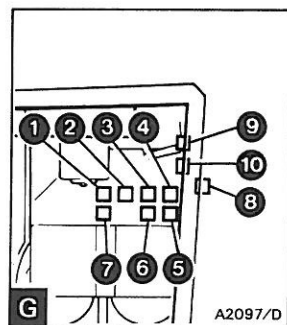
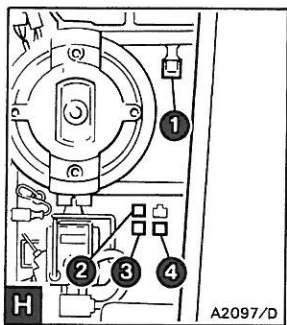
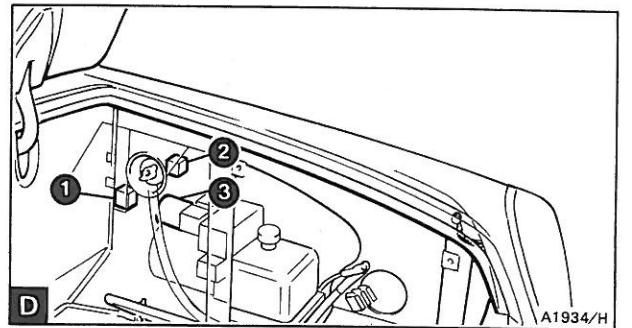
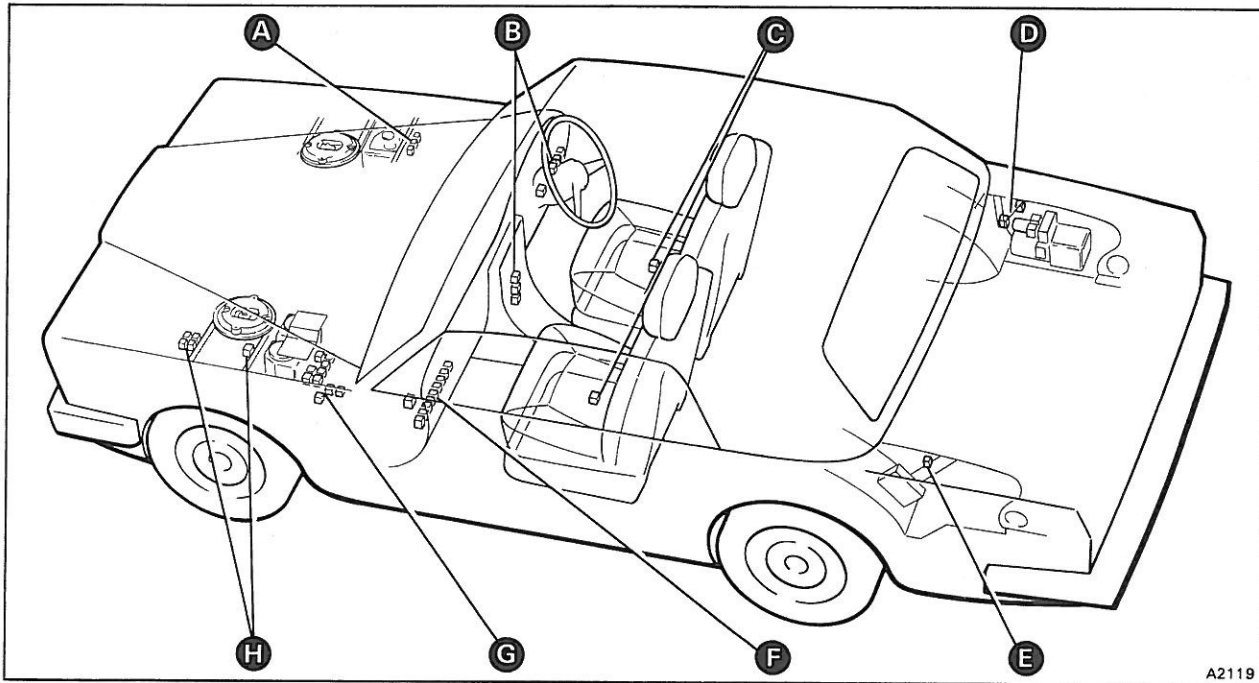
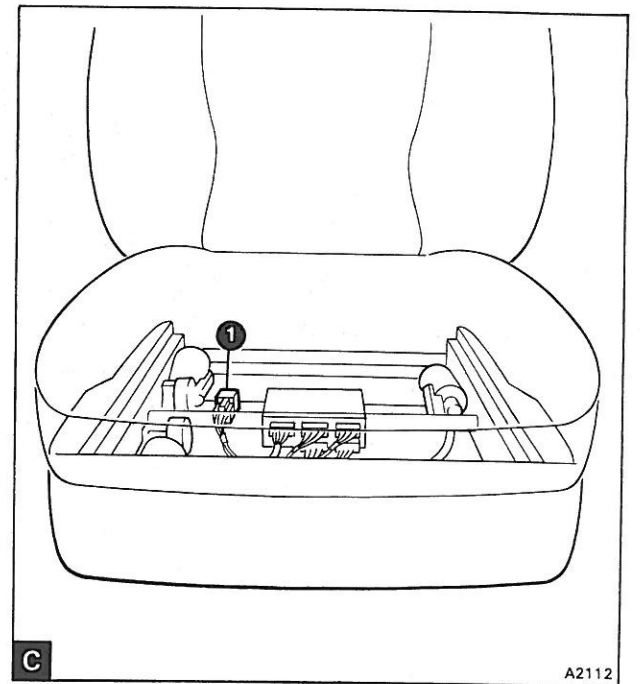
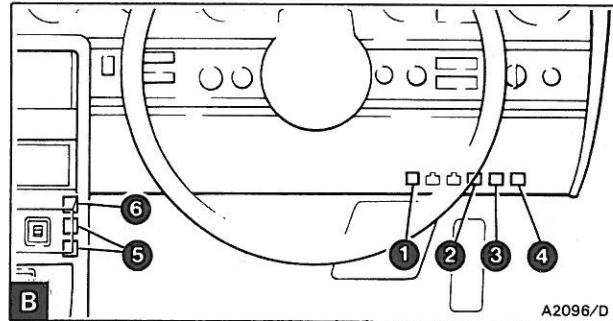
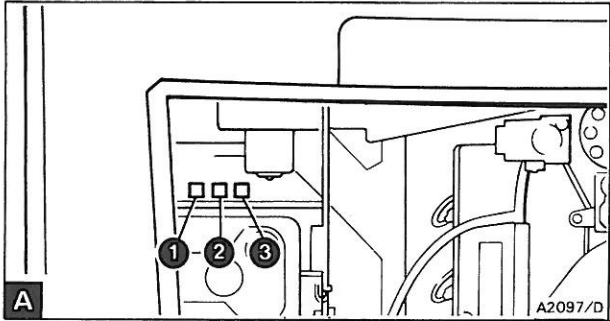

Key to 4-9

- A**
- 1 Air horns (when fitted)
 - 2 Starter
 - 3 Starter inhibit
- B**
- 1 Rear fog lamps
 - 2 Window lifts (*Cars other than those conforming to a United Kingdom specification*)
 - Note** *On cars conforming to a United Kingdom specification, the relay is not fitted and the black and black/slate cables are interlinked at the relay base*
 - 3 Heaters inhibit
 - 4 Mirror heaters
 - 5 Front seats
 - 6 Rear windows isolation
- C**
- 1 Front seats stop
- D**
- 1 Stop lamp failure
 - 2 Hood lift control
 - 3 Hood lift motor
- E**
- 1 Anti-lock braking system modulator
- F**
- 1 Anti-lock braking system
 - 2 Cranking interlock
 - 3 Radio
 - 4 Fuel filler door
 - 5 Warning lamps dimming
 - 6 Warning lamps test
 - 7 Centralized door locking unlock
 - 8 Centralized door locking lock
 - 9 Headlamps relay 1
 - 10 Headlamps relay 2 – dim/dip facility
 - Note** *On right-hand drive cars other than those fitted with headlamps dim/dip facility, the relay is not fitted and terminals 2 and 8 are interlinked at the relay base*

- G**
- 1 Fan speed 1
 - 2 Fan speed 2
 - 3 Fan speed 3
 - 4 Fan speed 4
 - 5 Water tap
 - 6 Compressor clutch
 - 7 Fans control
 - 8 Windscreen wipers 1
 - 9 Windscreen wipers 2
 - 10 Windscreen wipers 3
- H**
- 1 Headlamps sequencing
 - 2 Windtone horns
 - 3 Headlamps flash
 - 4 Auxiliary cooling fans

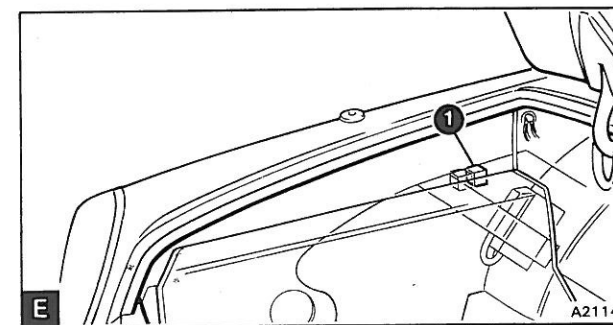
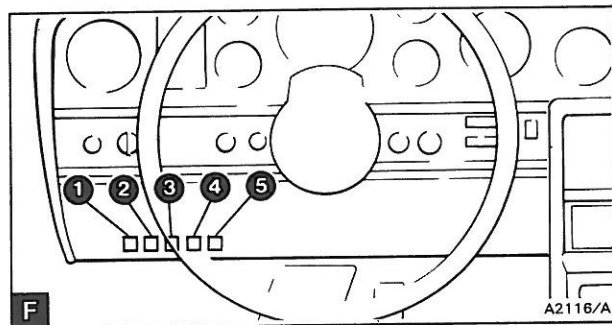
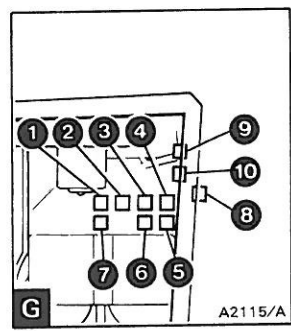
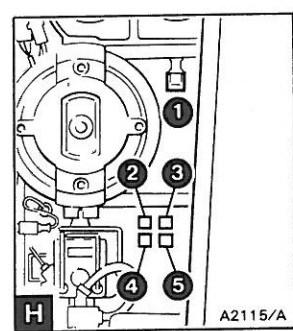
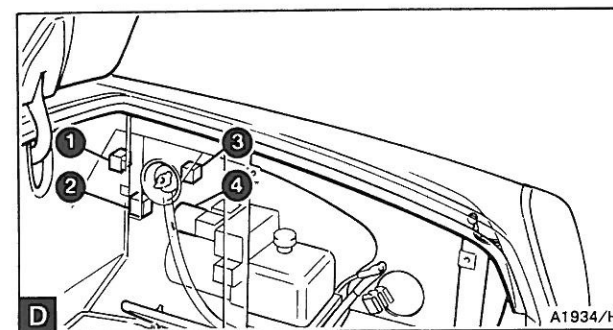
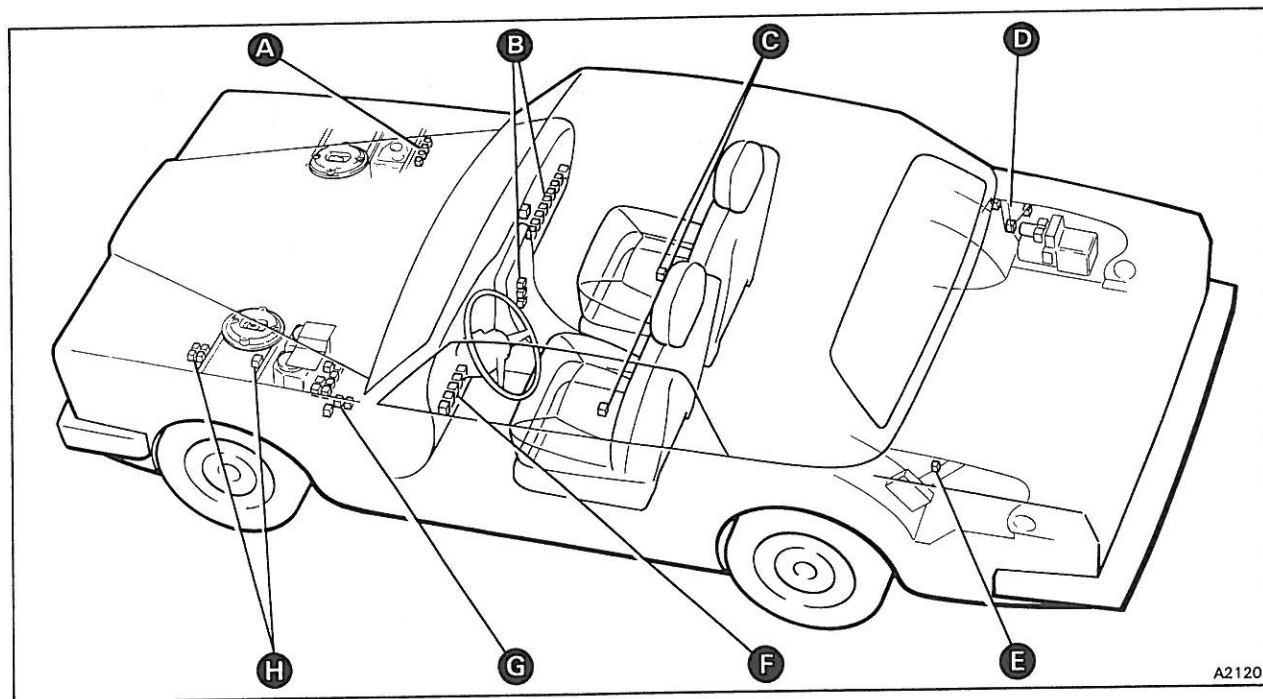
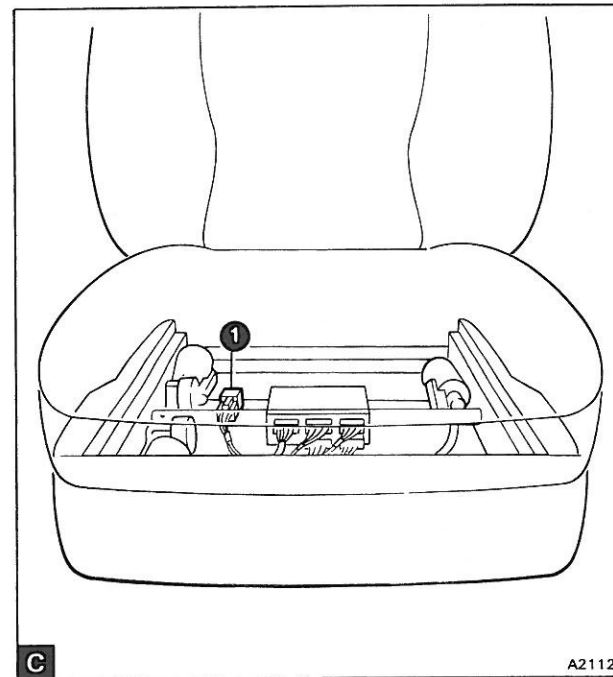
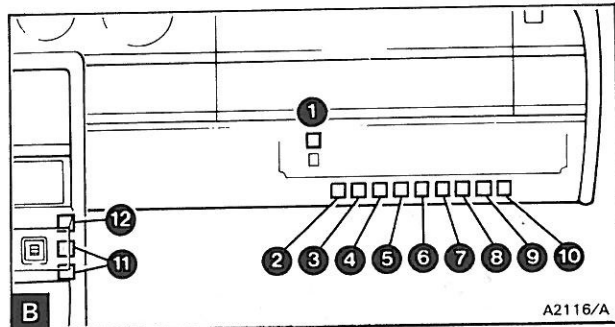
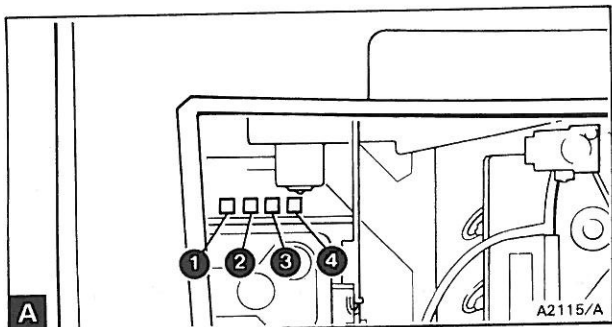

Key to 4-10

- A**
- 1 Air horns (when fitted)
 - 2 Starter
 - 3 Starter inhibit
 - 4 Kick-down (Cars fitted with a catalytic converter)
- B**
- 1 Anti-lock braking system
 - 2 Headlamps relay 1
 - 3 Centralized door locking lock
 - 4 Centralized door locking unlock
 - 5 Warning lamps dimming
 - 6 Warning lamps test
 - 7 Fuel filler door
 - 8 Radio
 - 9 Cranking interlock
 - 10 Mirror heaters
 - 11 Front seats
 - 12 Rear windows isolation
- C**
- 1 Front seats stop
- D**
- 1 High mounted stop lamp (Cars conforming to a North American specification)
 - 2 Stop lamp failure
 - 3 Hood lift control
 - 4 Hood lift motor
- E**
- 1 Anti-lock braking system modulator
- F**
- 1 Heaters inhibit
 - 2 Window lifts (Cars conforming to a European or North American specification)
 - 3 Window lifts latch (Cars conforming to a North American specification)
 - 4 Driver's door open (Cars conforming to a North American specification)
 - 5 Rear fog lamps (when fitted)
- G**
- 1 Fan speed 1
 - 2 Fan speed 2
 - 3 Fan speed 3
 - 4 Fan speed 4
 - 5 Water tap
 - 6 Compressor clutch
 - 7 Fans control
 - 8 Windscreen wipers 1
 - 9 Windscreen wipers 2
 - 10 Windscreen wipers 3
- H**
- 1 Headlamps sequencing
 - 2 Windtone horns
 - 3 Telephone auxiliary alert (Cars conforming to a North American specification)
 - 4 Headlamps flash
 - 5 Auxiliary cooling fans