

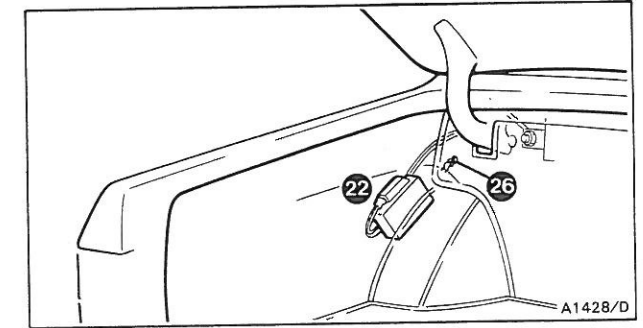

Braking systems

Contents	Specific application	Pages							
		Rolls-Royce			Bentley				
		Silver Spirit	Silver Spur	Corniche / Corniche II	Eight	Mulsanne	Mulsanne S	Turbo R	Continental
Cars fitted with anti-lock braking system									
Anti-lock braking system									
Component location	1987 model year cars	9-2	9-2	—	9-2	9-2	—	9-2	—
Wiring diagram		9-3	9-3	—	9-3	9-3	—	9-3	—
Component location	1988 model year cars	9-8	9-8	9-8	9-8	—	9-8	9-8	9-8
Wiring diagram		9-9	9-9	9-9	9-9	—	9-9	9-9	9-9
Test procedure	Refer to Workshop Manual TSD 4700 Chapter G								
Brake pressure warning lamps and test circuits									
Component location	1987 model year cars	9-4	9-4	—	9-4	9-4	—	9-4	—
Wiring diagram		9-4	9-4	—	9-4	9-4	—	9-4	—
Component location	1988 model year cars	9-14	9-14	9-14	9-14	—	9-14	9-14	9-14
Wiring diagram		9-14	9-14	9-14	9-14	—	9-14	9-14	9-14
Brake pad wear, parking brake warning, lamps and test circuits									
Component location	1987 model year cars	9-6	9-6	—	9-6	9-6	—	9-6	—
Wiring diagram		9-6	9-6	—	9-6	9-6	—	9-6	—
Component location	1988 model year cars	9-10	9-10	9-12	9-10	—	9-10	9-10	9-12
Wiring diagram		9-11	9-11	9-13	9-11	—	9-11	9-11	9-13
Cars other than those fitted with anti-lock braking system									
Brake pressure warning lamps and test circuits									
Component location	1987 model year cars	9-5	9-5	9-5	9-5	9-5	—	9-5	9-5
Wiring diagram		9-5	9-5	9-5	9-5	9-5	—	9-5	9-5
Brake pad wear, parking brake warning, lamps and test circuits									
Component location	1987 model year cars	9-6	9-6	9-7	9-6	9-6	—	9-6	9-7
Wiring diagram		9-6	9-6	9-7	9-6	9-6	—	9-6	9-7

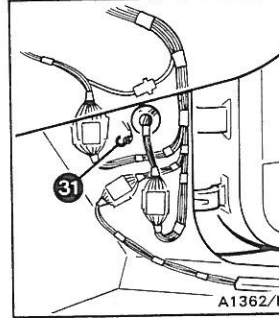
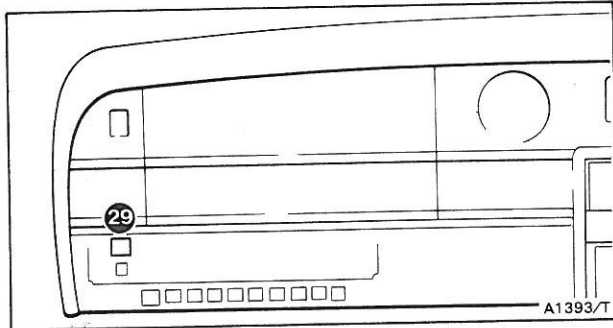
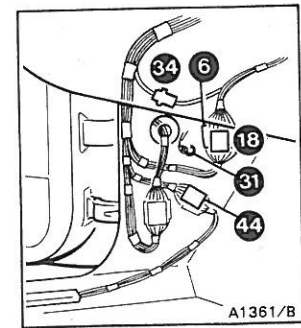
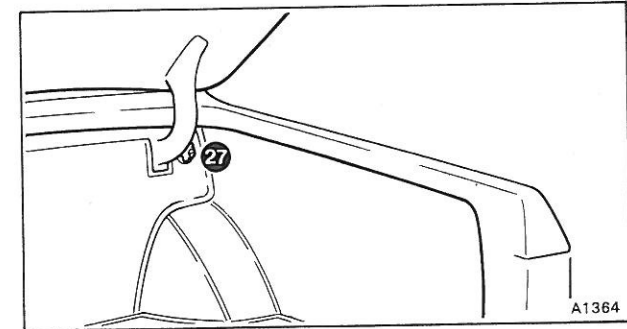
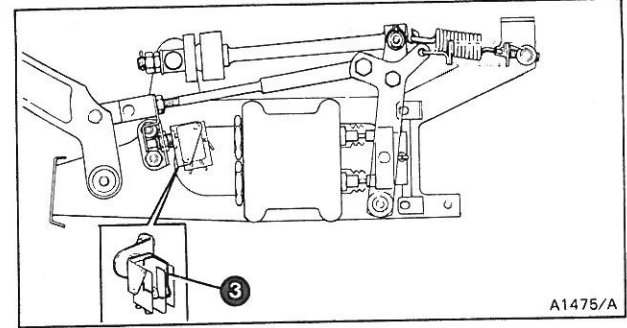
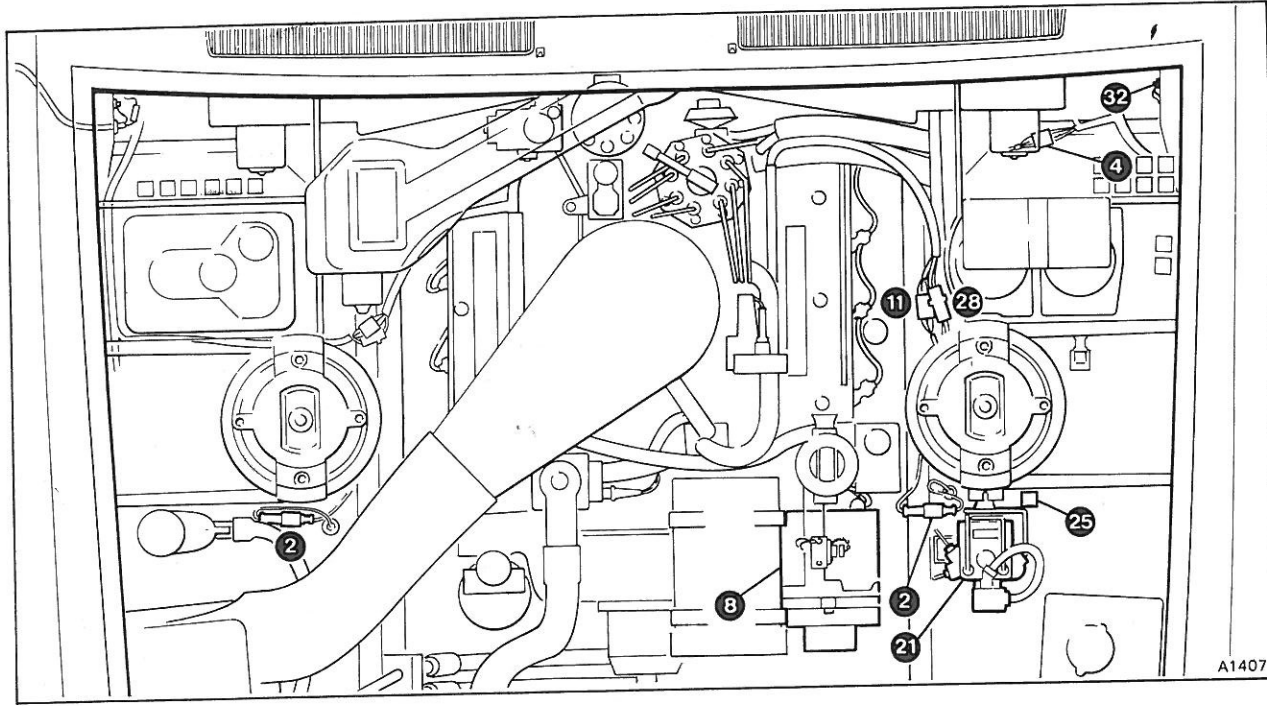
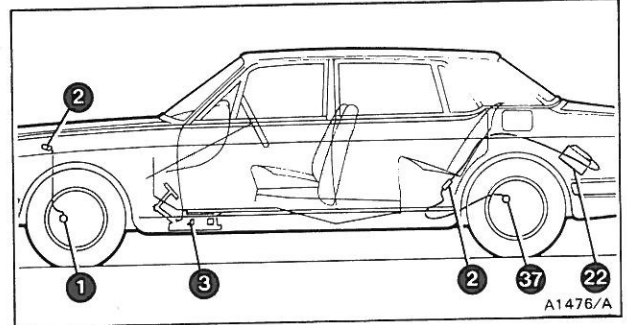
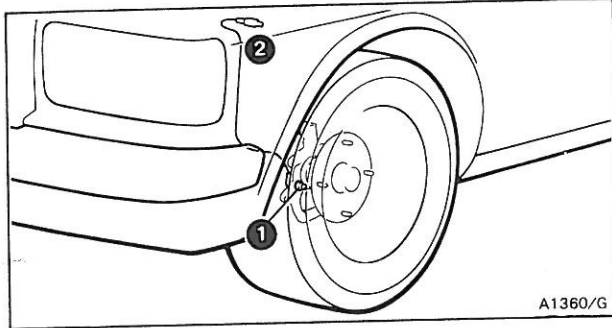
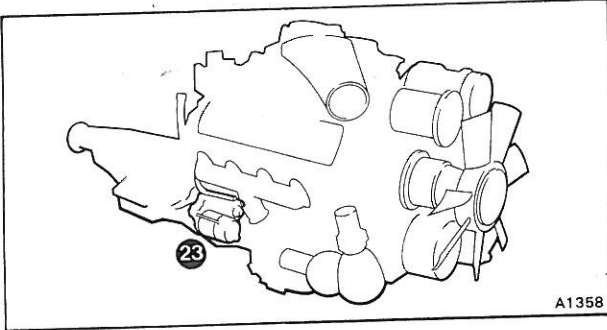

Key to 9-3

- 1 Left-hand front wheel sensor
- 2 Wheel speed sensor plug and socket
- 3 Stop lamps switch
- 4 Brake switch loom plug and socket
- 5 Splice A

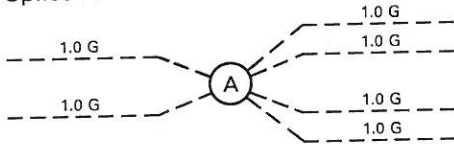

- 6 Left-hand main to valance loom plug and socket 7-way
- 7 Right-hand front wheel sensor
- 8 Alternator
- 9 Fusible link (at alternator)
- 10 Splice D

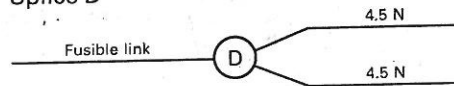

- 11 Left-hand valance to engine loom plug and socket 9-way
- 12 Splice E

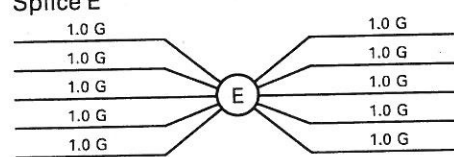

- 13 Splice F

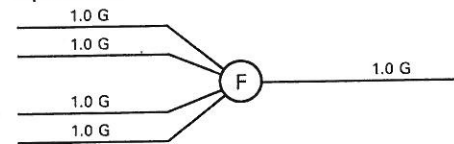

- 14 Splice B

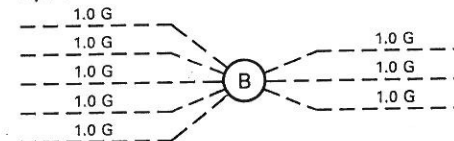

- 15 Splice C

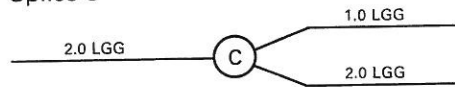

- 16 Fuseboard F1, fuse B4, 10 Amp
- 17 Fuseboard F2, fuse B3, 20 Amp
- 18 Left-hand main to valance loom plug and socket 12-way
- 19 Splice G

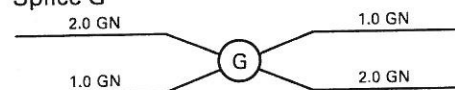

- 20 Anti-lock braking system warning lamp
- 21 Hydraulic modulator valves
- 22 Anti-lock braking system electronic control unit
- 23 Starter motor
- 24 Splice H

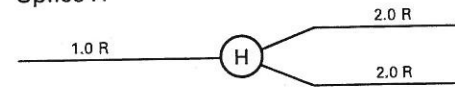

- 25 Modulator relay
- 26 Luggage compartment earth point - left-hand
- 27 Battery master switch (Cars other than those conforming to a West German specification)
- 28 Left-hand valance to engine loom 60 Amp connector
- 29 Anti-lock braking system relay and fuse
- 30 Splice J

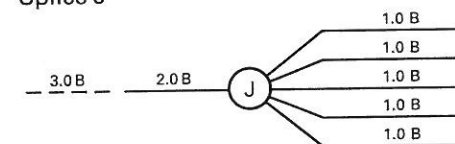

- 31 'A' post earth points
- 32 Left-hand valance earth point
- 33 Battery
- 34 Left-hand main to valance loom 60 Amp connector

- 35 Splice K

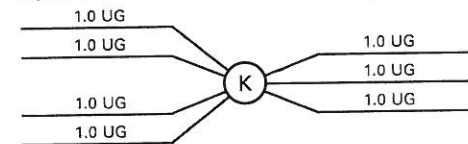

- 36 Fuseboard F1, fuse B2, 10 Amp
- 37 Left-hand rear wheel sensor
- 38 Battery earth point
- 39 Splice L

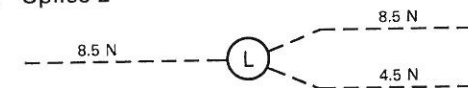

- 40 Splice M

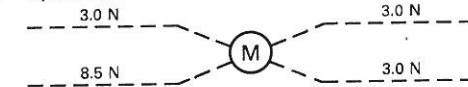

- 41 Splice N Right-hand drive

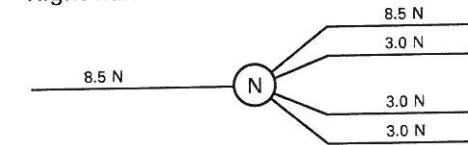

Left-hand drive

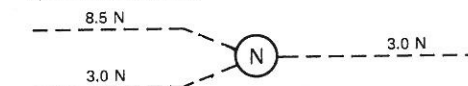

- 42 Splice O

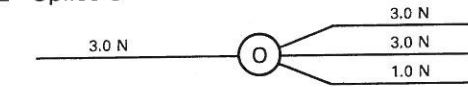

- 43 Right-hand rear wheel sensor
- 44 Anti-lock braking system plug and socket 5-way

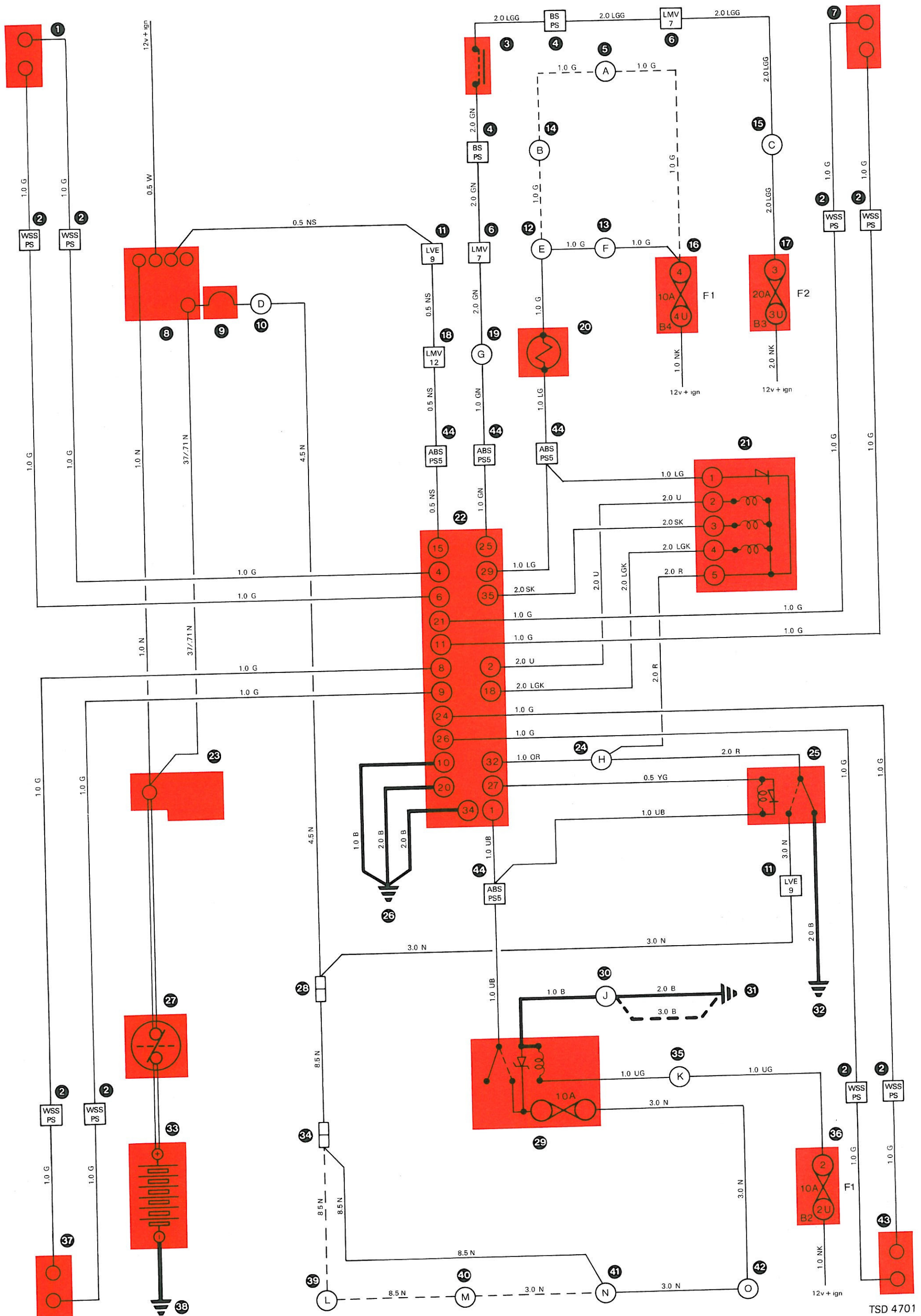

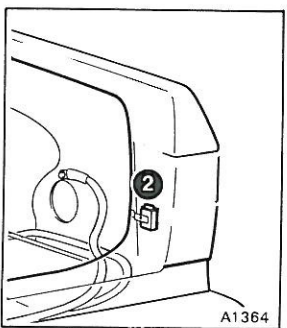
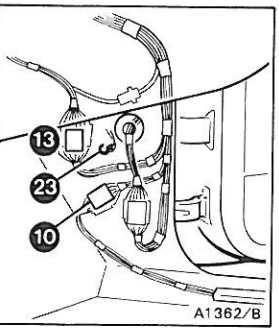
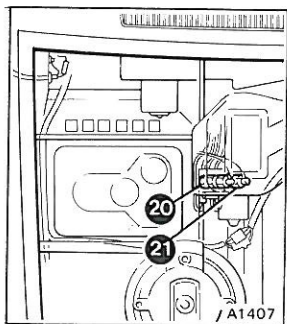
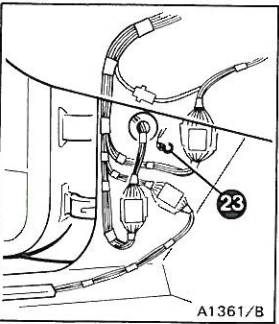
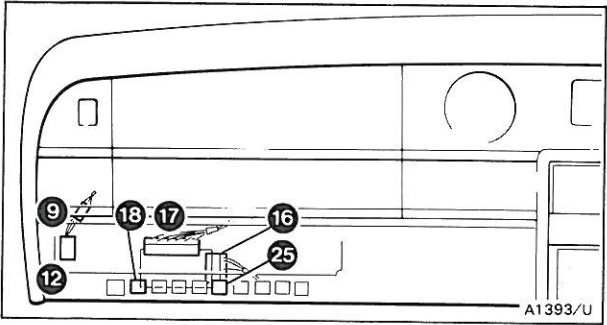
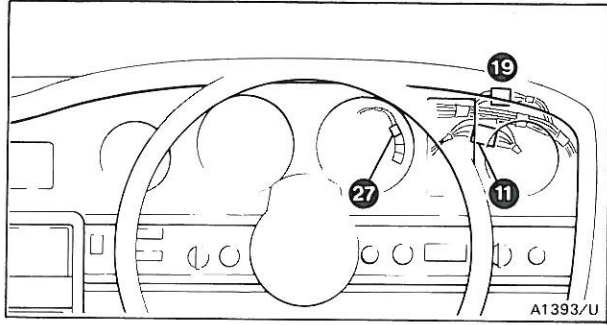

Key to 9-4

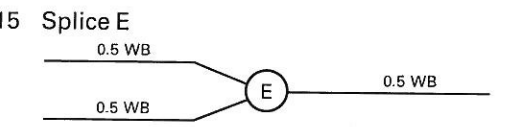
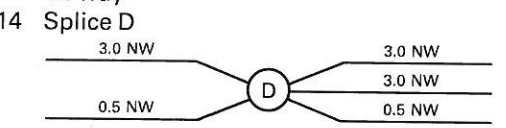
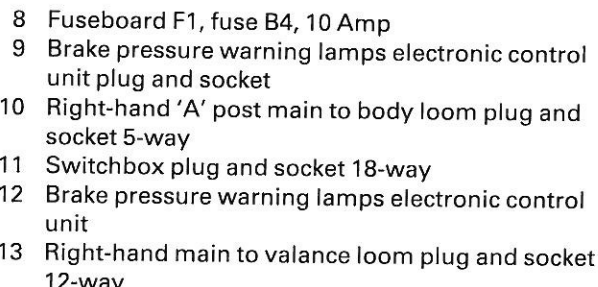
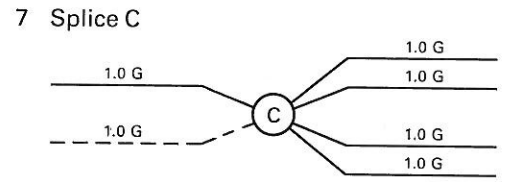
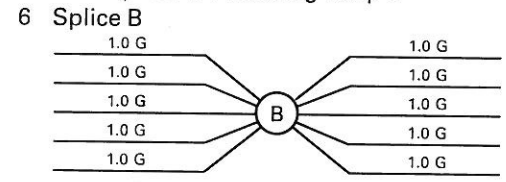
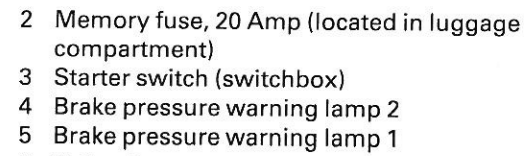
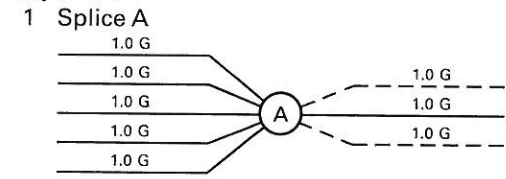

- 16 Diode board plug 10-way
- 17 Diode board plug 18-way
- 18 Cranking interlock relay
- 19 'Other than Europe' plug and socket
- 20 Brake pressure switch 2
- 21 Brake pressure switch 1
- 22 Splice F

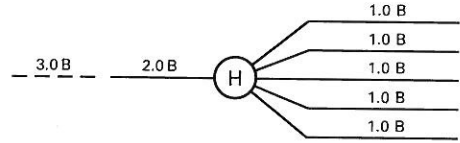
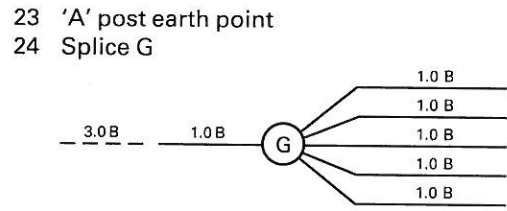
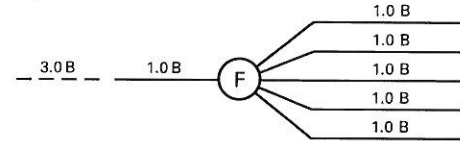

- 27 Speedometer connection — positive
- 28 Fuseboard F1, fuse B3, 10 Amp

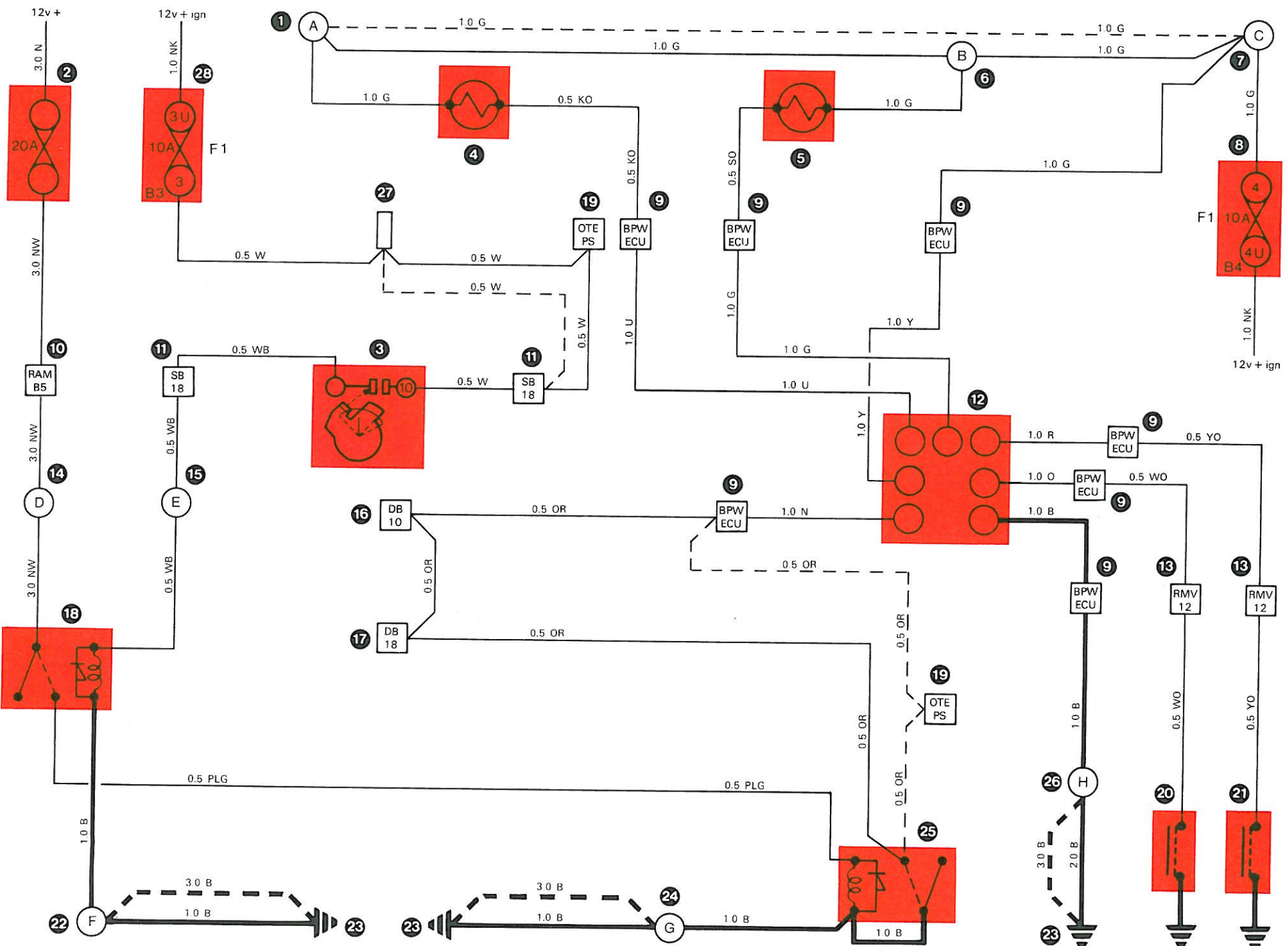

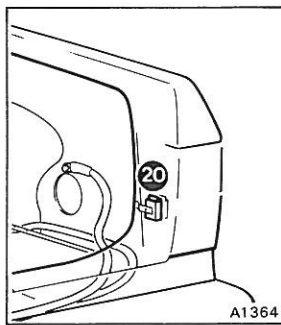
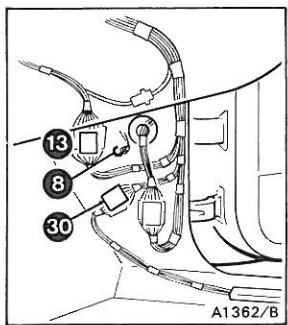
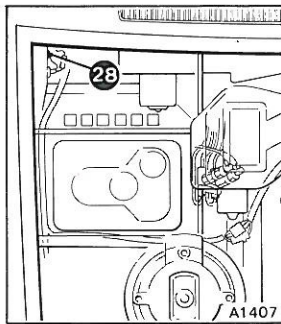
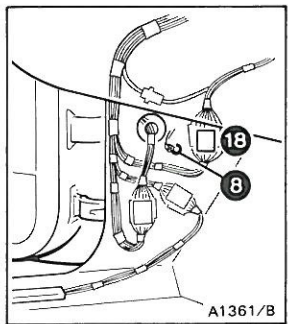
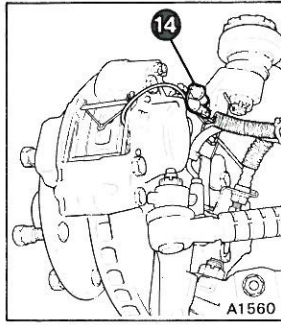
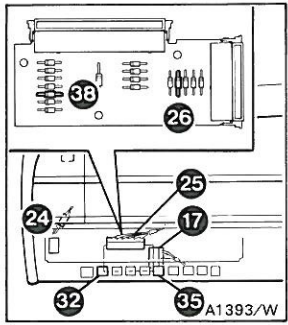
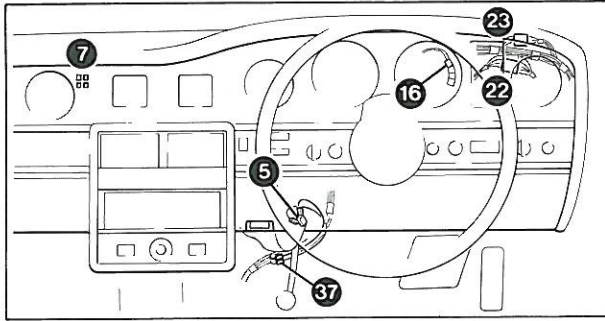

Key to 9-6

1 Splice A

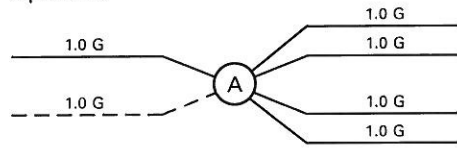

2 Splice B

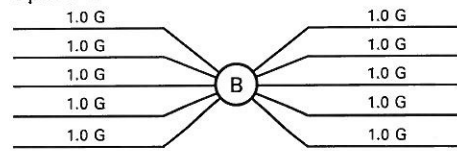

3 Splice C

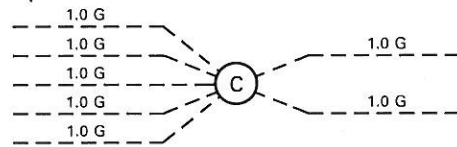

4 Parking brake warning lamp

5 Parking brake switch

6 Splice E

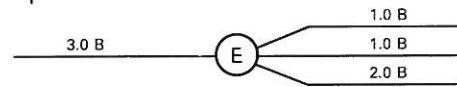

7 Instrument panel earth point

8 'A' post earth point

9 Fuseboard F1, fuse B4, 10 Amp

10 Fuseboard F1, fuse B3, 10 Amp

11 Splice D

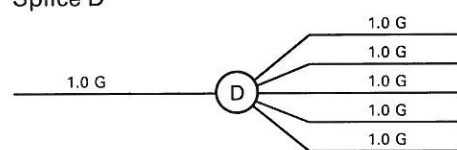

12 Brake pad wear warning lamp

13 Right-hand main to valance loom plug and socket 12-way

14 Right-hand brake pad wear sensor to valance loom connection

15 Right-hand front brake pad wear sensor

16 Speedometer connection - positive

17 Diode board plug 10-way

18 Left-hand main to valance loom plug and socket 12-way

19 Left-hand brake pad wear sensor to valance loom connection

20 Memory fuse, 20 Amp (located in luggage compartment)

21 Starter switch (switchbox)

22 Switchbox plug and socket 18-way

23 'Other than Europe' plug and socket

24 Brake pressure warning lamps electronic control unit plug and socket

25 Diode board plug 18-way

26 Diode (diode board)

27 Left-hand front brake pad wear sensor

28 Right-hand valance earth point

29 Left-hand valance earth point

30 Right-hand 'A' post main to body loom plug and socket 5-way

31 Splice G

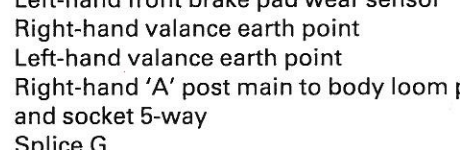

32 Cranking interlock relay

33 Splice F

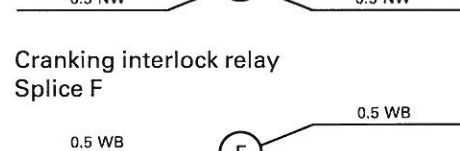

34 Splice H

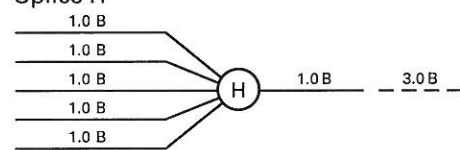

35 Warning lamps test relay

36 Splice J

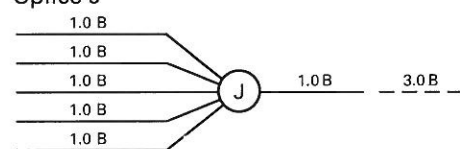

37 Parking brake link to main loom connection

38 Diode (diode board)

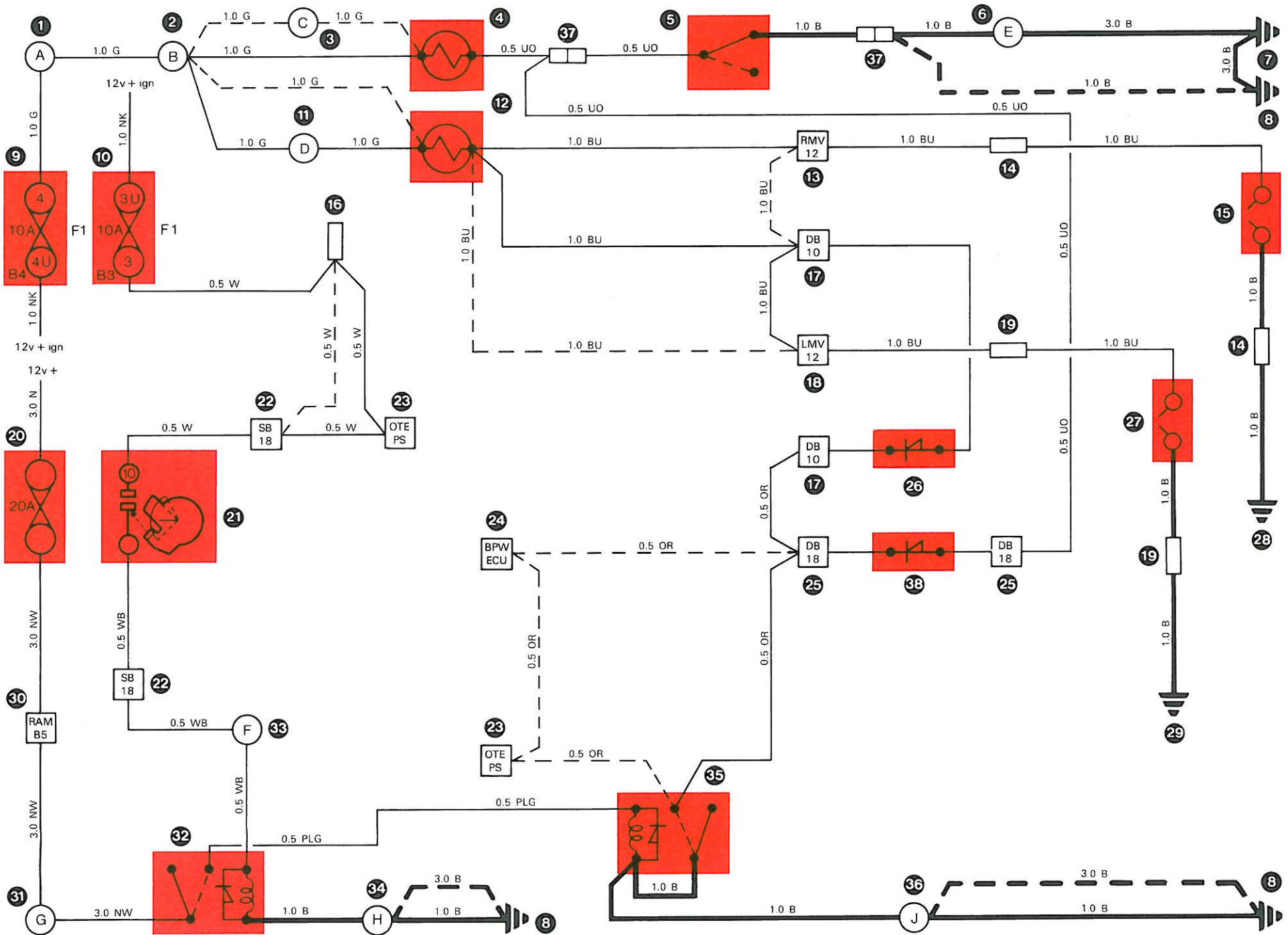

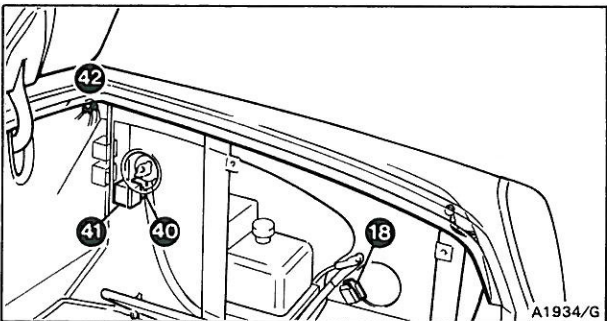
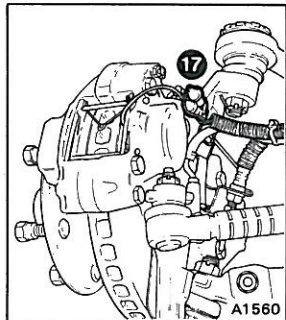
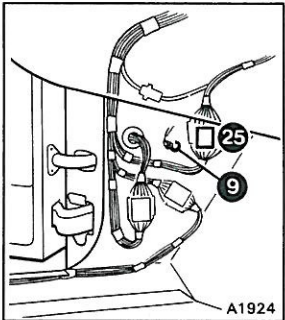
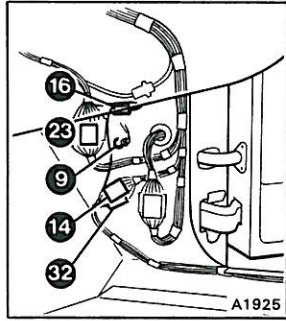
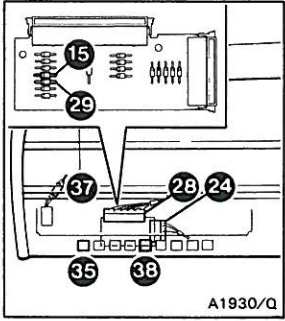
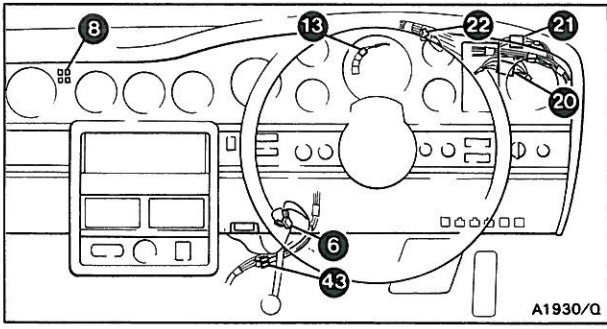

Key to 9-7

1 Splice A

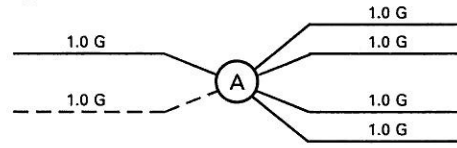

2 Splice B

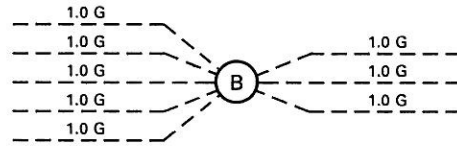

3 Splice C

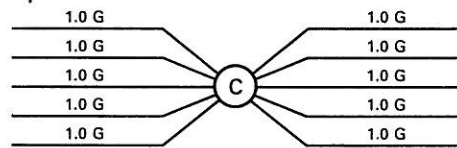

4 Parking brake warning lamp

5 Brake pad wear/stop lamp failure warning lamp

6 Parking brake switch

7 Splice D

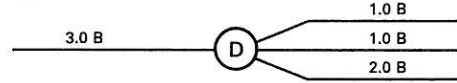

8 Instrument panel earth point

9 'A' post earth point

10 Splice H

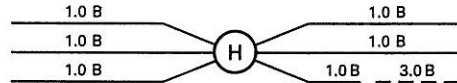

11 Fuseboard F1, fuse B4, 10 Amp

12 Fuseboard F1, fuse B3, 10 Amp

13 Speedometer connection - positive

14 Right-hand 'A' post main to body loom plug and socket 12-way

15 Diode (diode board)

16 Right-hand valance to body loom connection

17 Right-hand brake pad wear sensor to valance loom connection

18 Memory fuse, 20 Amp (located in luggage compartment)

19 Starter switch (switchbox)

20 Switchbox plug and socket 18-way

21 'Other than Europe' plug and socket

22 Brake pad wear warning lamp connection (taped back)

23 Right-hand main to valance loom plug and socket 12-way

24 Diode board plug 10-way

25 Left-hand main to valance loom plug and socket 12-way

26 Left-hand brake pad wear sensor to valance loom connection

27 Right-hand front brake pad wear sensor

28 Diode board plug 18-way

29 Diode (diode board)

30 Left-hand front brake pad wear sensor

31 Right-hand valance earth point

32 Right-hand 'A' post main to body loom plug and socket 5-way

33 Splice E

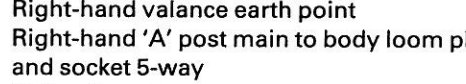

34 Splice F

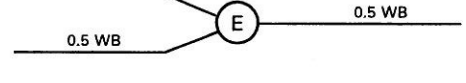

35 Cranking interlock relay

36 Splice G



37 Brake pressure warning lamps electronic control unit plug and socket

38 Warning lamps test relay

39 Left-hand valance earth point

40 Stop lamp failure amplifier plug 5-way

41 Stop lamp failure amplifier (for stop lamp failure circuit refer to Section 13)

42 Luggage compartment earth point - right-hand

43 Parking brake link to main loom connection

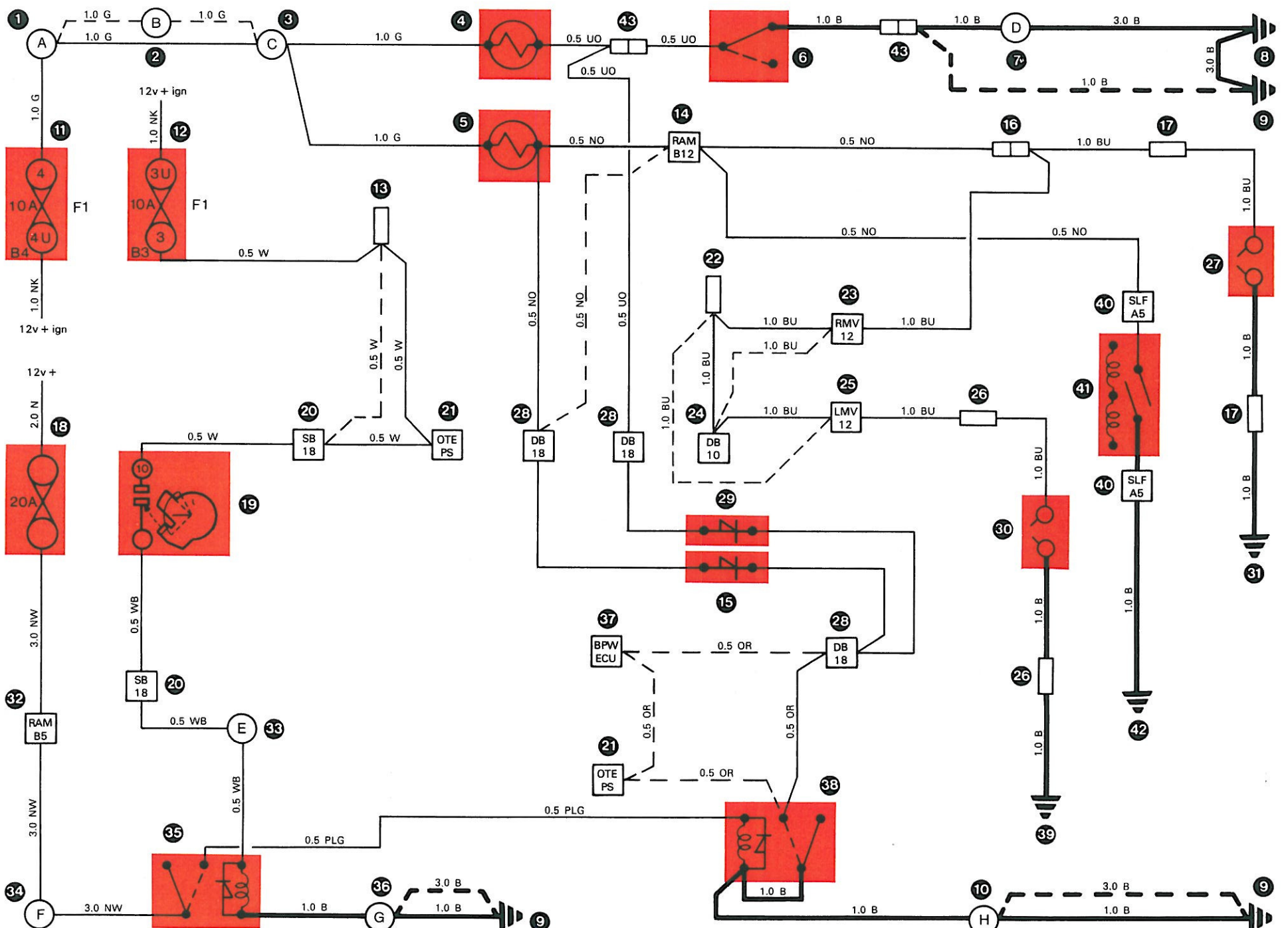

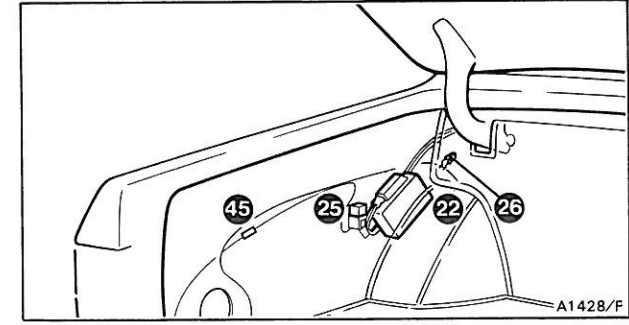
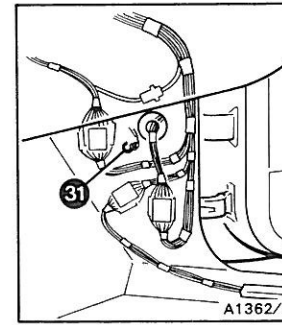
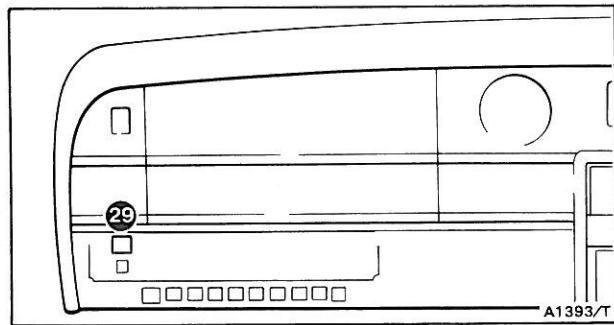
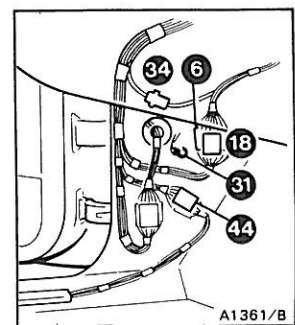
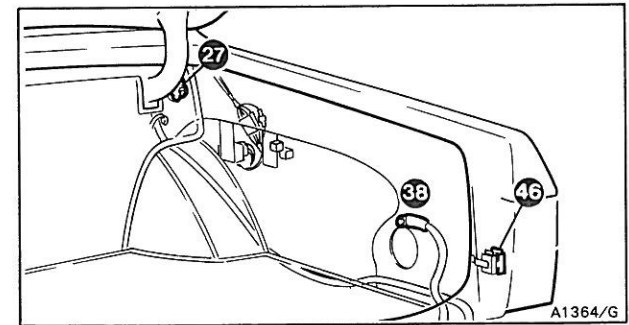
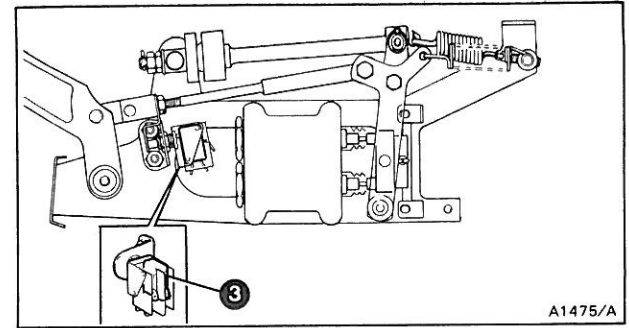
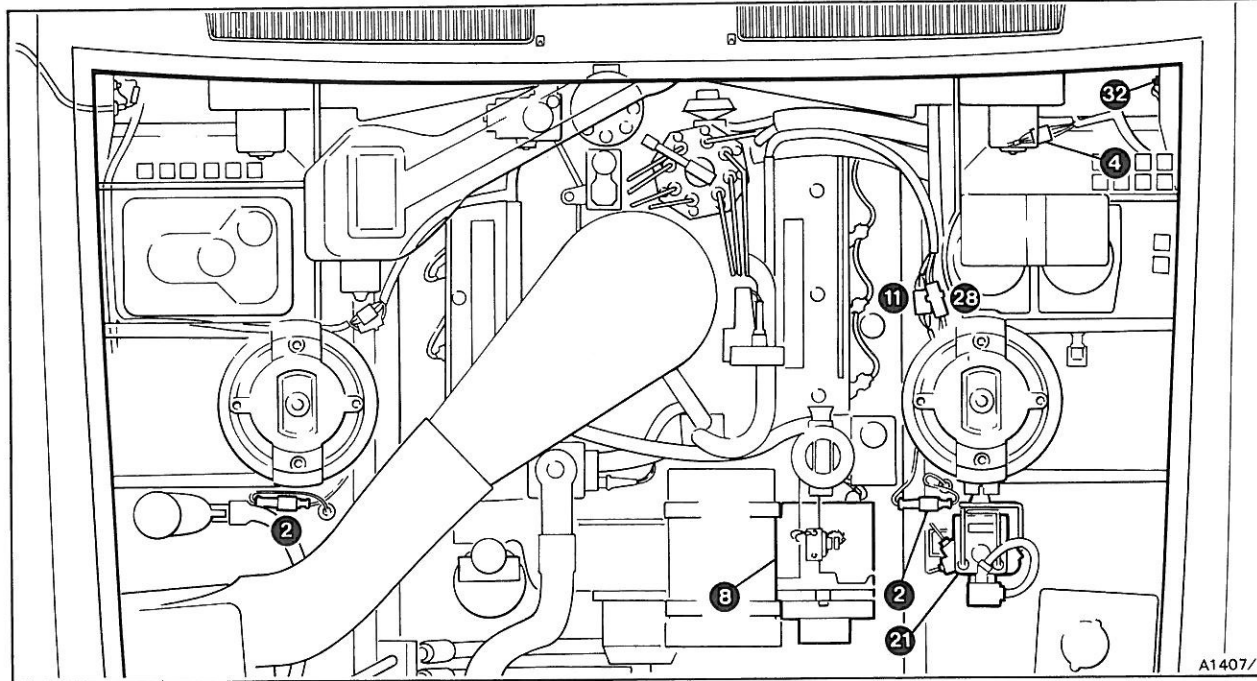
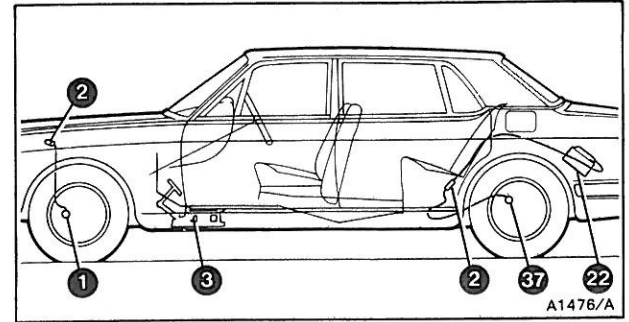
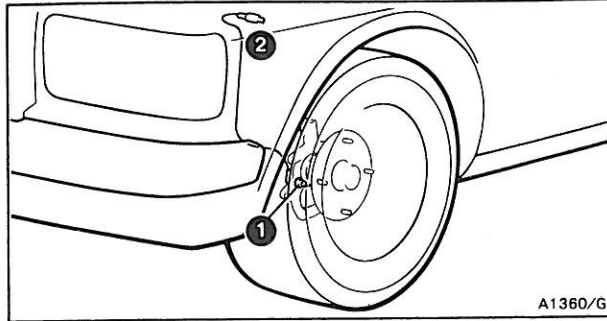
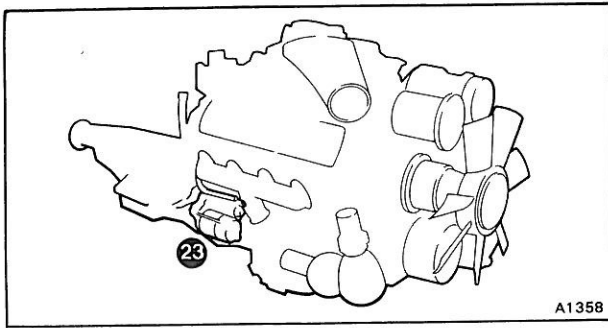

Key to 9-9

- 1 Left-hand front wheel sensor
- 2 Wheel speed sensor plug and socket
- 3 Stop lamps switch
- 4 Brake switch loom plug and socket
- 5 Splice A

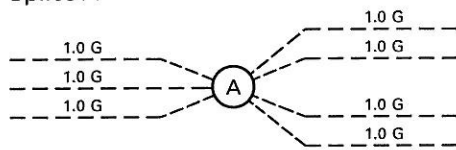

- 6 Left-hand main to valance loom plug and socket 7-way
- 7 Right-hand front wheel sensor
- 8 Alternator
- 9 Fusible link (at alternator)
- 10 Splice D

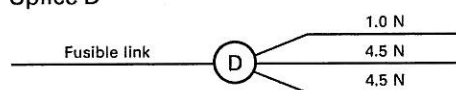

- 11 Left-hand valance to engine loom plug and socket 9-way
- 12 Splice E

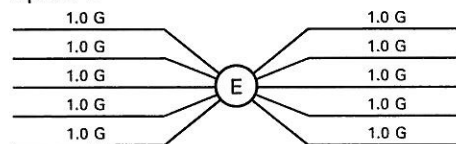

- 13 Splice F

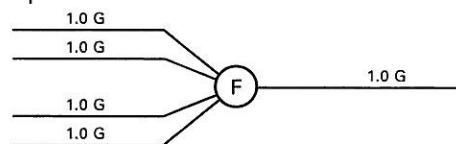

- 14 Splice B

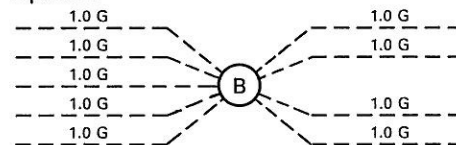

- 15 Splice C

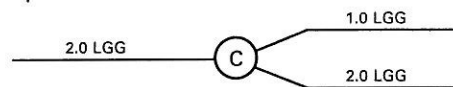

- 16 Fuseboard F1, fuse B4, 10 Amp
- 17 Fuseboard F2, fuse B3, 20 Amp
- 18 Left-hand main to valance loom plug and socket 12-way
- 19 Splice G

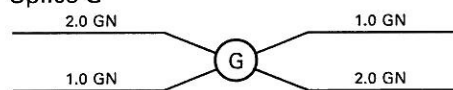

- 20 Anti-lock braking system warning lamp
- 21 Hydraulic modulator valves
- 22 Anti-lock braking system electronic control unit
- 23 Starter motor
- 24 Splice H

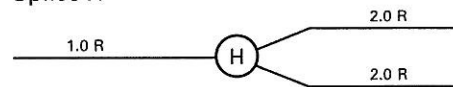

- 25 Modulator relay
- 26 Luggage compartment earth point - left-hand
- 27 Battery master switch (Cars other than those conforming to a West German specification)
- 28 Left-hand valance to engine loom 60 Amp connector
- 29 Anti-lock braking system relay and fuse
- 30 Splice J

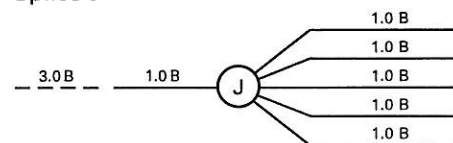

- 31 'A' post earth points
- 32 Splice P

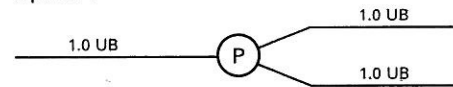

- 33 Battery
- 34 Left-hand main to valance loom 60 Amp connector

- 35 Splice K

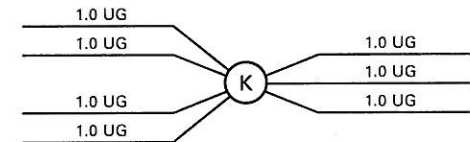

- 36 Fuseboard F1, fuse B2, 10 Amp
- 37 Left-hand rear wheel sensor
- 38 Battery earth point
- 39 Splice L

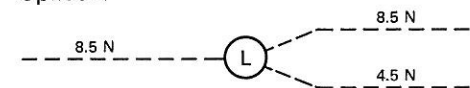

- 40 Splice M

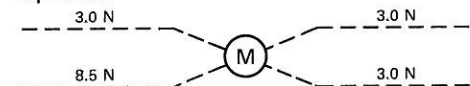

- 41 Splice N

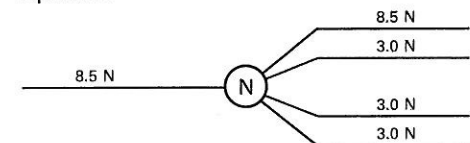

- 42 Splice O

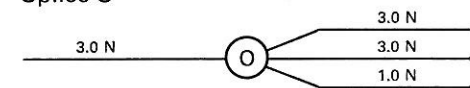

- 43 Right-hand rear wheel sensor
- 44 Anti-lock braking system plug and socket 5-way
- 45 Right-hand body loom to anti-lock braking loom connection
- 46 Anti-lock braking system fuse 20 Amp (located in luggage compartment)
- 47 Splice Q

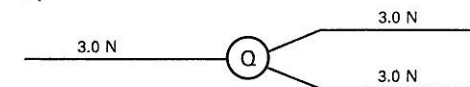

Two-door cars

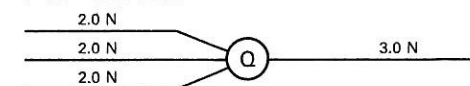

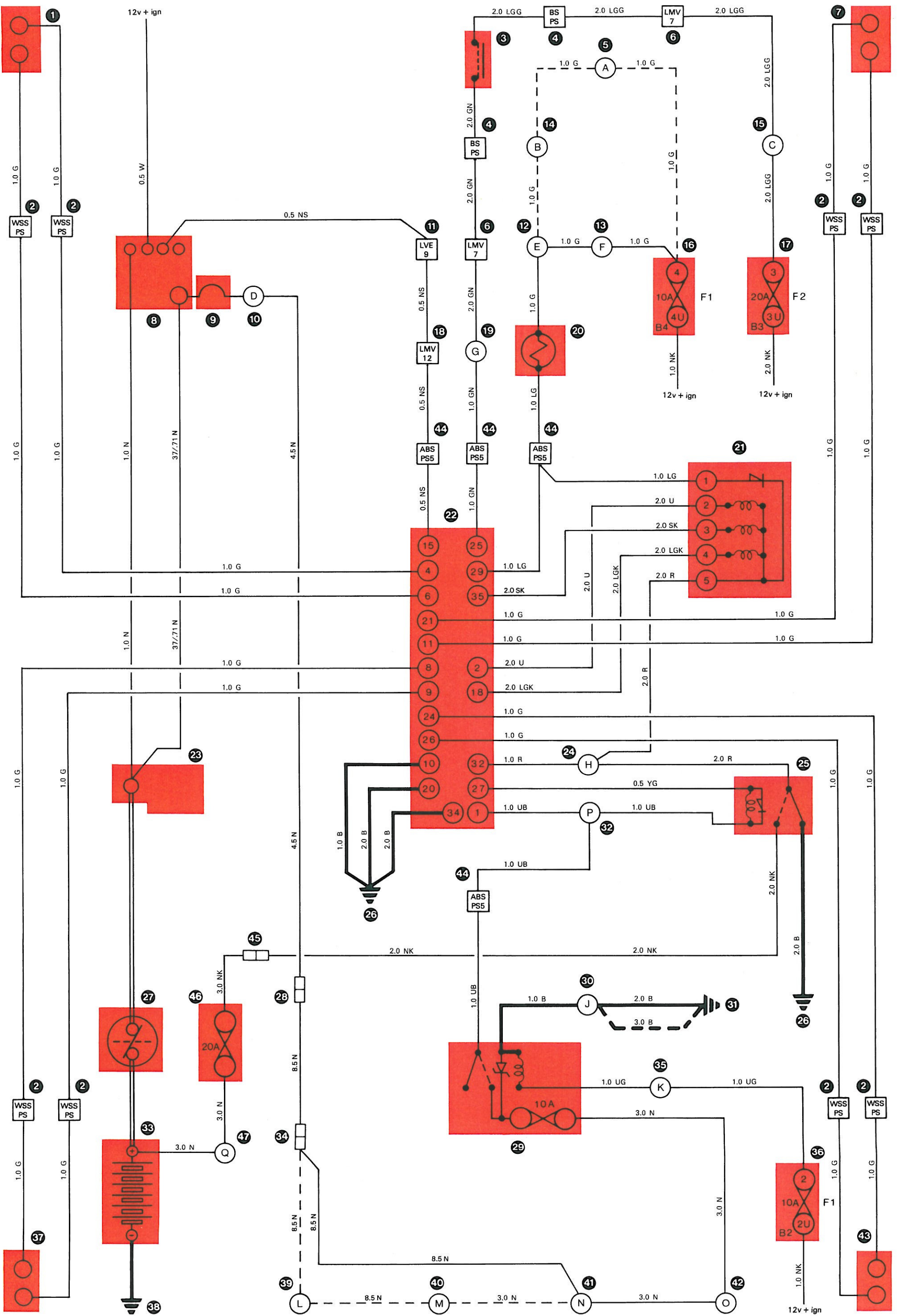

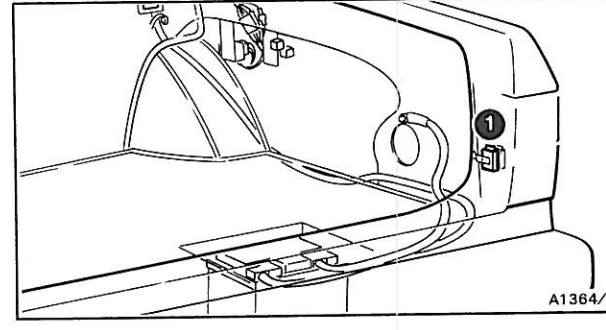
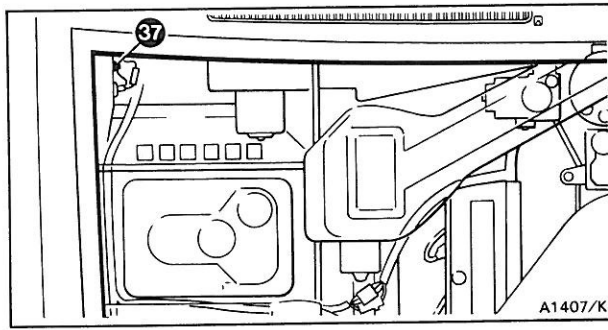
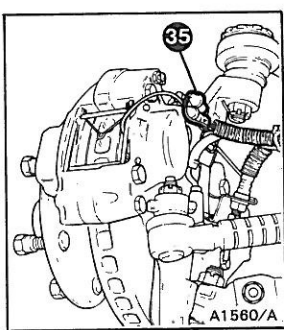
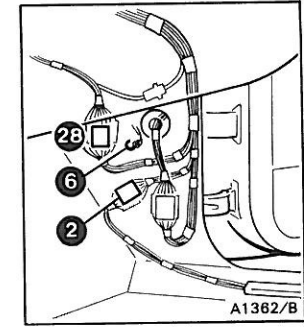
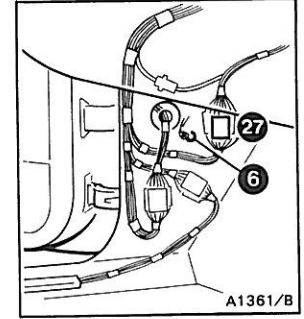
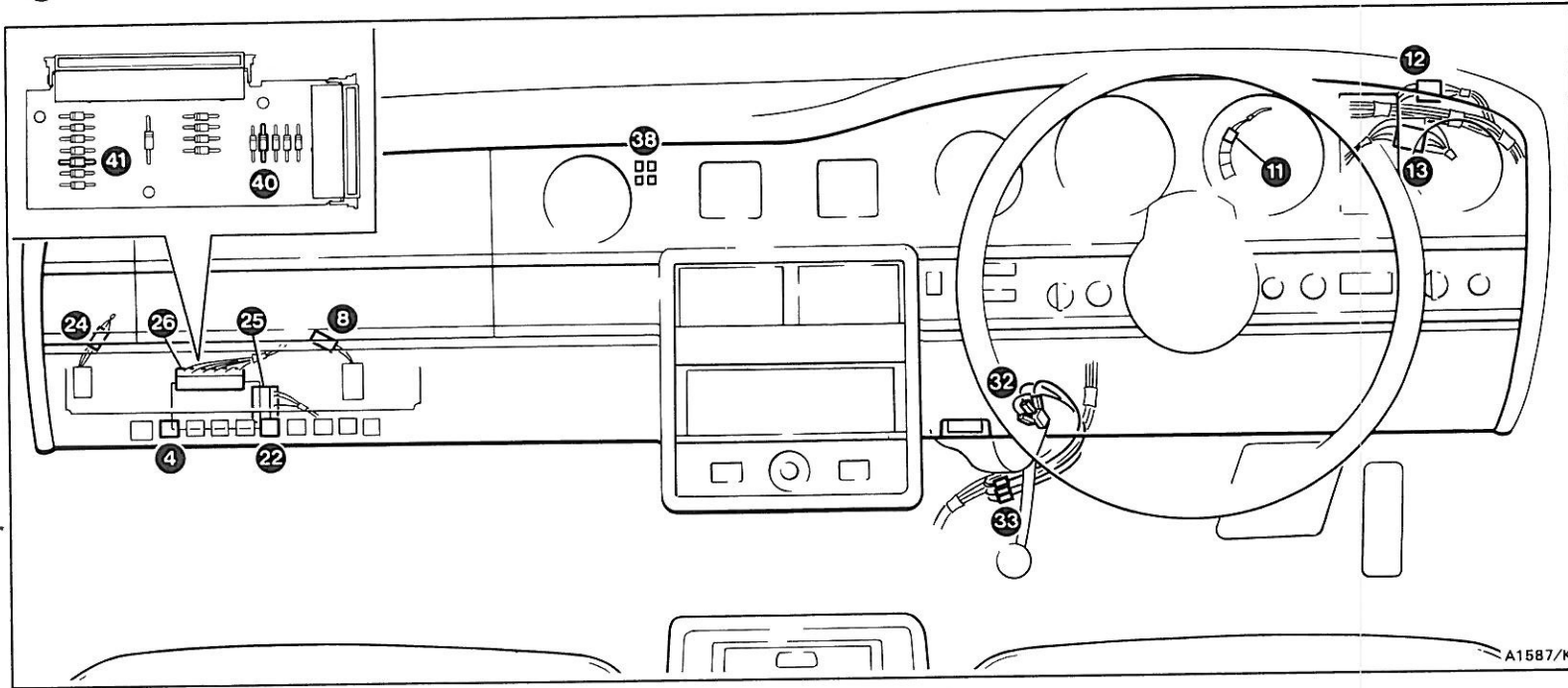

Key to 9-11

- 1 Memory fuse 20 Amp (located in luggage compartment)
- 2 Right-hand 'A' post main to body loom plug and socket 5-way
- 3 Splice A
- 4 Cranking interlock relay
- 5 Splice B

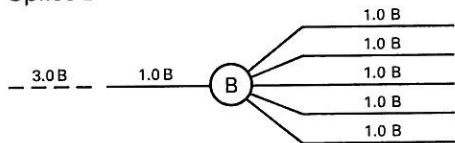
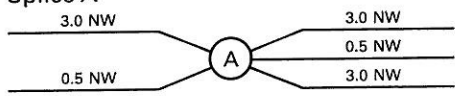

- 6 'A' post earth point
- 7 Fuseboard F1, fuse B3, 10 Amp
- 8 Engine running sensor plug and socket
- 9 Splice C

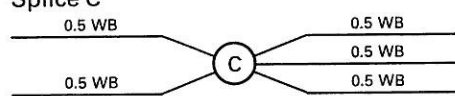

- 10 Splice D

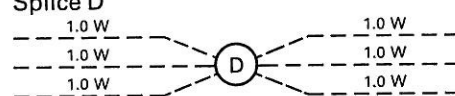

- 11 Speedometer connection – positive
- 12 'Other than Europe' plug and socket
- 13 Switchbox plug and socket 18-way
- 14 Starter switch (switchbox)
- 15 Fuseboard F1, fuse B4, 10 Amp
- 16 Splice E

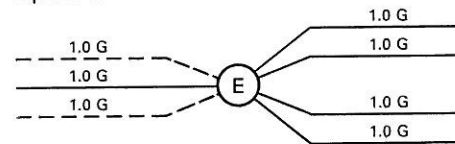

- 17 Splice F

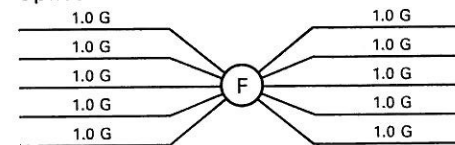

- 18 Splice G

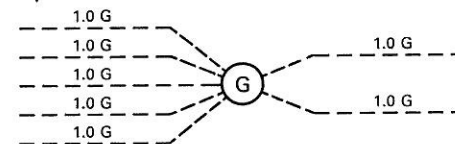

19 Splice H

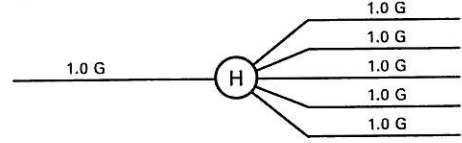

- 20 Parking brake warning lamp
Note On cars conforming to an Australian, Japanese, or North American specification the warning lamp also indicates brake pad wear when the parking brake is released and the ignition system is on
- 21 Brake pad wear warning lamp (Cars other than those conforming to an Australian, Japanese, or North American specification)
- 22 Warning lamps test relay
- 23 Splice J

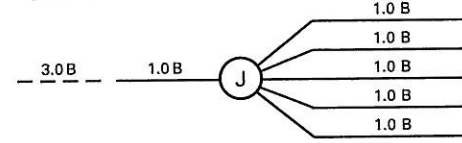

- 24 Brake pressure warning lamps electronic control unit plug and socket
- 25 Diode board plug 10-way
- 26 Diode board plug 18-way
- 27 Left-hand main to valance loom plug and socket 12-way
- 28 Right-hand main to valance loom plug and socket 12-way
- 29 Left-hand brake pad wear sensor to valance loom connection
- 30 Left-hand front brake pad wear sensor
- 31 Left-hand valance earth point
- 32 Parking brake switch
- 33 Parking brake link to main loom connection
- 34 Splice K

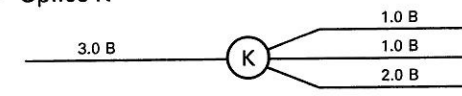

- 35 Right-hand brake pad wear sensor to valance loom connection
- 36 Right-hand front brake pad wear sensor
- 37 Right-hand valance earth point
- 38 Instrument panel earth point
- 39 Cable only connected on cars conforming to an Australian, Japanese, or North American specification
- 40 Diode (diode board)
- 41 Diode (diode board)

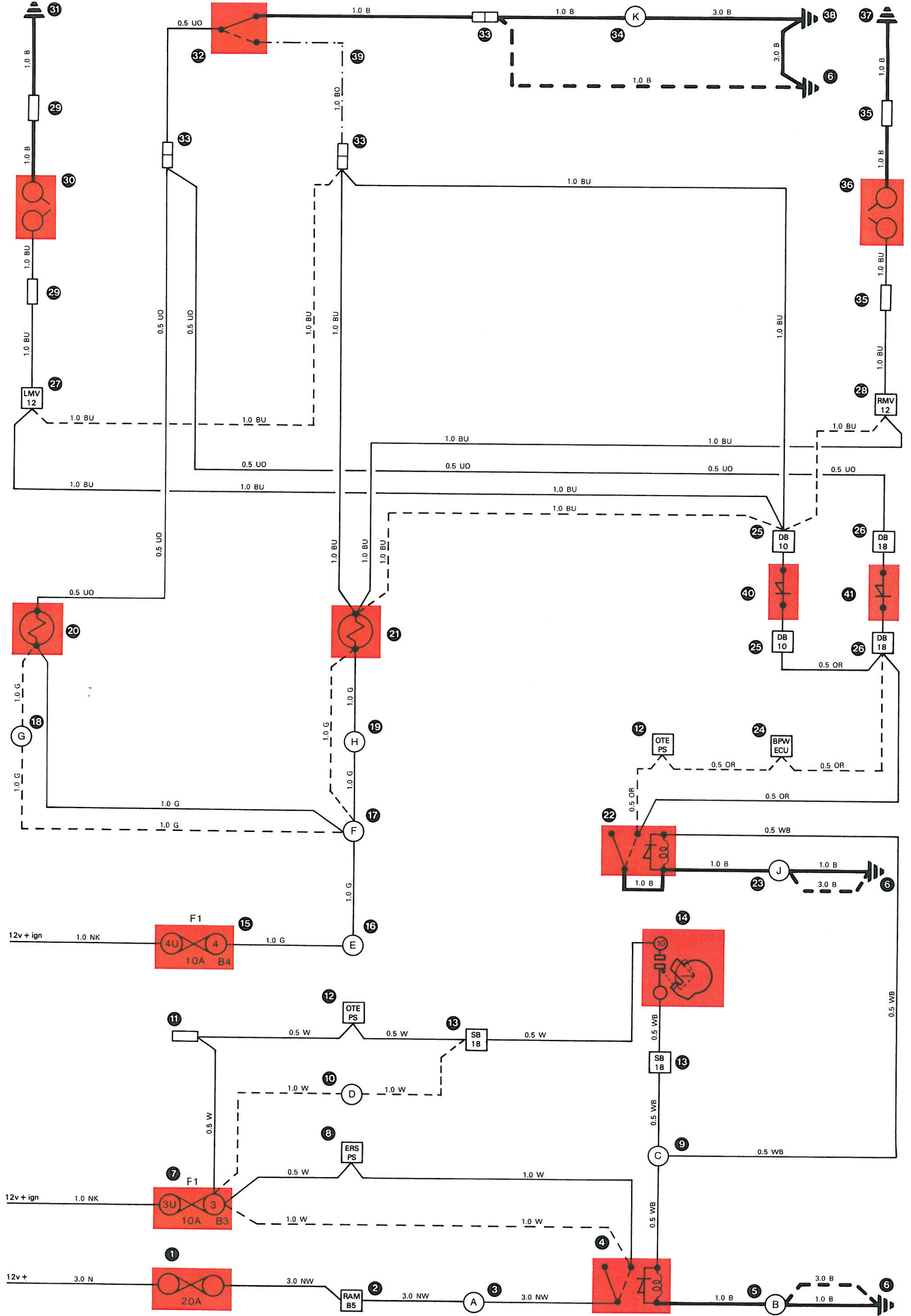

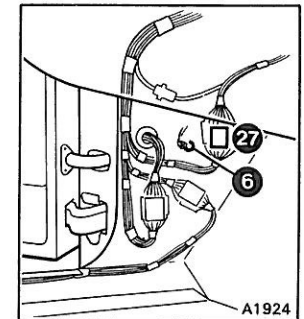
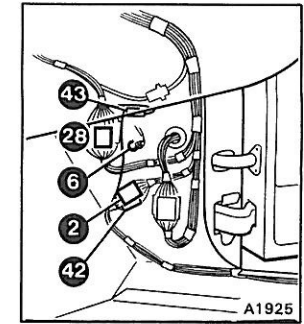
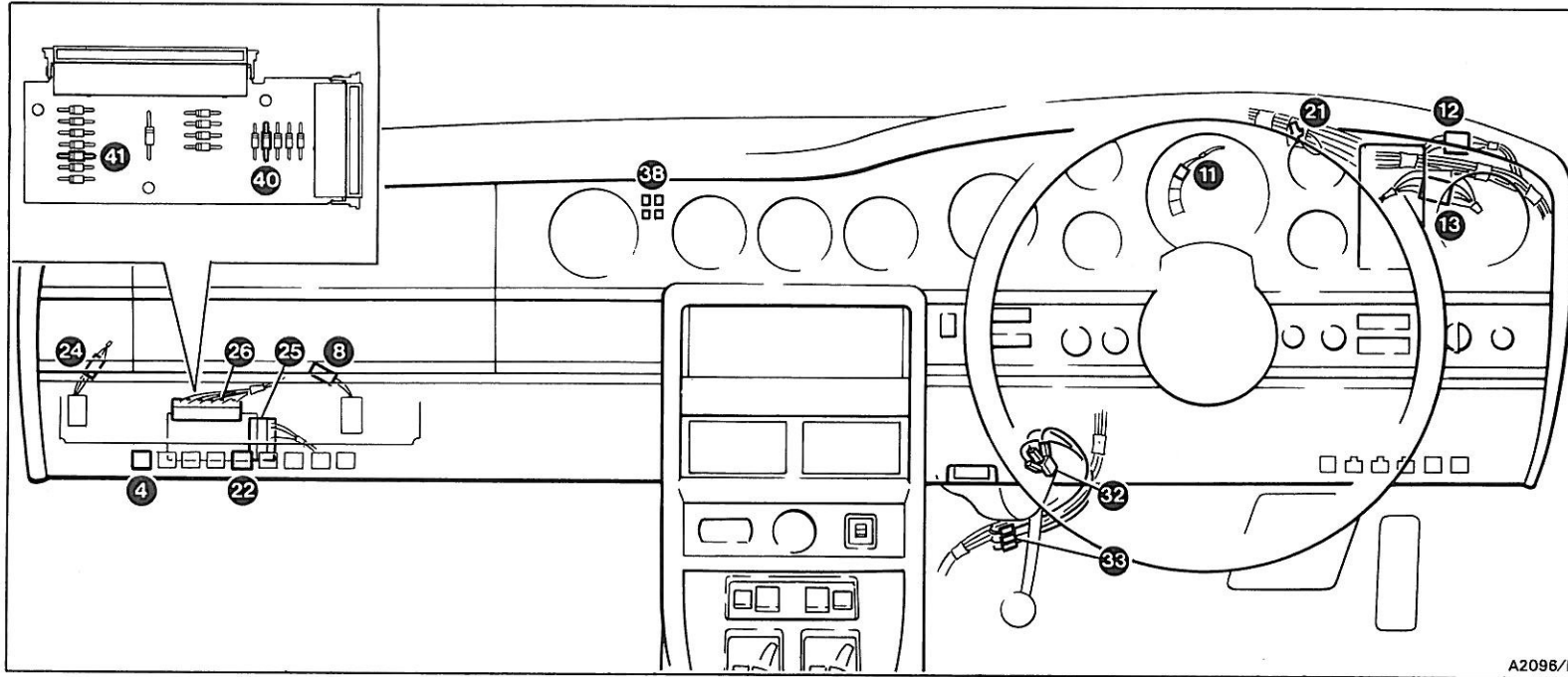

A2096/B

A1925

A1924

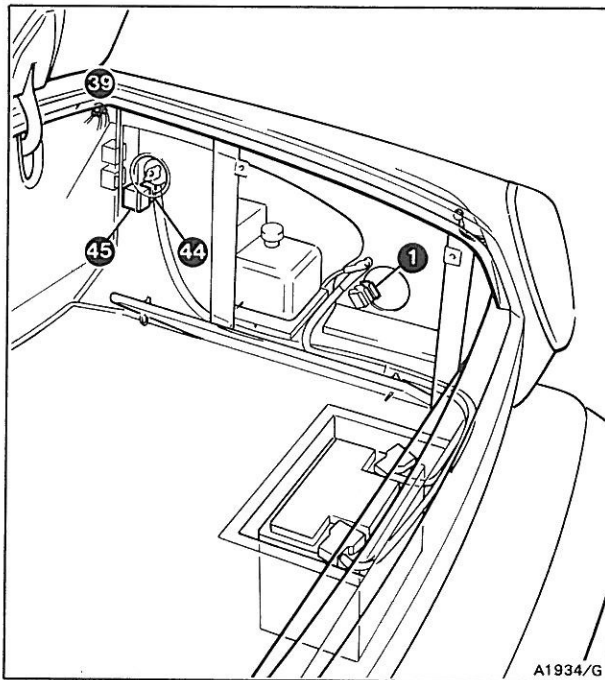

A1934/G

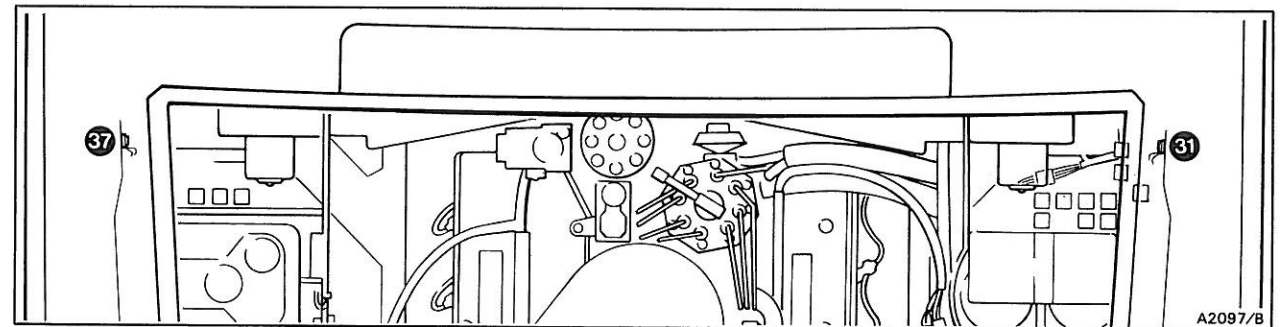

A2097/B

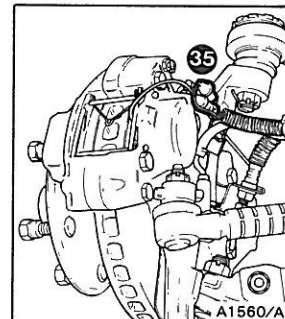

A1560/A

Key to 9-13

- 1 Memory fuse 20 Amp (located in luggage compartment)
- 2 Right-hand 'A' post main to body loom plug and socket 5-way
- 3 Splice A
- 4 Cranking interlock relay
- 5 Splice B
- 6 'A' post earth point
- 7 Fuseboard F1, fuse B3, 10 Amp
- 8 Engine running sensor plug and socket
- 9 Splice C
- 10 Splice D
- 11 Speedometer connection – positive
- 12 'Other than Europe' plug and socket
- 13 Switchbox plug and socket 18-way
- 14 Starter switch (switchbox)
- 15 Fuseboard F1, fuse B4, 10 Amp
- 16 Splice E

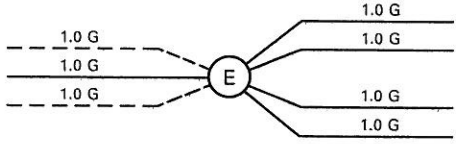
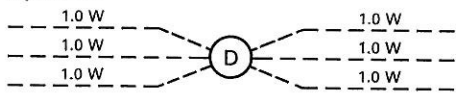
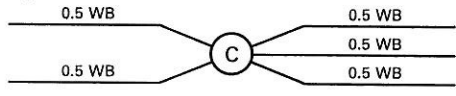
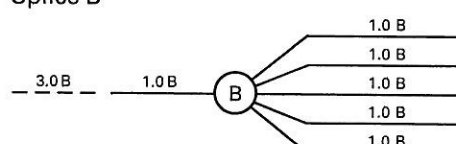
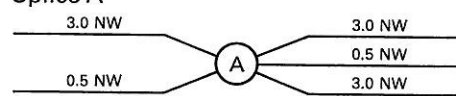

17 Splice F

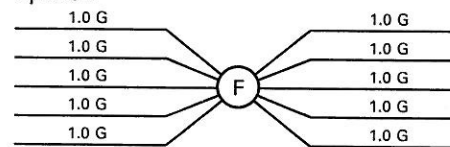

18 Splice G

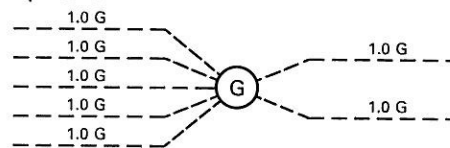

19 Splice H

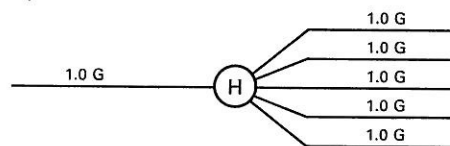

- 20 Brake pad wear, parking brake, and stop lamp failure warning lamp
- 21 Lampholder – bulb removed, lampholder taped into loom
- 22 Warning lamps test relay
- 23 Splice J

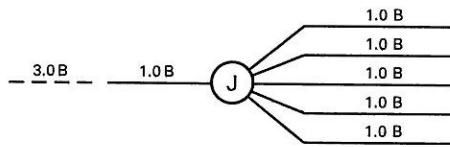

- 24 Brake pressure warning lamps electronic control unit plug and socket
- 25 Diode board plug 10-way
- 26 Diode board plug 18-way
- 27 Left-hand main to valance loom plug and socket 12-way
- 28 Right-hand main to valance loom plug and socket 12-way
- 29 Left-hand brake pad wear sensor to valance loom connection
- 30 Left-hand front brake pad wear sensor
- 31 Left-hand valance earth point
- 32 Parking brake switch
- 33 Parking brake link to main loom connection

34 Splice K

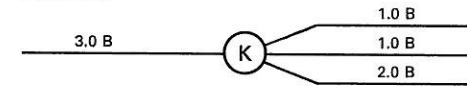

- 35 Right-hand brake pad wear sensor to valance loom connection
- 36 Right-hand front brake pad wear sensor
- 37 Right-hand valance earth point
- 38 Instrument panel earth point
- 39 Luggage compartment earth point – right-hand
- 40 Diode (diode board)
- 41 Diode (diode board)
- 42 Right-hand 'A' post main to body loom plug and socket 12-way
- 43 Right-hand valance to body loom connection
- 44 Stop lamp failure amplifier plug 5-way
- 45 Stop lamp failure amplifier

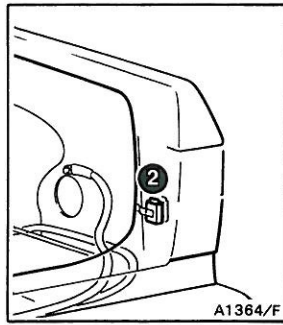
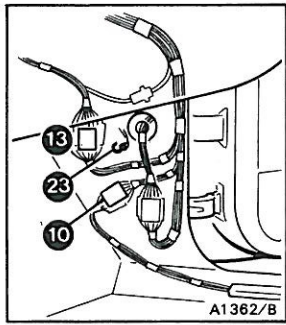
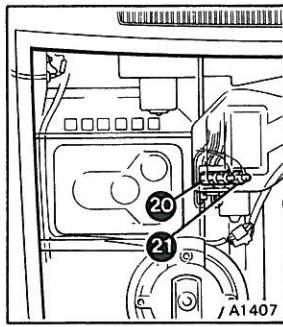
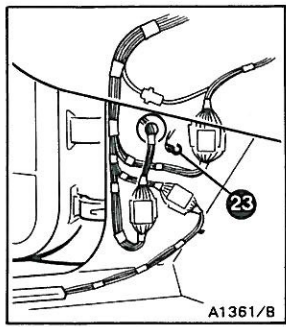
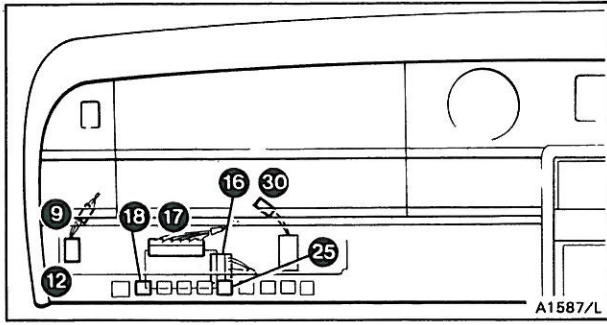
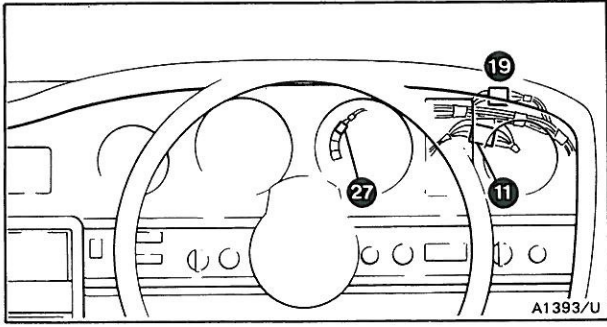

Key to 9-14

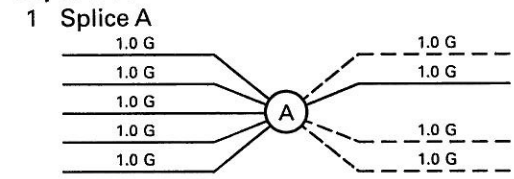

- 2 Memory fuse, 20 Amp (located in luggage compartment)
- 3 Starter switch (switchbox)
- 4 Brake pressure warning lamp 2
- 5 Brake pressure warning lamp 1
- 6 Splice B

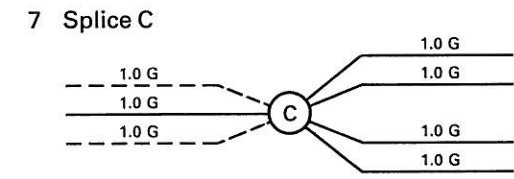
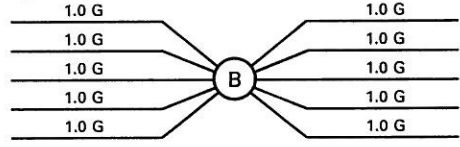

- 8 Fuseboard F1, fuse B4, 10 Amp
- 9 Brake pressure warning lamps electronic control unit plug and socket
- 10 Right-hand 'A' post main to body loom plug and socket 5-way
- 11 Switchbox plug and socket 18-way
- 12 Brake pressure warning lamps electronic control unit
- 13 Right-hand main to valance loom plug and socket 12-way
- 14 Splice D

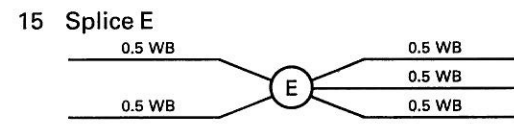
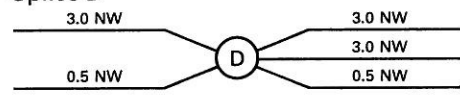

- 16 Diode board plug 10-way
- 17 Diode board plug 18-way
- 18 Cranking interlock relay
- 19 'Other than Europe' plug and socket
- 20 Brake pressure switch 2
- 21 Brake pressure switch 1
- 22 Splice F

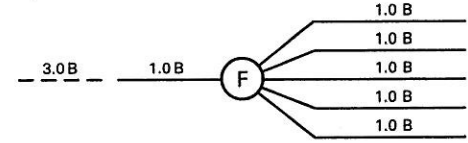

- 23 'A' post earth point
- 24 Splice G

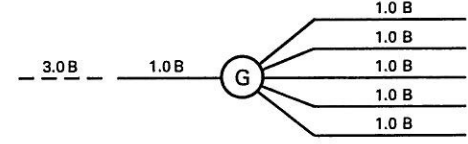

- 25 Warning lamps test relay
- 26 Splice H

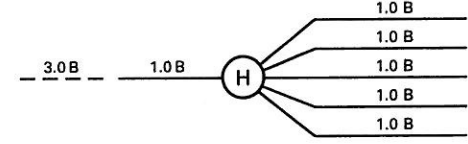

- 27 Speedometer connection - positive
- 28 Fuseboard F1, fuse B3, 10 Amp
- 29 Splice J

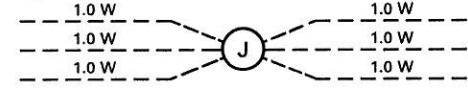

- 30 Engine running sensor plug and socket

