

**Bulletin**

MODEL : BENTLEY MARK VI

EXCESSIVE LEAKAGE OF OIL AT THE CENTRE STEERINGLEVER AND STUB AXLES(CENTRALISED CHASSIS LUBRICATION SYSTEM).FOR INFORMATION:

The information contained in this Bulletin will be of assistance to Retailers, in the event of complaint being received of excessive leakage of oil at the centre steering lever pivot assembly and the stub axles, leaving a pool of oil on the ground after the car has stood for several hours or overnight.

CAUSE:

When the pedal of the chassis oil pump is operated, a relatively large quantity of air is trapped in the three ball joints connected to the centre steering lever and compressed. During the next few hours, the trapped air expands, pushing the oil along until it escapes past the fulcrum pin bearings of the centre steering lever pivot assembly and the bearings of the stub axles.

REMEDY:

The cure lies in packing the four joints of the cross steering tubes and the ball joint at the front end of the side steering tube with a soft type of grease such as Duckham's HBB grease in order to displace the air.

It should be noted that the Chassis Oil Pump develops sufficient pressure to clear the oil feed pipe on the centre steering lever clear of grease.

TO REMOVE THE BALL JOINT AT THE FRONT END OF THE SIDE STEERING TUBE FROM THE CENTRE STEERING LEVER, PACK WITH GREASE AND REFIT.

- (i ) Remove the front right-hand undershield. Jack up front wheels and turn wheels to full right-hand lock.
- (ii ) Remove split pin and nut from ball pin.
- (iii) Place a substantial steady block in contact with the lever near the ball pin to be removed, in order to provide a solid re-action point, and then with the aid of a large steel drift and hammer, give the eye of the lever (adjacent to the ball pin) one or more sharp blows which will release the tapered shank of the pin from its location in the lever. NOTE: The above method applies to all the ball joints to be removed.
- (iv ) Collect the pressure spring and the sealing disc.
- (v ) Remove the cap nut of the joint (see Fig.1) and completely pack the joint with grease.

- 2 -

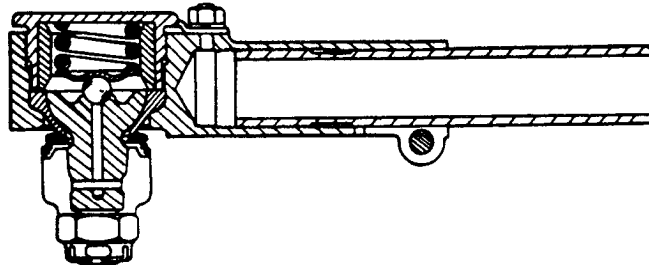

Fig. 1. Section through ball joint at front end of side steering tube.

- (vi) Before refitting the ball joint (ball pin) to the lever, clean the tapered shank of the pin and corresponding hole. With the sealing disc and pressure spring in position on the pin and the correct way round (See Fig. 1), refit the ball pin to the lever, fully tighten up the nut and secure with a new split pin of the correct size.

NOTE: Do not use a hammer when refitting the ball pin to the lever, but rely on tightening the nut to draw the mating parts together. Treat the four ball joints of the cross steering tubes in a similar manner. Fig. 2 shows a section through a ball joint (outer) of a cross steering tube. Finally inspect that no split pins, locking plates and spring washers have been omitted.

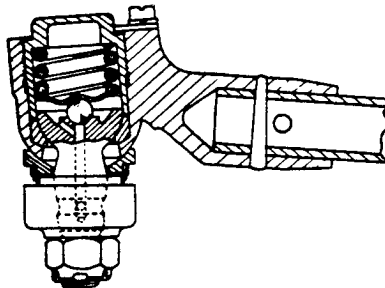
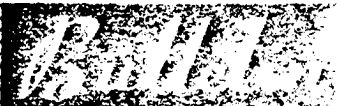

Fig. 2. Section through a ball joint (outer) of a cross steering tube.

OIL LEAKAGE FROM THE BEARINGS AS FITTED TO THE LOWER END OF EACH OF THE YOKES AND THE OUTER END OF EACH OF THE LOWER TRIANGLE LEVERS.

It is also possible that a leakage of oil may occur past the above mentioned bearings, therefore the opportunity should be taken to remove the Z 8000/102 Elbow meter Valve (2 off) situated at the front and outer end of each of the two lower triangle levers and replace them by two Z 8000/101 Elbow meter Valves, thus reducing the oil feed to the bearings. Later chassis are fitted with the Z 8000/101 type restrictors (Elbow meter Valves).



**CATEGORY 1 ACTION:**

**LOWER REAR SPRING PLATES,**

Retailers are advised that a new type of strengthened rear spring plate for the shock damper linkage attachment has been introduced on current models in production. This supersedes the earlier designs fitted and is now the only replacement available.

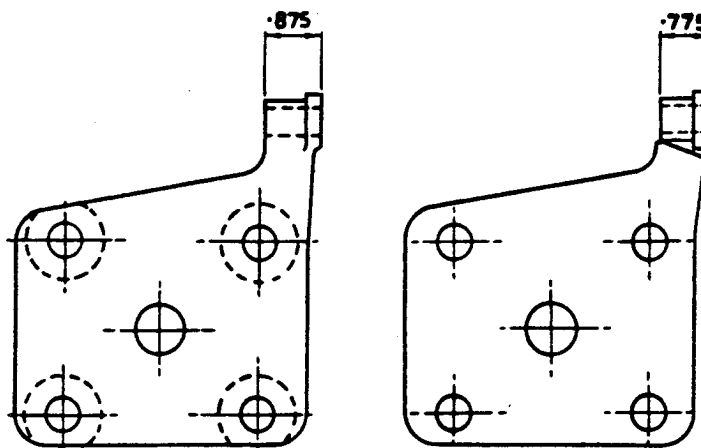

FIG. 1.

FIG. 2.

The new plate (Fig.1) is similar in general shape to the earlier designs, but no machining has been carried out on either face beyond the spot facing on the underside of the 'U' bolt holes. Owing to this, left-hand and right-hand plates are now required as follows:-

- RF-8537..... Rear Spring Plate, R.H.
- RF-8538..... Rear Spring Plate, L.H.

An intermediate type of modified spring plate, RF-8101 (Fig.2) was used for a short period prior to the introduction of the latest design, but this has proved unsatisfactory in service. In view of this, it has been decided to request Retailers to modify all cars in their areas fitted with this intermediate type plate on a Category 1 basis.

Although this calls for immediate retrospective action, it is realised that in many cases the geographical location of the car renders it impracticable in view of the simple nature of the work involved. In such cases, therefore, it is suggested that the action to be taken is left to the discretion of the Retailers, who may decide to forward the material and fitting instructions to the individual owner.

As a means of guidance to Retailers, the range of chassis fitted with the RF-8101 type rear spring plate is as follows:-

- B-444-FV onwards to end of FV series.
- All chassis in FU series.
- B-1-GT to B-65-GT incl. (excluding B-51 & 53-GT).

**Bulletin**

MODEL BENTLEY MARK IV

- 2 -

It should be noted, that due to the increased width of the boss on the new type plate (0.875" as against 0.775" on the earlier design) new anchorage pins for the lower shock damper linkage will also be required when these new plates are fitted. These pins are supplied separately, and should be assembled in their respective plates prior to these being fitted to the car.

Proceed as follows:- Insert the pin from the shouldered face of the boss, shorter end first, push fully home, and then fit and fully tighten up the lock nut. **Peen** over to lock.

The recommended procedure for the removal of the existing rear spring plates is as follows:-

- 1) Jack up the rear axle and support the chassis by placing suitable trestles either side of the frame just forward of the rear spring front shackles. Remove the road wheels.
- 2) Remove the split pin and castellated nut from the rear of the lower silentbloc bush of the shock damper linkage, and then tap the bush rearwards off the anchorage pin.
- 3) Remove the four 'U' bolt nuts below the spring and withdraw the lower spring plate.

Assembly of the new type spring plates is approximately the reverse of the above dismantling instructions. New split pins MUST be used.

Retailers are requested to inform this Depot of all chassis numbers on which this modification is incorporated.

Approximate time for fitting - 4 hours.

MATERIAL REQUIRED.

RF-8537	Lower Rear Spring Plate - R.H.	1 Off.
RF-8538	" " " " - L.H.	1 Off.
RF-8256	Pin - Lower Silent Block Bracket-Damper	2 Off.
K -4322	Lock nut.	2 Off.

# Bulletin

MODEL: BENTLEY MARK VI

## TYRE PRESSURES

### COACHBUILT BODIES.

The choice of correct tyre pressures is important to ensure the best steering characteristics and tyre life. The deciding factor is the weight of the vehicle which of course, varies with coachbuilt bodies.

The following are recommended pressures for average weights:-

Front - 23 lbs.sq.in. (1.65 Kg/CM<sup>2</sup>)  
 Rear - 30 lbs.sq.in. (2.15 Kg/CM<sup>2</sup>)

The weight on the front wheels is unlikely to vary sufficiently to warrant any alteration in the recommended front tyre pressures, but the rear axle weight on certain cars may necessitate an increase in the rear tyre pressures.

The following chart shows the recommended rear tyre pressures for a given unladen rear axle weight. (This weight is the kerbside weight, i.e. full tank but no passengers).

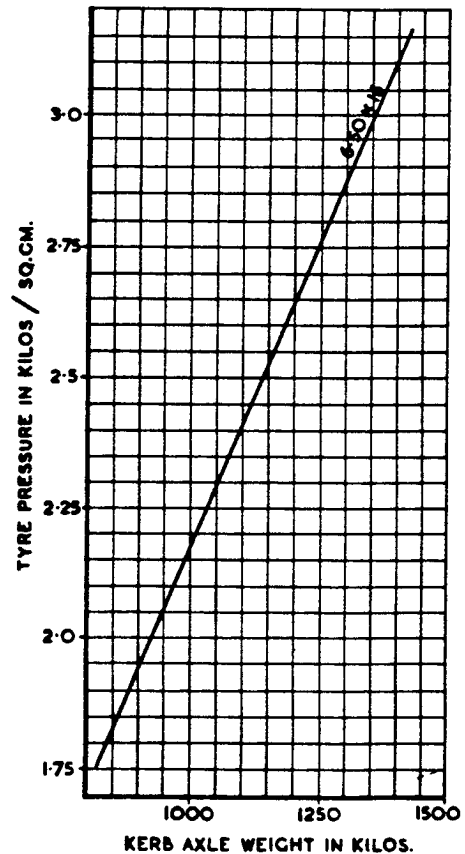
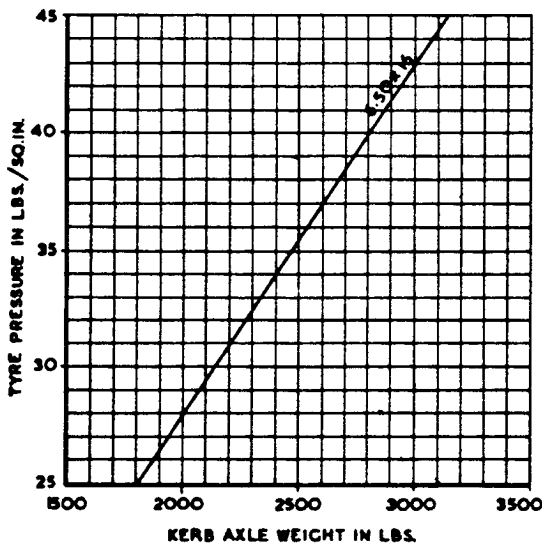

Certain cars which have a lot of overhang at the rear, but are not necessarily heavy, will steer better if the rear tyre pressures are increased a few pounds.

ALL COMMUNICATIONS SHOULD BE ADDRESSED TO  
 BENTLEY MOTORS (1921) LTD. PYM'S LANE, CREWE, ENGLAND.

**Bulletin**

MODEL: BENTLEY MARK VI

TYRE PRESSURESSTANDARD STEEL SALOON.

The altered characteristics of the new geometry steering which was introduced at Chassis No. B1-GT, resulted in a reduction in the slip angle of the front tyres, and therefore, there is less under-steer effect as compared with the old geometry. Some drivers may not like this reduction in under-steer, and the result may be a complaint of inferior directional stability. This effect is more noticeable on certain coachbuilt bodies which are tail heavy.

It will be found that an improvement in the handling characteristics of the car will be achieved by adopting the following tyre pressures:-

Front - 23 lbs. (1.65 Kg/CM<sup>2</sup>)  
Rear - 30 lbs. (2.15 Kg/CM<sup>2</sup>)

The above pressures will in future, apply to all standard steel saloons with the new geometry. The rear tyre pressure on coachbuilt cars may require increasing, depending on the weight of the body.

Separate instructions are being issued regarding recommended pressures for different weights.

For cars with the old steering geometry, i.e. prior to B1-GT, it is undesirable to reduce the front tyre pressures and our recommendations therefore, stand as follows:-

Front - 25 lbs. (1.8 Kg/CM<sup>2</sup>)  
Rear - 30 lbs. (2.15 Kg/CM<sup>2</sup>)

# Bulletin

MODEL: BENTLEY MARK VI

FOR CATEGORY 2 ACTION:MODIFICATIONSIDE STEERING TUBE - FRONT END SOCKET.

Commencing at Chassis No.B-215-PU steel balls (12 Fig.2) were incorporated in place of the previous bronze seat (2 Fig.3) in the front end socket of the side steering tube to reduce steering friction.

Owing to the steel balls grooving and causing hard steering, these have been discarded and reversion has been made to the original bronze seat as from Chassis No.B-390-TN and onwards on right-hand and left-hand drive cars.

This modification is therefore introduced to modify Chassis Nos.B-215-PU to B-388-TN (inclusive) to revert to the previous arrangement.

The following Bentley Continental cars also require this modification:- Chassis Nos.BC-11-A, BC-12-A, and BC-15-A up to BC-29-C inclusive.

1. PARTS REQUIRED (RE-INTRODUCED):

<u>Part No.</u>	<u>Title.</u>	<u>No.Off.</u>
FW-403	Pressure spring-sealing disc-front socket.	1
FW-996	Bronze seat-front socket.	1
RF-3561	Sleeve-front socket.	1
RF-3563	Sealing disc-mud excluder-front socket.	1
FW-1000	Ball end pin-front socket.	1
K-4608/Z	Split pins-ball end pins-inner end of cross steering tubes.	2
K-4614/Z	Split pins-ball end pins-side steering tube.	2
K-4616/Z	Split pin-rear end cap-side steering tube.	1

2. TO REMOVE THE SIDE STEERING TUBE:

In order to remove the ball end pin (10 Fig.2) connecting the front end of the side steering tube to the centre steering lever, it will be necessary to remove the centre steering lever unit from the frame complete with levers and the side steering tube. Proceed as follows:-

- (i) Remove the front undershield, (on R.H. side for R.H. drive cars and on L.H. side for L.H. drive cars.)
- (ii) Disconnect the inner ends of the two cross steering tubes from the cross steering tube centre link as below:-
  - a) Remove the castle nut securing each ball end pin to the outer ends of the link.
  - b) Place a substantial steady block in contact with the centre link near the ball pin to be removed, in order to provide a solid reaction point, and then with the aid of a large steel drift and hammer, give the eye of the centre link (adjacent to the ball pin) one or more sharp blows which will release the tapered shank of the ball pin from its location in the link. Collect the mud excluders and their pressure springs.

ALL COMMUNICATIONS SHOULD BE ADDRESSED TO

BENTLEY MOTORS (1931) LTD., PYM'S LANE, CREWE, ENGLAND

# Bulletin

MODEL: BENTLEY MARK VI

- 2 -

(iii) Disconnect the rear end of the side steering tube from the pendulum lever (drop arm) of the steering box as follows:-

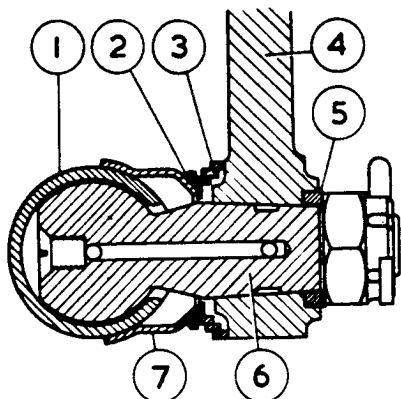

FIG.1. SECTION - BALL JOINT-SIDE STEERING TUBE REAR END.

a) Remove the castle nut and the locating washer, 5 Fig.1 from the ball end pin(6), then give the bottom of the pendulum lever (4) a sharp tap upwards, i.e. at right-angles to the axis of the ball pin. This should release the pin. A large steady block should be held against the upper end of the lever to absorb the shock, and a drift used on the lower end to prevent damage to adjacent parts.

b) If the ball pin when released cannot be removed from the pendulum lever owing to lack of clearance between the side steering tube and the frame, it will be necessary to unscrew the internal nut from the rear end of the side steering tube and remove the rear guide, spring and ball pad after which the ball pin can be pushed into the side steering tube away

from the lever. When removing the side steering tube (later), take care not to lose the inner ball pad, spring, or the rear guide.

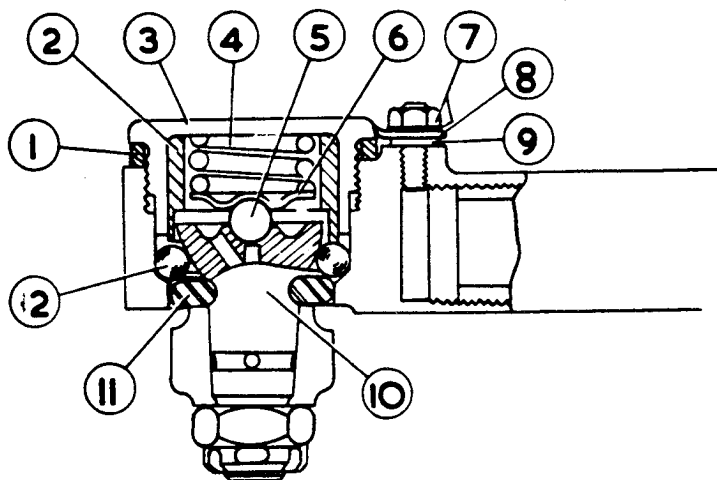

FIG.2. SECTION-SOCKET-SIDE STEERING TUBE FRONT END (PRIOR TO MODIFICATION.)

c) Collect the pressure spring 3, Fig.1, the sealing disc, (2) and mud excluder (7).

(iv) Remove the oil feed pipe (part of chassis lubrication system) and connections from the upper end of the centre steering lever unit.

(v) Remove the two  $\frac{3}{8}$ " B.S.F.nuts situated on the underside of the centre (jacking) plate at the rear end of the plate. Also remove the two  $\frac{3}{8}$ " B.S.F.nuts

from the upper end of the unit. These two nuts face towards the rear of the car. Remove the unit from the frame complete with the side steering tube.

**NOTE IMPORTANT:** It may be found that packing washers are fitted between the unit and the frame both at the lower and upper end, in which case, care must be taken when refitting the unit to the frame that the packing washers are placed in their ORIGINAL position/s.

(vi) Disconnect the front end of the side steering tube from the centre steering lever.

ALL COMMUNICATIONS SHOULD BE ADDRESSED TO

BENTLEY MOTORS (1931) LTD., PYM'S LANE, CREWE, ENGLAND

- 3 -

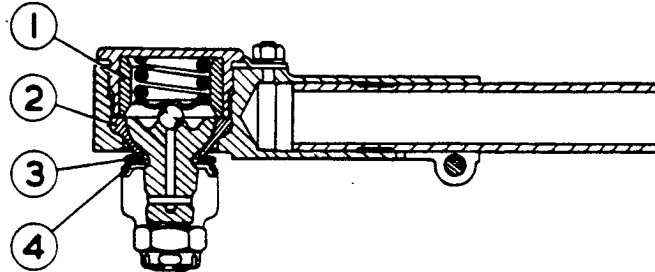

FIG.3. SECTION-SOCKET-SIDE STEERING TUBE FRONT END  
(AFTER MODIFICATION.)

1. Sleeve - front socket. (RF-3561)
2. Bronze seat - front socket. (FW-996)
3. Sealing disc - mud excluder - front socket. (RF-3563)
4. Pressure spring - sealing disc - front socket. (FW-403)

3. TO MODIFY THE FRONT END SOCKET (JOINT) OF THE SIDE STEERING TUBE:

- (i) Remove the rubber seal (11 Fig.2) from the groove in the ball pin.
- (ii) Remove the nut and spring washer, (7), the locking plate (8), the plain washer (9), and with a 'C' spanner, remove the cap nut (3).
- (iii) Remove the joint ring (1) from the cap nut, the sleeve (2), the spring (4), the spring pad (6), the ball (5), the ball pin (10), and finally the steel balls (12). Items 1, 2, 9, 11 and 12, should be discarded. The sleeve (2) is replaced by the sleeve RF-3561. Clean the remaining dismantled parts.
- (iv) Re-assemble the ball joint, using the new parts as illustrated in Fig.3, and refit to the centre steering lever.

**NOTE:** When it is found that the ball end pin (10 Fig.2) of the front socket has been grooved or pitted by the steel balls, a new pin FW-1000 (included in the list of parts on Page 1) should be fitted.

Before refitting a ball joint (ball pin) to a lever, clean the tapered shank of the ball pin and corresponding hole. Do NOT use a hammer, but rely on tightening the castle nut to draw the mating parts together.

- (v) Refit the centre steering lever unit to the frame by reversing the operations for removal and re-connect the side steering tube to the pendulum lever.

**NOTE:** When re-connecting the side steering tube to the pendulum lever, it is important that the mud excluder (7 Fig.1) is placed the correct way round, i.e. with the longest plain portion pointing

(cont'd)

**Bulletin**

MODEL: BENTLEY MARK VI

- 4 -

towards the rear end of the tube. After placing the ball pin in the pendulum lever, make sure that the flats and lugs of the locating washer (5 Fig.1) correctly engage with the corresponding flats and slots on the ball pin and in the lever.

If it was found necessary to remove the slotted end-nut, rear ball pad and the spring and guide assembly from the rear end of the side steering tube then prior to placing the ball pin in the pendulum lever measure the length of the coil spring and if it has a free length of 0.875" (22.2 m/m) the adjustment of the rear end of the side steering tube is as follows:-

- a) With the ball pin and its associated parts in position in the rear-end of the side steering tube screw in the end-nut until the ball pin can just be moved by hand.
- b) Gradually unscrew the nut until the load on the ball pin is as light as possible without any slackness between it and the adjacent ball pads. If it is desirable to make the steering more positive the load on the ball pin may be increased with discretion.

If the spring has a free length of 1.225" (31.1 m/m) then adjust as below:-

Screw in the slotted end-nut, until the ball pads, spring and guide assemblies are choc-a-bloc. Slacken the end-nut back 0.100" (2.5 m/m) in order to restore the original working clearance of 0.050" (1.27 m/m) between the end of each stem of the ball pads, and the inner end of the tube and the inner face of the end-nut. In all cases the end-nut must be secured by a new split pin. Part No. K.4616/Z.

- (vi) Finally inspect that no split pins have been omitted. Will Retailers please notify the London Service Station of the chassis number of the car whenever they carry out this modification.

Time allowed for job is 6 hours.