

MODEL BENTLEY MARK VI

STONE GUARDS ON REAR WINGS AND SILL.

Moulded rubber stone guards on the front of the rear wings and the rear end of the sills are now a standard fitment. Some cars may not have been fitted with them, in which case they may be fitted on request. In such cases they may be obtained in sets from Hythe Road Service Station together with the requisite quantity of the materials necessary for affixing them.

To fit the stone guards, first, accurately align the front edge, and with the guard pressed tightly to the wing, mark out the outline. Remove the guard, and thoroughly clean and degrease the paint using a reliable agent, trichlorethylene being the most satisfactory. Brush on a thin even coat of Bostik Company's Primer 81-15 and allow this to dry for  $1\frac{1}{2}$  hours, taking precautions to keep it free from dust. Rice paper if available, will not permanently adhere and is an excellent cover.

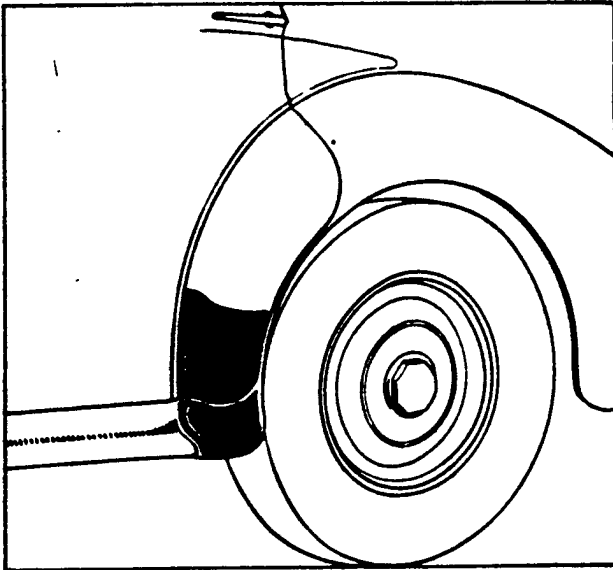

STONE GUARD IN POSITION.

cement can be wiped clear of any paint which has not been affected by the primer, even after it has set.

The Part Numbers of the Guards are:-

Rear Wing, L.H.	RB. 3525
Rear Wing, R.H.	RB. 3524
Sill, L.H.	RB. 3827
Sill, R.H.	RB. 3826

Next roughen the inner surface of the rubber using No.2 emery cloth or similar means. Mix thoroughly together the quantities of Bostik Company's Cement Boscroprene 2400/1 and 2400/2 as supplied, and applying one coat evenly to both the rubber and the metal, allow to dry for 45 minutes. Note that when mixed, the cement will last only 24 hours, therefore mix only the necessary amount.

When applying the rubber to the metal after the requisite drying period, tack the front top corner in position, gently align the front edge, and when sure of the position, firmly press it home. Then work from front to rear with a roller keeping the top edge in line with the marking out, and squeezing out any wrinkles and air bubbles. The

**Bulletin**

MODEL BENTLEY MARK VI

STONE GUARDS ON REAR WINGS AND SILLAMENDMENT.

As the Bostik Company's preparations mentioned in Service Bulletin BB-3 are suited only for factory use where it is possible to handle a number of cars simultaneously, an alternative procedure is desirable when dealing with odd cars.

In these instances Bostik C adhesive No.252 is recommended. This can be supplied in 8-oz. tubes. sufficient for fixing one set of Stone Guards.

No primer is needed, but the wing and sill surfaces must be thoroughly cleaned and degreased, after which a thin coat of No.252 adhesive is applied to both metal and rubber, the latter being previously roughened.

The coated surfaces must be allowed to dry for 45 minutes before fixing.

# Bulletin

MODEL : BENTLEY MARK VI

## FRONT SEATS - BENTLEY STANDARD SALOON.

There have been one or two instances where the front seats have split at the rear corners where the top leather is stitched to the side panel. The reason for this is that the side leather is anchored to the back of the seat on the outside of the framework and cannot flex inwards sufficiently to follow up deflection of the top leather.

An alteration has therefore been made as shown in the drawing herewith. It will be seen that the side wall is now detached from the back and is passed inside the tubular strut. This alteration can be applied to existing seats in the event of any complaint of splitting.

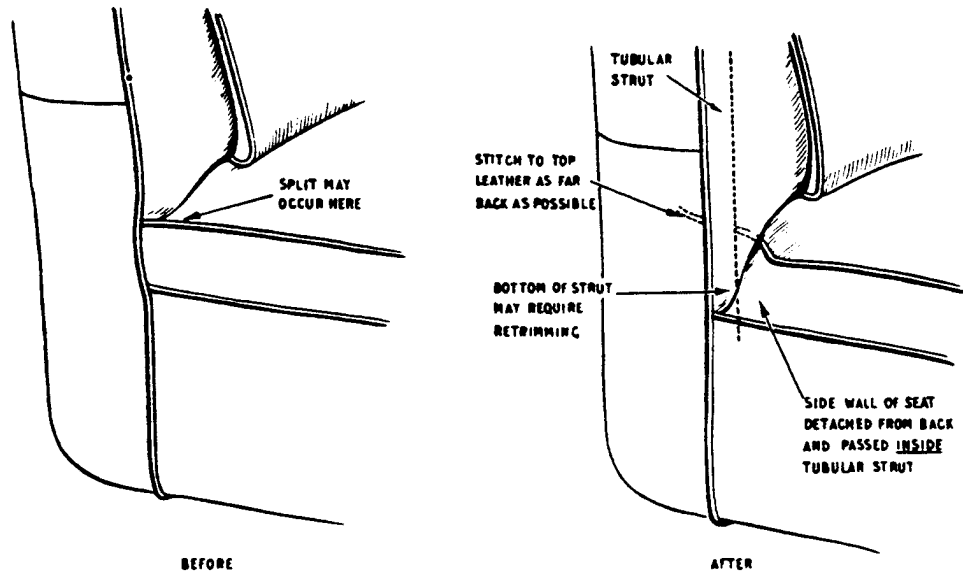

The procedure to adopt is as follows:-

1. Remove seat back millboard with carpet and hide.
2. Take side wall of seat cover inside the tubular strut and "french" securely to the top of the cover and piping. (This will allow the side wall to flex with the seat cover instead of being constrained by the tubular strut.)
3. It may be found necessary to cut a small portion of surplus hide from the rear of the cushion cover to enable you to cover a portion of bare tube which may be left exposed. This is only a matter of an inch or so of hide and may not be necessary in all cases.
4. Replace the millboard seat back together with the carpet, using the same seat back hide which is also refrenched round the top edge of the seat back.

ALL COMMUNICATIONS SHOULD BE ADDRESSED TO  
BENTLEY MOTORS (1931) LTD. SERVICE STATION, MYTHE ROAD, WILLESDEN, LONDON, N.W.10

SECTION

**Bulletin**

MODEL: BENTLEY MARK VI

MODIFICATION.FRONT WING MUD FLAPS.

Front wing mud flaps are now fitted to all cars being manufactured with Bentley standard coachwork.

Prior to this modification, a few cars have been delivered for service on which mud flaps were not fitted, and Retailers are advised that modification sets are available on application to this Service Depot should owners of these cars wish to have them fitted.

The mud flaps are fitted to the rear underside of the front wings, the method of attachment being by angle plates and 2-BA bolts and nuts, the positioning of these may be noted from the attached drawing.

Would Retailers kindly inform this Service Depot concerning chassis numbers of individual cars on which they carry out this alteration.

# Bulletin

MODEL BENTLEY MARK VI

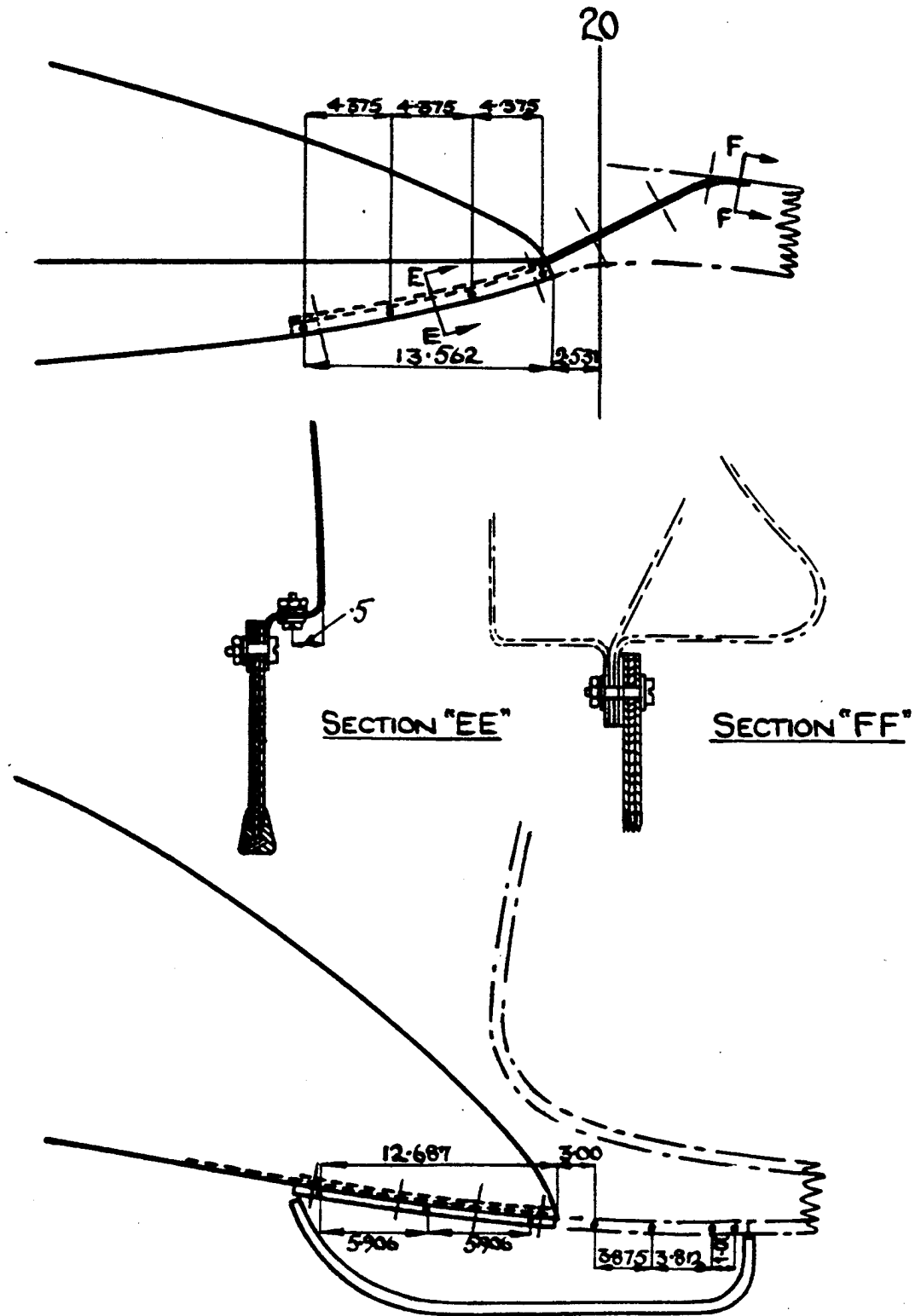

ALL COMMUNICATIONS SHOULD BE ADDRESSED TO BENTLEY MOTORS (1931) LTD. SERVICE STATION, 117/119 ROAD, LONDON, W.14

**Bulletin**

MODEL: BENTLEY MARK VI

MODIFICATION.FOR CATEGORY 2 ACTION:DOOR STRIKER PLATES.

A modification has been introduced to provide an improved type of striker plate for the door locks of the Bentley Standard Saloon. The modified door striker plate embodies a solid safety catch in place of the spring loaded safety catch in the original fitting.

This alteration will now be incorporated on all Standard Saloons. On earlier models, the modified striker plate should be fitted retrospectively when cars become available at service stations.

Arrangements have been made for a number of the new striker plates (Part No. RB-4228) to be forwarded to Retailers who have Bentley Standard Saloons in their area. In the event of further supplies being necessary, they may be obtained from the London Service Depot.

WATERPROOFING OF SCUTTLE TYPE VENTILATOR.CATEGORY:3A.

The following description of a method of improving the sealing of the scuttle ventilator is provided for the information of Retailers, so that action may be taken in cases of complaints of leaks.

Briefly, this consists of fitting a new rubber seal, smoothing off with paint fillers etc. the underside of the ventilator lid which contacts the rubber seal, and then, very carefully re-assembling the ventilator to ensure 100% contact with the rubber seal when in the closed position.

New rubber seals (Part No:RB-2514) are obtainable from Hythe Road Service Station.

The recommended procedure is as follows:-

- (i ) Detach the instrument panel from its mounting by first removing the wood facia which is retained by three screws at the top, and two screws along the bottom edge, and then remove the screws securing the instrument mounting plate. The mounting plate together with the instruments can then be pulled clear sufficiently to gain access to the underside of the ventilator. It will now be possible to disconnect the operating lever from the ventilator, by removing the small bolt and the two locknuts.
- (ii ) With the ventilator in the open position, remove the two screws which are fitted at each side of it (and accessible from outside the car) and then lift off the ventilator.
- (iii) Remove the existing rubber sealing strip which has probably become flattened in places, and then check that the water drain pipe from the ventilator trough is free from obstruction. If there is a partial blockage, it may be due to an excessive quantity of adhesive being used for sticking the rubber drain pipe in position. The rubber drain pipe can be removed in order to see if this is the trouble. When refitting the pipe, it is not necessary to use an adhesive.

**Bulletin**

MODEL BENTLEY MARK VI

- 2 -

- (iv) Stick the new rubber sealing strip in position with Bostik or other suitable waterproof adhesive. This operation will have to be very carefully carried out, as it is possible to stick the rubber in position in such a way that the lip is level with the main body of the seal instead of sticking up above it. (See illustration)

Also, before allowing the adhesive to set, make sure that the rubber is so positioned that it will contact the lip of the ventilator all the way round. This can easily be checked by placing the ventilator in position and then trying to rock it.

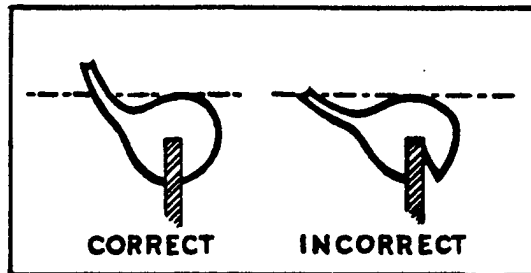

Section through rubber seal, showing correct methods of sticking seal in position.

- (v) Examination of the underside of the lip of the ventilator will show that there are depressions at each corner caused by the cut-away of the sheet metal before turning over the lip. These depressions prevent a good seal being made with the rubber, so it will be necessary to fill them in with paint fillers in order to make the surface smooth and flat.
- (vi) When refitting the ventilator, great care should be taken to ensure that it is accurately positioned in relation to the rubber seal before the four screws which secure it to the hinge are tightened. These screws pass through clearance holes which allow a limited amount of adjustment to the position of the ventilator, thus enabling an even pressure on the rubber seal to be obtained in the closed position.

It is recommended that a test is carried out by pouring water over the ventilator in order to check that an effective seal has been obtained.

Will all Retailers kindly notify this Service Station of the Chassis Nos. of cars on which this work is carried out.

FOR INFORMATION:SUN VIZOR BRACKETS.

This Bulletin is issued for guidance in adjusting sun vizor hinges which are either too tight to operate or have worked loose.

The illustration shows an exploded view of the assembly, and adjustment should be made as follows:-

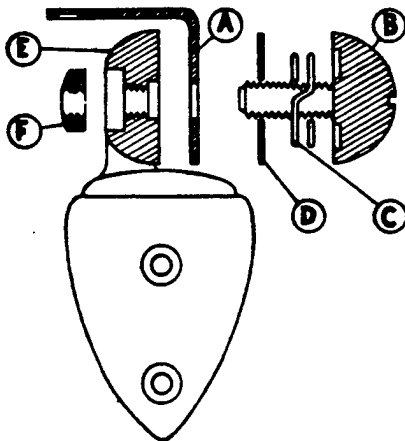

- A. STATIONARY BRACKET.
- B. ADJUSTABLE SPINDLE.
- C. THACKERY WASHER.
- D. BRASS SLIPPING WASHER.
- E. NUT FOR SPINDLE
- F. LOCK NUT.



**TOOL FOR ADJUSTING LOCK NUT 'F.'**

1. With the lock nut (F) loose, screw in B as far as it will go. This should completely lock the assembly.
2. To obtain the correct amount of friction, unscrew B slightly, the precise amount can be determined by testing the movement of the vizor, but it will be approximately  $\frac{1}{4}$  turn. Tighten the lock nut with a forked screwdriver as tightly as possible.
3. Increase the locking action by further unscrewing B very slightly, at the same time turning the lock nut with it. The friction of the bolt and nut thread is thus used to help the lock nut to tighten up an extra fraction of a turn against E.

The brass washer D may not always be found on early chassis Nos. and if this is the case, a similar washer should be fitted about .025" thick. This prevents the end of the Thackery washer C from biting into the bracket.

All replacement Sun Vizor hinges are supplied with this washer fitted.

**Bulletin**

MODEL BENTLEY MARK VI

DOOR SEALS - OUTERINTRODUCTION OF NEW TYPE.FOR INFORMATION:

A new type of sealing rubber for the outer edge of all doors in the standard saloon has been developed, and it is desired to fit this new seal to customers' cars if trouble with the existing seals is encountered.

The new seal is a very soft, white, sponge rubber, roughly triangular in section, as shown at 'A' on the diagram and the apex of the triangle forms the contact point for the door, except in the special instance of the trunk door (see later). Owing to its spongy nature, the rubber is very susceptible to oil or grease.

The seal is held in position by the ordinary Bostik 'C' adhesive No.252, and it is essential when applying to make sure a liberal quantity enters the groove in the base of the seal. The adhesive should be applied both to the seal and to the channel in the body which is to receive the seal. The best results are obtained if the adhesive is allowed to get tacky before finally pressing the two surfaces together.

When applying the rubber to the main doors, start at the centre post at the top corner (C) where a mitre joint is essential, then work downwards a short distance at a time, making sure that the apex of the section is lying in a straight line, owing to the extreme flexibility of the rubber this requires care. Only right-angle bends need a joint as the rubber will accommodate the others. The action of the door shutting tends to push the seal sideways, particularly on the length above the top hinge on the centre door post, so it may be found necessary to reduce the volume of the rubber by cutting a thin layer off the base of the triangular section with a pair of scissors. This operation must be carried out before the adhesive is dry and the seal must be pulled away carefully as it readily tears.

The lower edge of the trunk door (D) which makes a joint with the upper edge of the spare wheel compartment lid requires the special treatment shown on the diagram whereby the rubber is applied lying sideways, as there is insufficient room for the rubber to be applied normally if the spare wheel compartment lid is to shut properly.

Although the new rubber has greater flexibility than the old (B), it may be necessary to adjust the door striker plates to obtain good matching of the doors with the body shell and a good door shutting action.

Existing seal:- Part Number RB 2550

New seals:-	Part Number	RB 4357	Front door, outer, 2 off.	length	108"
	" "	RB 4358	Centre post, centre	4 "	" 16"
	" "	RB 4359	Centre post, lower	4 "	" 10"
	" "	RB 4502	Centre post, upper	4 "	" 24"
	" "	RB 4360	Rear door, outer	2 "	" 111"
	" "	RB 4361	Trunk door, upper,	1 "	" 74"
	" "	RB 4362	Trunk door, lower,	1 "	" 40"
	" "	RB 4363	Spare Wheel, door,	1 "	" 64"

Adhesive:- Bostik 'C' No:252

ALL COMMUNICATIONS SHOULD BE ADDRESSED TO  
BENTLEY MOTORS (1931) LTD., SERVICE STATION, HYTHE ROAD, WILLESDEN, LONDON, N.W.10

SECTION U.

# Bulletin

MODEL: BENTLEY MARK VI

- 2 -

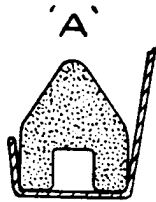

NEW SEAL NORMALLY APPLIED

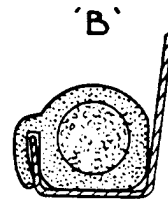

EXISTING SEAL

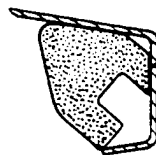

TRIM AS NECESSARY

NEW SEAL LYING SIDWAYS AS APPLIED TO TRUNK DOOR, EDGE 'D'

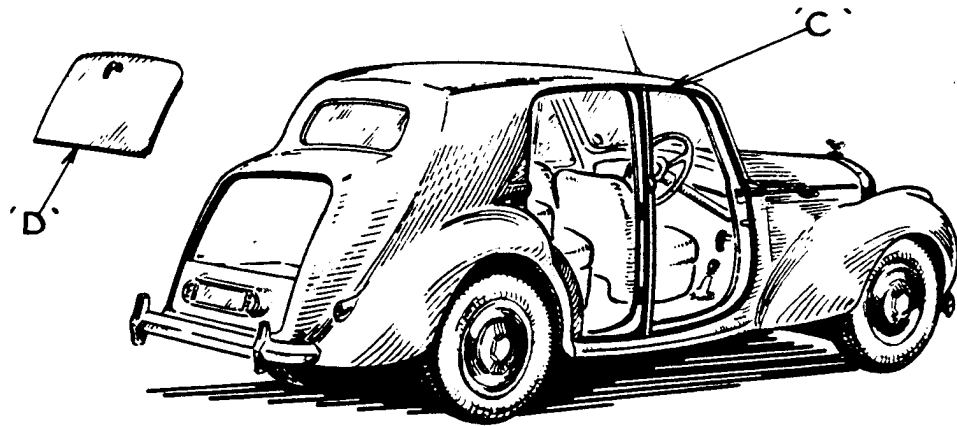

ALL COMMUNICATIONS SHOULD BE ADDRESSED TO  
BENTLEY MOTORS (1931) LTD. SERVICE STATION, HYTHE ROAD, WILLESDEN LONDON, N.W.10

FOR INFORMATION:CUTTING OF DOOR SEALING RUBBERS.

Cases have occurred in wet weather where drain water from the doors has "built-up" on top of the lower door sills of Standard Saloons.

Investigations have shown, that in all these cases, the cars concerned were fitted with the later type soft sponge, triangular section door sealing rubbers, and that the natural tendency for this sponge rubber to spread rendered it impossible for the waste water to drain away while the doors were closed.

In order to compensate for this tendency to spread, and at the same time provide adequate means for drainage during wet weather, all current Standard Saloons in production have the bottom sealing rubber along the outer edges of the sills "cut back", leaving a gap of approximately  $\frac{1}{4}$ " at the point of juncture with the vertical sealing strip at the foot of the centre door pillars as shown in the attached sketch.

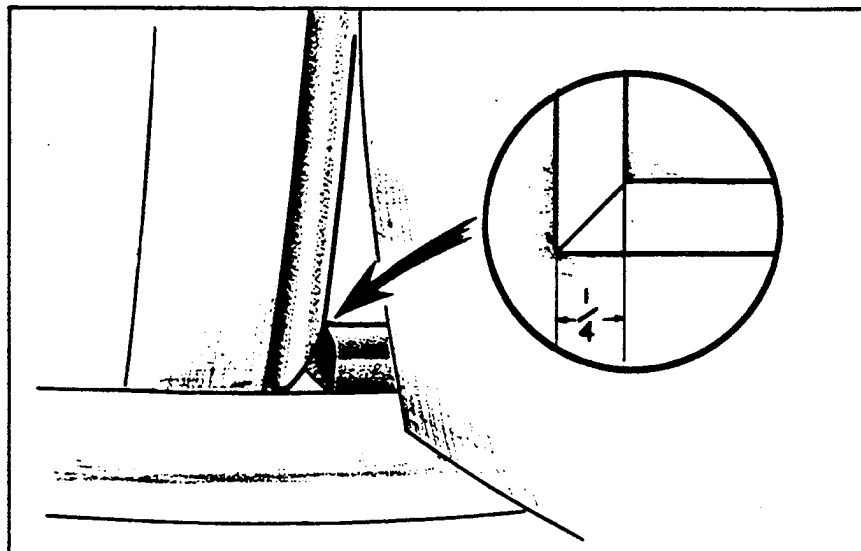

Retailers are advised, therefore, when dealing with complaints of such a nature from owners of earlier models of Standard Saloons, to cut the existing lower door seals to conform with the current procedure.

**Bulletin**

MODEL BENTLEY MARK VI

MODIFICATIONFOR CATEGORY 1 ACTIONDOOR STRIKER PLATES

The original spring loaded door striker plates have been the subject of modification action under Service Bulletin BB-30, whereby a solid striker plate was fitted on a Category 2 basis. At the same time, these striker plates were introduced on cars at the factory prior to delivery.

The safety catch on the solid striker plate is rather shallower than on the spring loaded catch, and it has been discovered that owing to variations in the projection of the bolt, the depth of engagement on the safety catch may not be quite sufficient, although there is in every case adequate engagement with the main catch when the door is closed.

It has been decided to check all cars fitted with solid striker plates, and if necessary increase the depth of engagement of the bolt, by suitable packing of the striker plate.

Will Retailers please take immediate Category 1 action to inspect all cars in their territory for this feature. The correct procedure for checking and correction is as follows:-

- (i) Check the amount of free movement of the external handle before moving the bolt when the door is open.
- (ii) Close the door on to the safety catch only.
- (iii) Check the free movement of the handle before moving the bolt. This must be at least  $\frac{1}{4}$ " more at the end of the handle as compared with the door open free movement.
- (iv) If this free movement is not obtained in the safety catch position, pack out the door striker plate suitably.
- (v) Aluminium packings, RB.4705,  $\frac{1}{10}$ " thick are in course of manufacture, and will be available in the near future. In the meantime, will Retailers make suitable packings from sheet aluminium.
- (vi) It is permissible to fit two packings if necessary to obtain the conditions described above, making a total thickness of packing of .200".
- (vii) Inform this Depot of all chassis numbers attended to.
- (viii) New cars delivered subsequent to the date of issue of this Bulletin will have been attended to.

**Bulletin**

MODEL BENTLEY MARK VI

- 2 -

- (ix) The substitution of solid striker plates for the original spring loaded striker plates will continue on a Category 2 basis as already instructed under Bulletin BB-30. The above adjustment, will, of course, have to be carried out at the same time.
- (x) Certain cars may be found to have fibre packings behind the striker plate. These should be removed and aluminium packing substituted.

In addition, it may be necessary to pack out the male portion of the door dovetail. In this case, the amount of engagement can be determined by visual examination, since there will be a distinct marking on the wedge. If the engagement is less than  $3/16$ " , a packing, similar to that used on the striker plate should be fitted under the dovetail.



MODEL BENTLEY MARK VI

FOR INFORMATION:

FITTING LOCKS TO BONNET  
STANDARD STEEL SALOON.

This Service Bulletin supersedes Bulletin No.BB-57 (Section U) dated the 25.10.48, which should be destroyed.

The following information is given for the assistance of Retailers who may be requested by an owner to fit locks to the bonnet of his car

PARTS REQUIRED:

Part No.	Title.	No.Off.	Part No.	Title.	No.Off.
E-56084	Lock(Vaughan)	2	K-4103	Nut.	6
R-4041	Socket plate.	2	CS-30077	Screw.	8
RE-4903	Cover plate.	2	CS-30975	Nut.	8
RE-4862	Bolt.	6	CS-6728	Washer.	8
RE-4860	Distance piece.	2	CS-35081	Split rivet.	4
K-9003N	Washer.	6			

FITTING INSTRUCTIONS:

Note: The datum line for marking off purposes is the centre line through the centre of the shank of the bonnet handle as shown in Figs. 1 & 2.

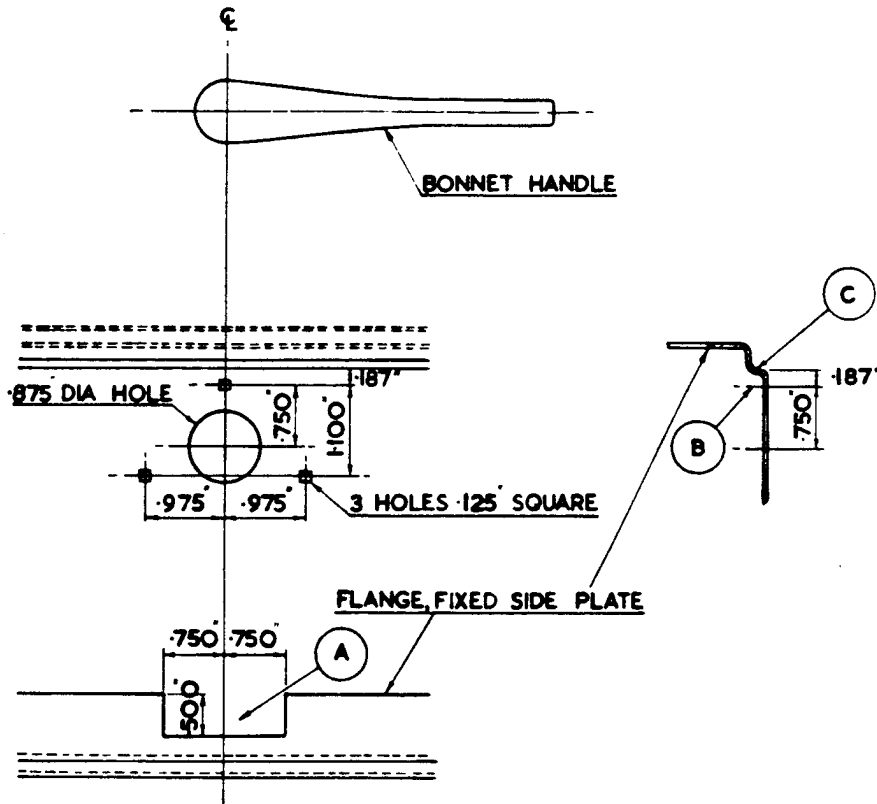

FIG. 1. DRILLING INSTRUCTIONS - BONNET LOCK.



- 2 -

- (i) Cut a slot, 'A' Fig.1, in the flange of the fixed side plate as shown.
- (ii) Mark off and drill the fixed side plate as shown in Fig.1. It is important that the 0.187" dimension (from the ledge 'C', of the side plate to the centre line 'B') should be adhered to closely to ensure that the distance piece (5) & lock are located as high as possible inside the fixed side plate as shown at point 'A' Fig.2.
- (iii) Lightly radius the distance piece at point 'A' (Fig.2) and with it in position on the lock, temporarily fit the lock to the side plate and check for being square. The three square holes may be trimmed slightly to provide adjustment.

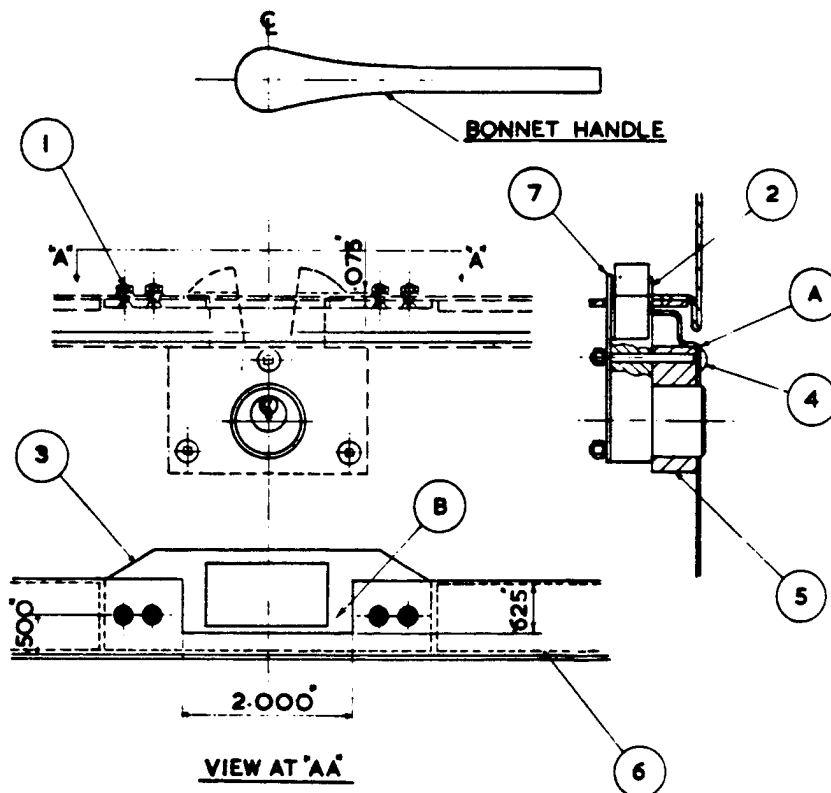

FIG. 2. ARRANGEMENT OF BONNET LOCK.

- (iv) Check that there is a clearance of approximately 0.062" between the face of the lock and the slot in the flange.
- (v) Fit the lock assembly and repeat for the opposite side.
- (vi) Remove the bonnet and cut away the bonnet rest tape on the flange 2.500" either side of the centre line, leaving a gap 5.000" wide to accommodate the lock socket plate (3 Fig.2).

**Bulletin**

MODEL: BENTLEY MARK VI

- 3 -

- (vii) Cut a slot 'B' Fig.2, in the flange of the bonnet as shown.
- (viii) Place the lock socket plate on to the flange. With the plate correctly centered and bearing against the side of the bonnet, drill four holes 0.125" diameter in the flange, using the plate as a template. Fit the plate. Drill a further hole 0.125" diameter and fix the loose end of the tape with a split rivet.

NOTE: When the lock and its socket plate have been fitted, there should be a clearance of not less than 0.075" between the jaws of the lock and the socket plate as shown in Fig.2. With the bonnet handle in the open position and the bonnet locked, check for this clearance by lifting the bonnet. If there is insufficient clearance, then a thin packing plate may be fitted between the plate and the flange.

It is important however, that the socket plate remains below the surface of the tape, i.e. it must not make contact with the flange of the fixed side plate, otherwise the bonnet will rattle.

- (ix) Repeat for the opposite side.

**Bulletin**

MODEL BENTLEY MARK VI

FOR INFORMATION:REAR WING FAIRINGS.

Rear Wing Fairings are now available for fitting to models of the Bentley Mark VI Standard Saloon car already in service as a chargeable improvement.

Fig. 1, shows the finished appearance of a rear wing with a fairing fitted.

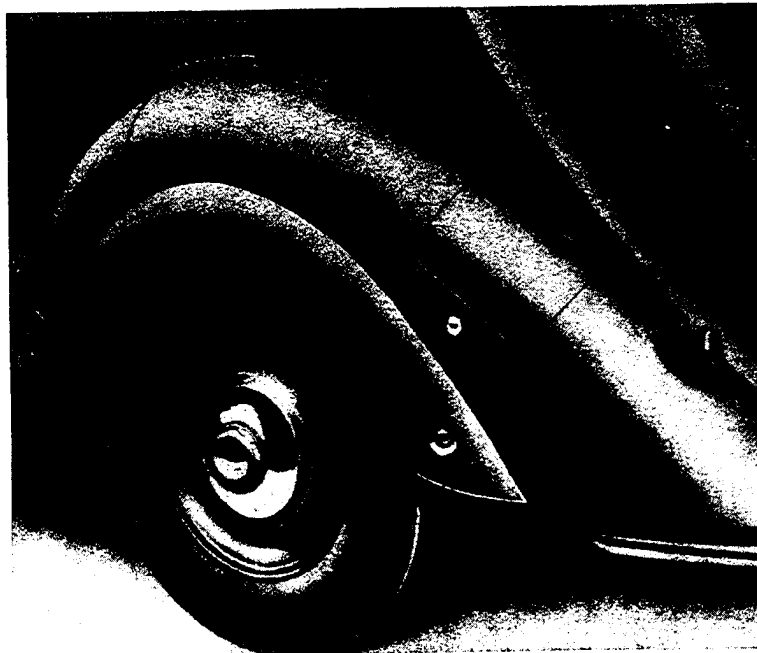

FIG. 1.

When these panels are fitted, removal will only be necessary for major repair work on the rear of the car. When the car is lifted on the jack provided, the rear suspension allows the wheel to drop sufficiently to give ample clearance to remove the wheel with the wing fairing in position.

The wing fairings are supplied finished in primer and must be sprayed to match the finish of the coachwork when fitting is completed.

PARTS REQUIRED:

<u>Part No:</u>	<u>Title:</u>	<u>No. Off:</u>
RB.4476A	Panel assembly. R.H.	1
RB.4477A	Panel assembly. L.H.	1
RB.4484	Escutcheon - Panel.	2
RB.4485	Bolt - Panel to rear wing.	2
RB.4486	Boss - Rear wing.	2
RB.4487	Washer - Escutcheon.	2

# Bulletin

MODEL: BENTLEY MARK VI

- 2 -

RB.4488	Securing ring - Escutcheon.	2
RB.4489	Securing ring - bolt.	2
RB.4504	Tongue(Dowel) - detachable panel.	4
RB.4506	Striker plate - tongue.	2
RB.4508	Striker plate - tongue.	2
RB.4510	Fixing strip - Rexine piping.	2
RB.4514	Rexine Piping - panel R.H.	1
RB.4515	Rexine piping - panel L.H.	1
KB.2462	Rivet - Striker plate.	16
CS.35206	Rivet - Tongue (dowel)	12
CS.35060	Rivet - fixing strip.	50

GENERAL:

When fitted, the wing fairing is secured at three points as shown in Fig. 2. Items 'A' and 'B' are tongue and slot fittings, tongues being fitted

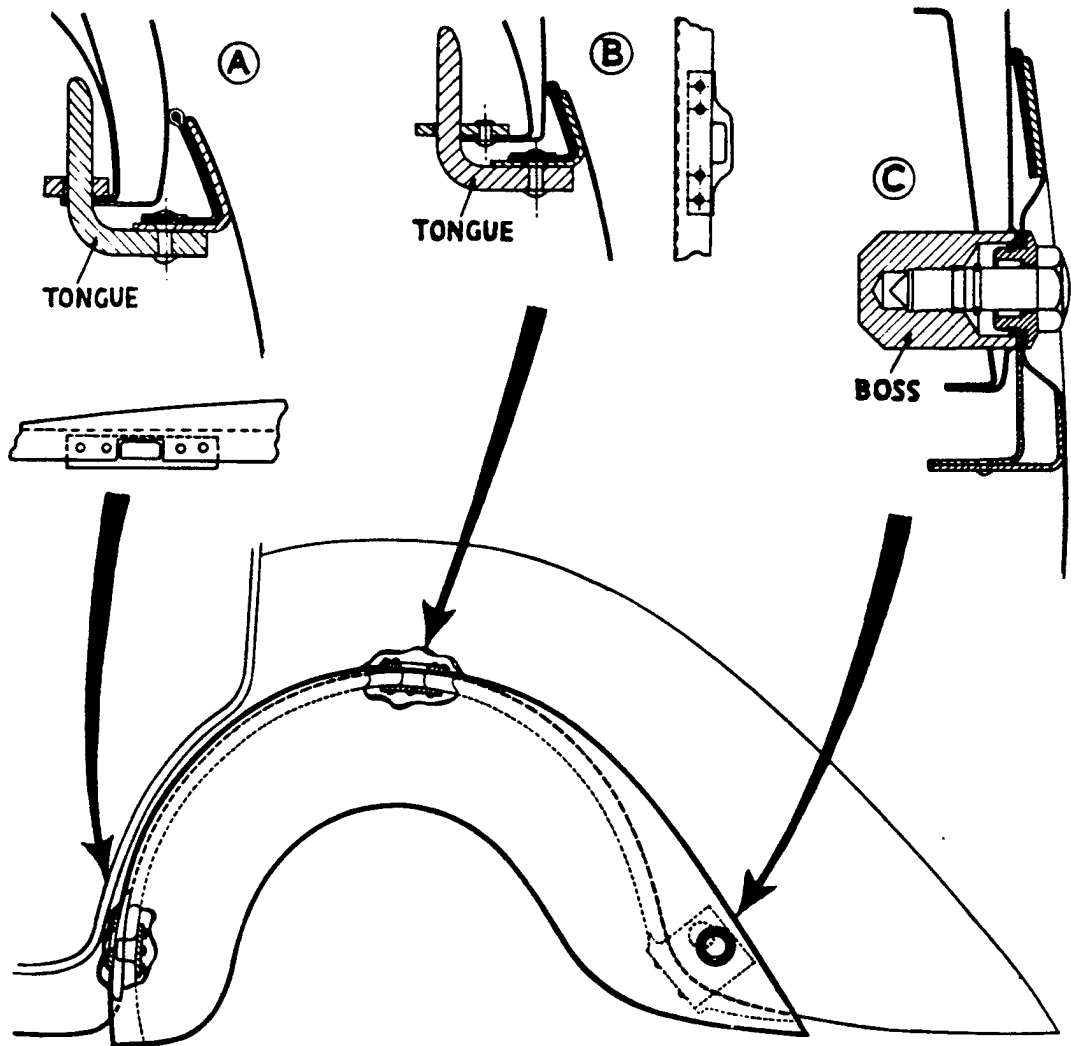

FIG. 2.

ALL COMMUNICATIONS SHOULD BE ADDRESSED TO  
 BENTLEY MOTORS (1931) LTD. SERVICE STATION, 11 THE ROAD, WILLSDEN, LONDON, N.W.10

**Bulletin**

MODEL: BENTLEY MARK VI

- 3 -

to the wheel fairing and slotted plates to the wing lip (flange). A sectional diagram of each fitting is also shown, together with the position of the slotted plates riveted inside the wing lip. The rear end of the fairing ('C') is secured by a bolt screwed into a threaded boss in the wing.

**PROCEDURE FOR FITTING REAR WING FAIRINGS:**

The following instructions and all diagrams dealing with this procedure are in respect of the left-hand side wing fairing to simplify descriptive matter. As both fairings and wing modifications are symmetrical, these instructions are therefore also applicable for the right-hand side of the car.

- (i ) Jack up the rear of the car, remove the wheel and clean the inside of the wing.
- (ii ) Mark off positions of 'A' and 'B' tongue centres on the outer edge of the wheel fairing as shown on Fig. 3. 'A' centre should be 4.000" from the bottom of the leading edge and 'B' centre equidistant from 'A' and 'C' centres on the outer edge of the fairing.

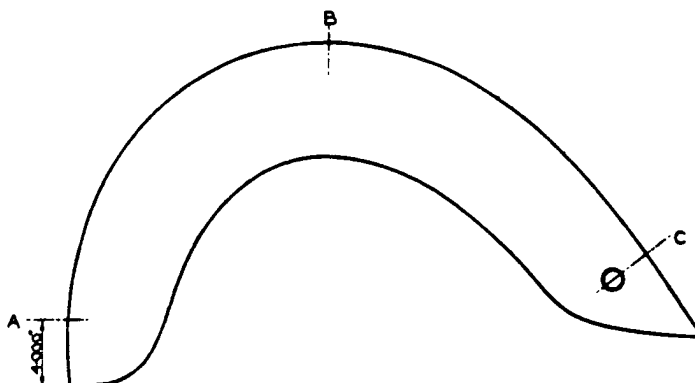

FIG. 3.

- (iii) Clamp the fairing into position on the wing. This should be such that both front and rear bottom edges blend into the wing and sufficient clearance given for the opening of the door i.e. the door must be clear of the beading of the Rexine piping when the latter is fitted to the fairing. The fitting of the piping is described in paragraph vi. Mark off the tongue centres on the lip inside the wing.
- (iv) Remove the fairing. Rivet the slotted striker plates in position on the inside wing lip - centres of slots to correspond with tongue centres. The rectangular striker plate is to be fitted in the forward position ('A' Fig.2) and as far inwards as the contour of the inner skin of the wing will allow.

# Bulletin

MODEL BENTLEY MARK VI

- 4 -

Part of the wing lip must be cut away to allow clearance around the slot in the striker plate (see 'A' Fig.2). This plate is slightly curved to follow the wing form, and the rivet holes are offset to allow the rivets to be fitted well inside the lip of wing. The position of the striker plates on the wing lip is also illustrated in 'A' and 'B', Fig. 2.

- (v) Rivet the tongues on to the stiffening web of the fairing. The sectional illustrations in Fig. 2 show the method of fixing. Before carrying out this operation, it is advisable to again clamp the fairing into position on the wing and re-check the tongue centres and ascertain the exact position to fit the tongues on the stiffening web to give a snug fit to the fairing when finally fitted.

**NOTE:** The fairing when clamped into position prior to fitting the tongues to it, should be a good flush fit against the wing and no gap should be left for the thickness of the Rexine piping. The tongues should be fitted so that the fairing is a good bump fit by hand with the piping fitted. If slacker, the fairing will rattle when finally assembled to the wing.

- (vi) Cut a series of vee's in the Rexine piping to prevent puckering and to enable it to be evenly placed on the inside of the fairing and on the stiffening web. The vee's should be cut about two inches apart from one another and up to approximately  $\frac{3}{8}$ " from the beading of the piping.

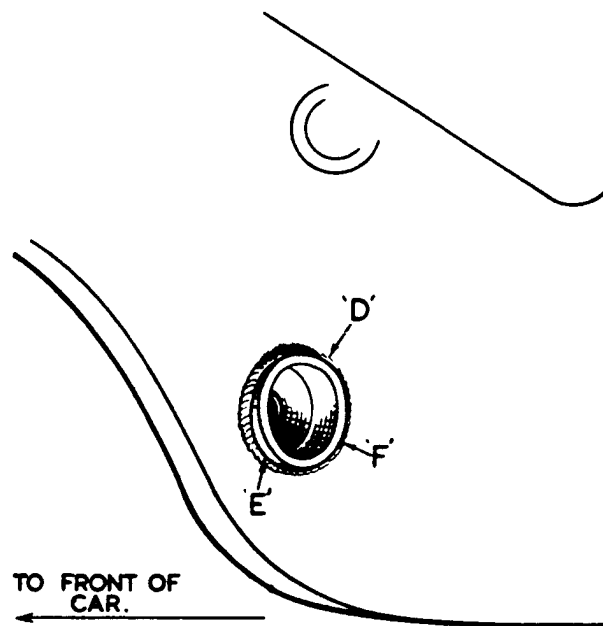

FIG. 4.

**Bulletin**

MODEL: BENTLEY MARK VI

- 5 -

Apply Bostik or a similar adhesive to that side of the piping which fits against the fairing. Place it in position on the fairing, with the beading projecting just above the outer edge as shown in 'A' and 'B', Fig.2. The pipings are handed. Place the metal fixing strip over the piping and the web of the fairing. Using the strip as a template, drill holes as necessary and then rivet the strip into position with the bifurcated rivets supplied.

- (vii) Refit the fairing making sure that the front and upper tongues have fully engaged in the slots of the plates and then re-clamp the fairing into final position. Check that the tongues project at least  $\frac{1}{4}$ " through the plates. Should difficulty be experienced in engaging the upper tongue with the slot in the plate, trim up the end of the tongue as necessary.
- (viii) The next operation is to fit and weld the boss 'F', Fig.4 (also shown in view 'C', Fig.2) in the appropriate position on the rear wing. It will be observed from Fig.4 that the outer face of the boss is nearer to the wing at point 'D', than at point 'E', in order to ensure that the rear end of the fairing fits snugly to the wing. To fit, proceed as follows:-
- a) With the fairing still clamped into its final position on the wing, scribe the position of the hole in the rear of the fairing on to the wing and remove the fairing.
  - b) Find the centre of the scribed circle on the wing, and from this centre, scribe another circle  $1-5/16$ " dia. Drill a series of  $\frac{1}{8}$ " dia. holes within this circle and also through the inner metal skin of the wing and remove the metal.
  - c) Trim the hole in the wing until the boss is a good push fit in this hole. Trim the hole in the skin (it is not necessary for the boss to be a good fit in this hole) to allow the boss to be tilted so that when the outer face of the boss is flush with the wing at point 'D' Fig.4, the face of the boss at point 'E' will project from the wing by approximately  $3/16$ ". To assist in positioning the boss, point 'D' should be approximately  $45^{\circ}$  from the vertical line.
  - d) Remove the boss and clean away paint as necessary on the wing for welding purposes. Push the boss into position until the face of it at point 'D', stands proud of the wing by about  $1/32$ " and at point 'E' by about  $3/16$ ". Weld the boss to the wing. Alternatively, the boss may be brazed to the wing.

ALL COMMUNICATIONS SHOULD BE ADDRESSED TO  
BENTLEY MOTORS (1931) LTD., SERVICE STATION, MYTHE ROAD, WILLESDEN, LONDON, N.W.8

SECTION

**Bulletin**

MODEL BENTLEY MARK VI

- 6 -

- (ix) Place the plated escutcheon on to the bolt and secure with the circlip. Place the rubber washer on to the escutcheon, fit these parts to the fairing and secure by fitting the circlip to the escutcheon. Again re-check the fit of the fairing on the wing. Remove the fairing. Mask the plated end of the bolt and the escutcheon and spray the fairing to match the finish of the coachwork. Clean up and re-cellulose wing as necessary.

FOR INFORMATION:FITTING OF THE AUTOMATIC VACUUM OPERATED WINDSCREEN WASHER UNIT.

Retailers are advised that an automatic vacuum operated windscreen washer unit is now available for fitting to existing models of Bentley Mark VI Standard Saloons as a chargeable improvement.

This fitting is recommended as an aid to improved driving comfort and safety, being particularly suitable for use on cars normally used for long distances where accumulations of mud, grime or dirt on the windscreen glass necessitate frequent stoppages for the purpose of obtaining clearer vision.

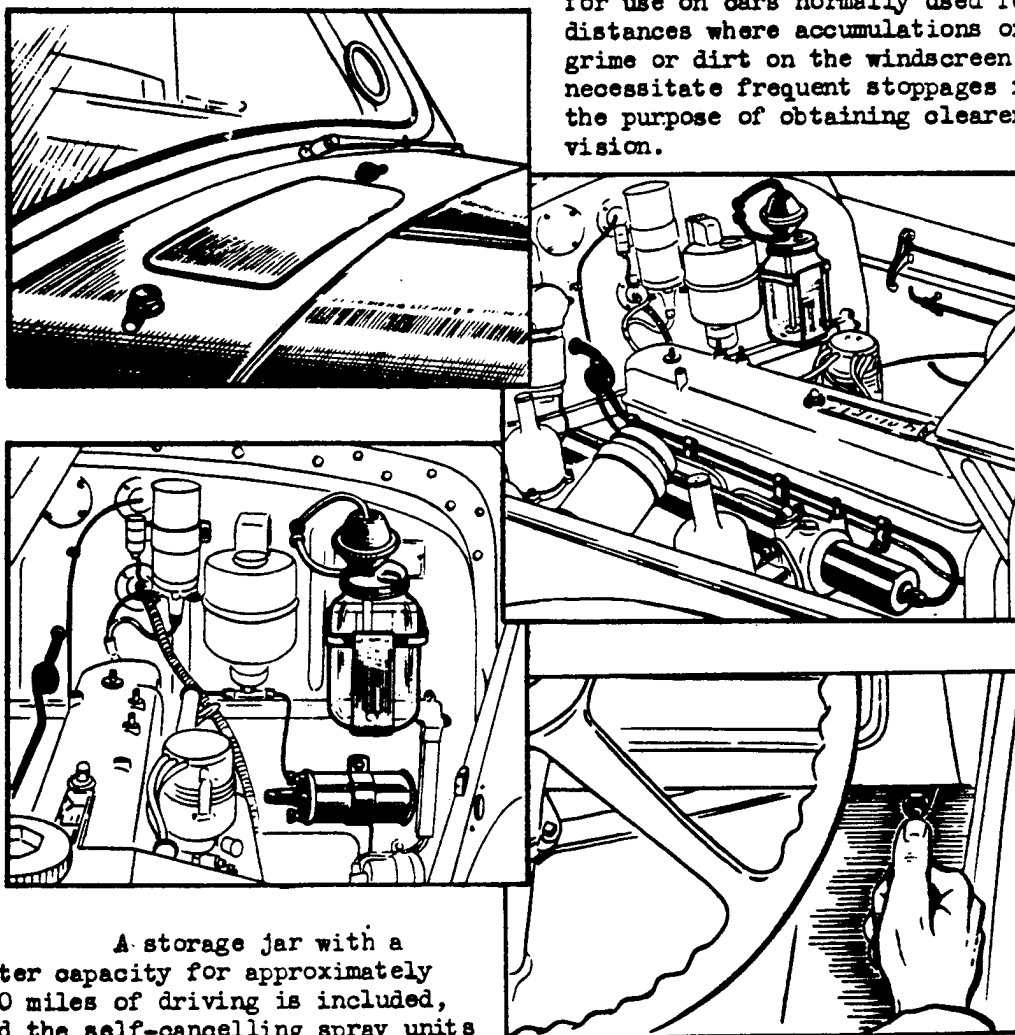

A storage jar with a water capacity for approximately 600 miles of driving is included, and the self-cancelling spray units are controlled through a single press-button which is conveniently positioned on the fascia panel within easy reach of the driver.

The general arrangement of the system when installed in a car is shown in the above illustrations. It should be noted however, that the use of the glass storage jar shown is only applicable where no Oil Bath Air Cleaner is fitted.

Should it be decided to fit a windscreen washer unit to a car with an Oil Bath Air Cleaner, it will be necessary for the special type of storage tank shown in Fig. 2 overleaf to be used.

# Bulletin

MODEL: BENTLEY MARK VI

- 2 -

## FITTING PROCEDURE.

### OPERATIONS:

1. Drill the dashboard as shown in Fig. 3.

a) The three holes "A" to be drilled for storage jar when no Oil Bath Air Cleaner is fitted.

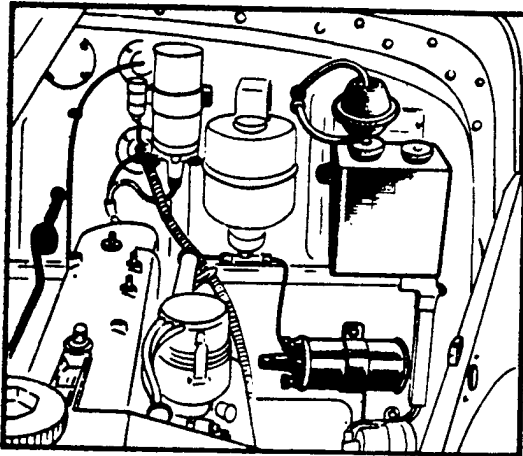

FIG. 2.

b) The two holes "B" to be drilled for the special type storage tank when Oil Bath Air Cleaner is fitted. (Remove the Oil Bath element and top cover assembly to facilitate drilling and subsequent fitting of tank to dashboard).

NOTES:- (i) Whether an Oil Bath Air Cleaner is fitted or not, the three holes "D" must be drilled.

(ii) On cars which have the spare ignition coil mounted vertically below the metal cable conduit, it will be necessary for the coil to be relocated as shown.

2. Fit the storage jar to the dashboard:-

a) Use the three 2-BA screws and nuts when fitting the standard glass jar.

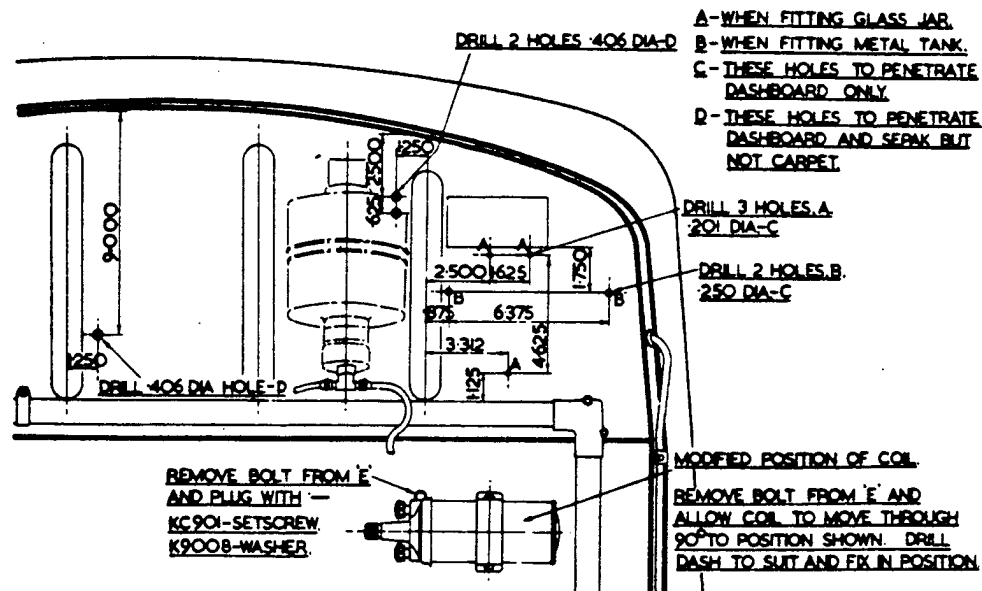

FIG. 3.

b) When fitting the special type storage tank, use the two special studs provided. The shoulders of these studs should be on the engine side of the dashboard.

# Bulletin

MODEL BENTLEY MARK VI

- 3 -

### 3. Fit the brass suction pipe to the induction manifold, (see Fig.1):-

- a) Remove the air silencer and then the existing core plug at the forward end of the manifold.
- b) Fit the special adaptor R-4109, (Aluminium Washer KB-1081), and connect up the suction pipe. Remove the nuts from the studs carrying the existing thermometer capillary tube retaining clips, and fit the four suction pipe clips.
- c) Refit the air silencer (and Oil Bath if fitted).

### 4. Drill the scuttle as shown in Fig.4:-

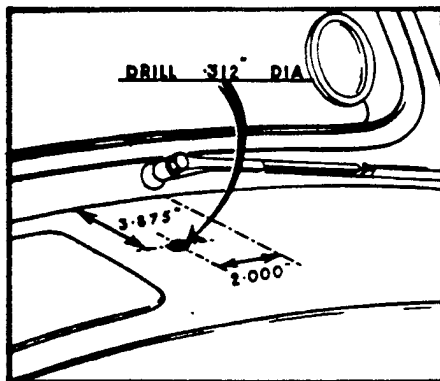

FIG. 4.

NOTE: Prior to drilling, remove the following:-

- (i) Radio Set: Disconnect the aerial and power feed, (and bonding tape if fitted), and remove the fixing screws.
- (ii) Radio Mounting Tray: Remove the six retaining screws, three countersunk headed on the left-hand side, and three cheesehead on the right-hand side.
- (iii) Withdraw the tool tray.

To ensure concentricity of the holes in the underskin of the scuttle with those drilled in the top panel, it is recommended that the operator continues drilling after penetrating the top panel.

- a) Open out the two holes in the underskin to 0.7187" (18.26 m/m) and fit the two rubber grommets D-74723 provided.

### 5. Fit the Control Valve below the right-hand glove box as shown in Fig.5:-

- a) Remove the existing angle bracket screws from the back of the fascia board.
- b) Assemble the control valve and mounting bracket and slide the top of the bracket up between the back of the fascia board and the angle bracket.
- c) Adjust the position of the Control Valve mounting bracket to give a clearance of  $3/16"$  (4.75 m/m) between the bottom edge of the fascia board and the hexagonal lock nut as shown. Using the existing angle bracket as a template, mark off positions for the two retaining screws on the Control Valve mounting bracket. Remove this and drill accordingly.

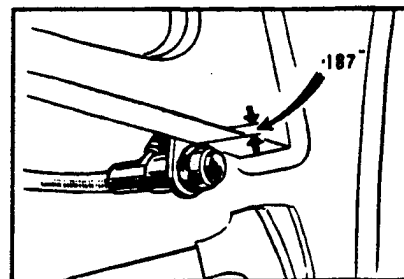

FIG. 5.



MODEL BENTLEY MARK VI

- 4 -

- d) Refit the Control Valve and its mounting bracket between the angle bracket and the back of the facia board. Secure both the brackets together by means of the longer wood screws provided, using one of the original angle bracket screws for the purpose of fixing the top of the mounting bracket.

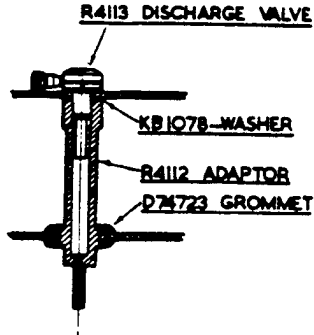

FIG. 6.

6. Fit the two spray units as shown in Fig.6:-

NOTE: To obviate the possibility of a leakage developing, it is recommended that the threads are treated with a suitable sealing compound.

7. Install the various lengths of rubber hosing as shown in Fig. 7:-

NOTE:- To avoid kinks, it is recommended that the holes which have been drilled through the sepak are suitably radiused off on the driver's side.

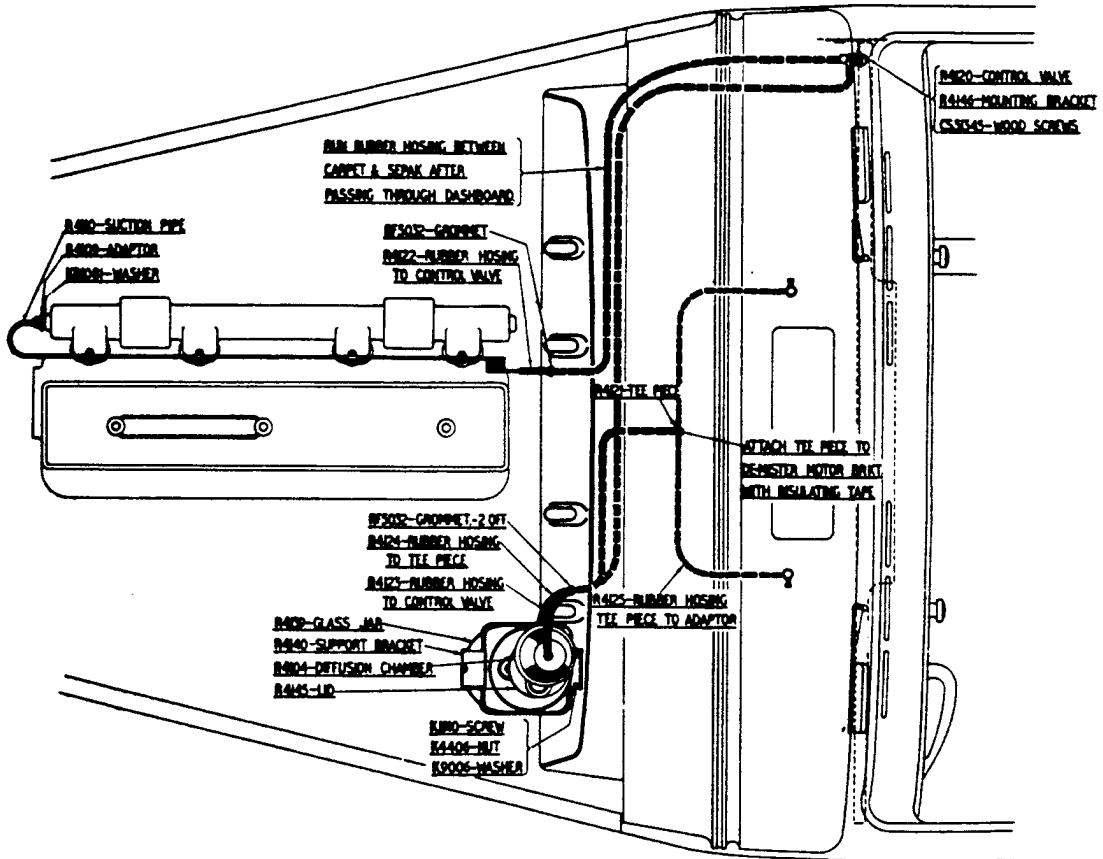

FIG. 7.

- 5 -

8. Fill the storage jar/tank with clean water, start up the engine, and test for correct functioning of the spray units.

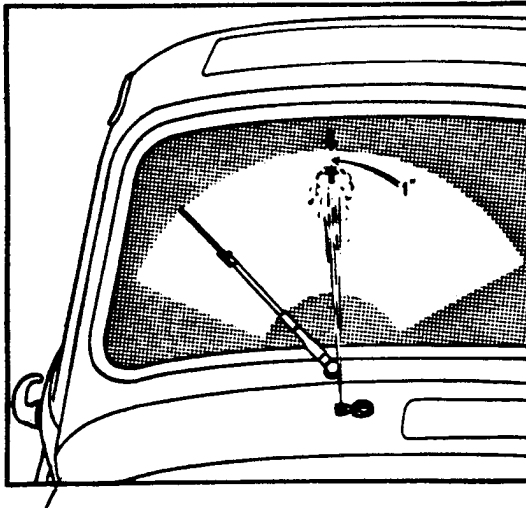

FIG. 8.

A certain amount of adjustment will be required to ensure that the two jets of water impinge on the windscreen both centrally and at approximately 1" below the highest point of each respective wiper arc as shown in Fig. 8.

The first essential will be obtained by initially fitting the spray units to the scuttle with their nozzle arms set forward approximately  $12\frac{1}{2}^{\circ}$  relative to the lower windscreen beading.

To obtain the correct degree of jet elevation, the complete nozzle arm will require to be either further tightened up or slackened back in the spray unit.

Of these, the former method is preferable, but should it be found necessary for the arm to be slackened back further, it is recommended that the threads are treated with a suitable sealing compound as a preventive against leakage.

**Bulletin**

MODEL BENTLEY MARK VI

- 6 -

PARTS REQUIRED.

When fitting a Windscreen Washer to a car not incorporating an Oil Bath Air Cleaner, the following parts will be required:-

R.4144	Standard Kit(Trico) Windscreen Washer.	1 Off
K.1910	Screws, Retaining 2-BA x 3/4" - Storage Jar.	3 Off
K.4307	Nut, for Retaining Screws 2-BA.	3 Off
K.9006	Washer, Spring for Retaining Screws.	3 Off
R.4109	Adaptor, Induction Manifold.	1 Off
KB.1081	Washer, Aluminium for Induction Manifold Adaptor.	1 Off
RF.5032	Grommet, Rubber for Rubber Hosing through dash.	3 Off
R.4112	Adaptor, Spray Units.	2 Off
D.74723	Grommet, Rubber for Spray Unit Adaptor.	2 Off
R.4110A	Brass Suction Pipe c/w Clips.	1 Off
KB.1078	Washer, Aluminium for Spray Unit Adaptor.	2 Off
R.4137	Bracket, Mounting for Control Valve.	1 Off
CS.31345	Screws, Wood for Control Valve Mounting Bracket.	2 Off
KC.901	Stud, Set for blanking dash.	1 Off
K.9008	Washer, for Set.Stud.	1 Off

When it is decided to fit a Windscreen Washer to a car with an Oil Bath Cleaner, the following parts will be required, in addition to those detailed above:-

R.4101	Storage Tank - Modified Type.	1 Off
R.4103	Cap, Screwed for Diffuser Chamber - Storage Tank.	1 Off
R.4106	Cap, Filler - Storage Tank.	1 Off
R.4107	Stud, Shouldered, Tank Retaining.	2 Off
K.4008/Z	Nut, for Shouldered Retaining Stud.	4 Off

NOTE:- When using the above, the following items normally included in the Standard Kit, R-4144, will not be supplied:-

Glass Storage Jar.  
Screwed Cap for Glass Storage Jar.  
Mounting Bracket, Glass Storage Jar.

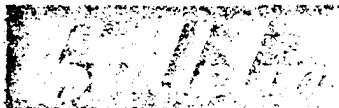

BENTLEY MARK VI

FOR INFORMATION:ALTERATION TO EXISTING PARTS & PART NUMBERS.(SUPERSEDES PREVIOUS ISSUE DATED 4.11.49).

Subsequent to the publication of Service Bulletin BB-66, certain modifications to the existing brass suction pipe and induction manifold adaptor have been effected.

Due to the additional experience gained since the introduction of the Vacuum Operated Windscreen Washer on existing Bentley Saloons, the three 1.00" coils at the dash end of the original suction pipe assembly have been deleted, and at the same time the internal diameter of the pipe itself has been increased. The new pipe assembly has been allocated a fresh part number (R-4103), and replaces the original pipe assembly (R-4110A).

In view of this increase in pipe diameter, it has also been necessary to provide a new adaptor for the forward end of the induction manifold, the part number of the new adaptor being R-4248, replacing R-4109 as previously stated.

It has now been decided to include these two new items in the Standard Kit (Trico) Windscreen Washer, thus making it unnecessary for individual ordering as previously stated on Page 6 of the original leaflet.

It is however, pointed out that the four suction pipe retaining clips are now separate items, and must be ordered individually, quoting the following new part number:-

R-4276.            Clip for Suction Pipe & Thermo Cable.            4 Off.

A further alteration in part numbers is also brought to the notice of all Retailers, this being as follows:-

Bracket, Mounting for Control Valve.            (R-4146 in place of R-4137)

Will Retailers please amend their existing issues of Service Bulletin BB-66 to conform with the above information.

The fitting instructions laid down in the original issue of this leaflet are not affected in any way by the alterations mentioned above.

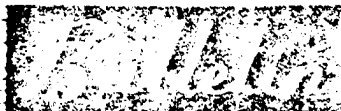

MODEL BENTLEY MARK VI

**FOR INFORMATION:****ADDENDUM TO FITTING INSTRUCTIONS GIVEN IN SERVICE BULLETIN RB-66.**

Subsequent to the publication of Service Bulletin BB-66, it is felt that a certain degree of uncertainty exists regarding the correct manner of fitting the two runs of rubber hosing between the diffusion chamber and the control button and tee-piece on the spray unit line.

With this in mind, it has been decided to clarify the diagrammatic instructions given in Fig. 7, page 4, of the original issue.

Retailers are advised, when fitting an Automatic Vacuum Operated Windscreen Washer Unit, to ensure that the run of hosing from the top adaptor of the diffusion chamber is connected to the control valve on the fascia, and that the tee-piece on the spray unit line is connected to the lower adaptor of the chamber.

Failure to observe this will only result in the functions of these two units being reversed, i.e. air being expelled through the spray nozzles and water being injected into the induction manifold.

**Bulletin**

MODEL: BENTLEY MARK VI

**FOR INFORMATION:****THE TRICO VACUUM OPERATED WINDSCREEN WASHER.****(APPLICABLE TO RIGHT-HAND & LEFT-HAND BENTLEY MK.VI)****(Supersedes Previous Service Bulletin BB-66c, 16.10.50).**

Retailers are advised that the Trico vacuum operated windscreen washer system incorporated on current right and left-hand drive chassis in production is now available for fitting to earlier models in service as a chargeable improvement should owners desire it.

This fitting is recommended as an aid to improved driving comfort and safety, being particularly suitable for use on cars normally driven over long journeys where accumulations of mud, grime or dirt on the windscreen glass necessitates frequent stoppages for the purpose of cleaning the screen.

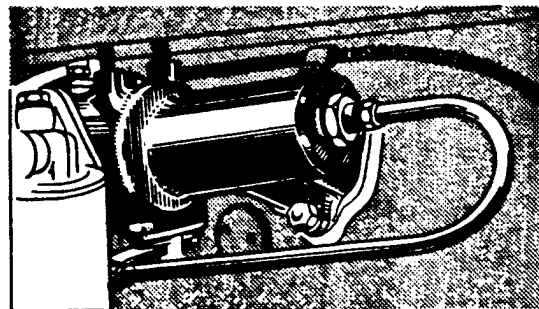
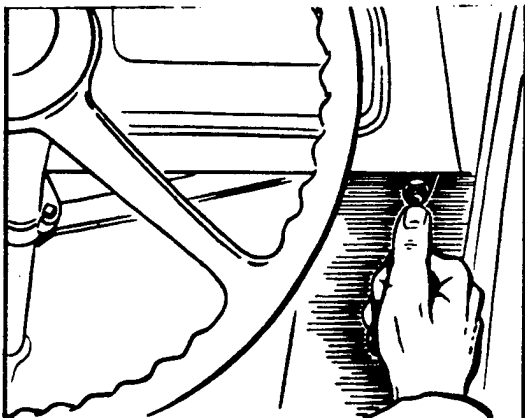
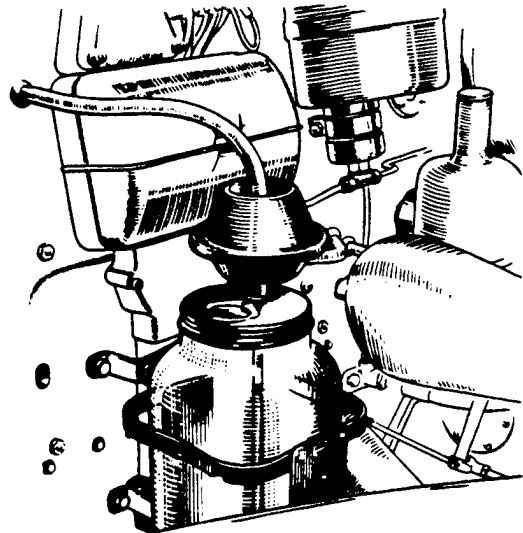
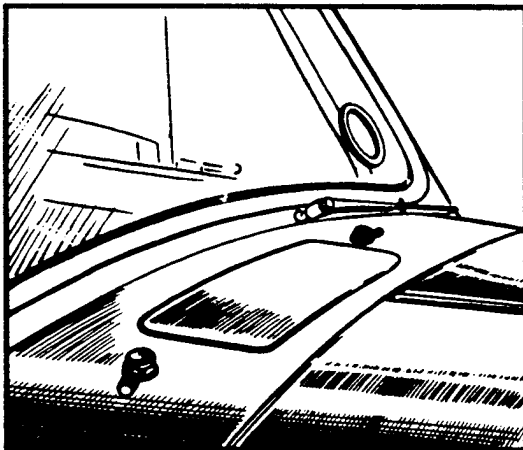

The equipment consists of two self-cancelling jets, mounted on the scuttle just forward of the windscreen

wiper blades, and controlled through a single press button conveniently situated within easy reach of the driver on the right-hand side of the facia board on right-hand drive cars (left-hand side on left-hand drive vehicles.) On pressing this button, the induction depression from the manifold is communicated to the diaphragm of the pump on top of the reservoir, which is a glass container fitted to the dash under the bonnet.

ALL COMMUNICATIONS SHOULD BE ADDRESSED TO  
BENTLEY MOTORS (1931) LTD., SERVICE STATION, HYTHE ROAD, WILLESDEN, LONDON, N.W.10

# Bulletin

MODEL BENTLEY MARK VI

- 2 -

When the button is released, the diaphragm is returned under spring pressure, and causes two jets of fluid to be directed on to the windscreen at a pre-determined point within each wiper arc. The screen wipers should then be set into operation, when the screen will immediately be cleaned.

The general arrangement of the system when installed in a right-hand drive car is shown in the illustrations above, and a list of material required will be found appended at the end of this leaflet.

### FITTING PROCEDURE.

1. Drill the dashboard for the storage jar mounting and rubber tubing grommets in accordance with either Fig. 2 or Fig. 3.

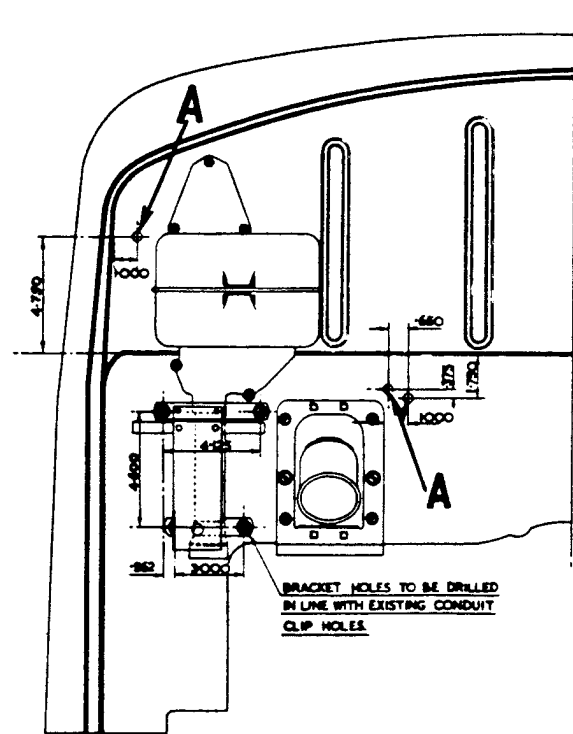
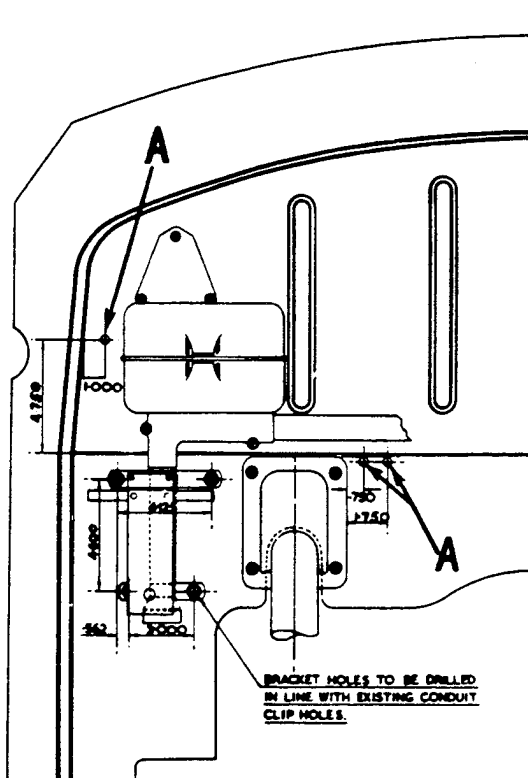

FIG. 2. DRILLING FOR EARLY TYPE DASH.  
(One-shot tank on L/H side)

FIG. 3. DRILLING FOR LATE TYPE DASH.  
(One-shot tank on R/H side)

- NOTES:**
- (a) Fig. 2 covers the drilling for ALL chassis prior to B-251-EW also certain chassis between B-251-EW and B-271-EW incl.
  - (b) Fig. 3 covers the remaining chassis up to B-273-EW and ALL chassis from B-273-EW inclusive.
  - (c) The three grommet holes marked 'A' to be 0.375" dia.
  - (d) The four bracket holes to be 0.250" dia.

ALL COMMUNICATIONS SHOULD BE ADDRESSED TO  
BENTLEY MOTORS (1931) LTD., SERVICE STATION, HYTHE ROAD, WILLESDEN, LONDON, N.W.10

# Bulletin

MODEL: BENTLEY MARK VI

- 3 -

2. Fit the mounting brackets to the storage jar cradle, using the three 2-BA bolts, nuts and spring washers supplied.

**NOTE:** Due to alteration in the dash layout on the later model chassis, two types of mounting brackets are employed as shown in Fig.4, the upper pair being for use on those chassis fitted with the early type dash (Fig.2), and the lower pair on the later type dash (Fig.3). Where the late type brackets (RD-5912/3) are used, the right-angled bracket arm should be fitted AWAY from the engine.

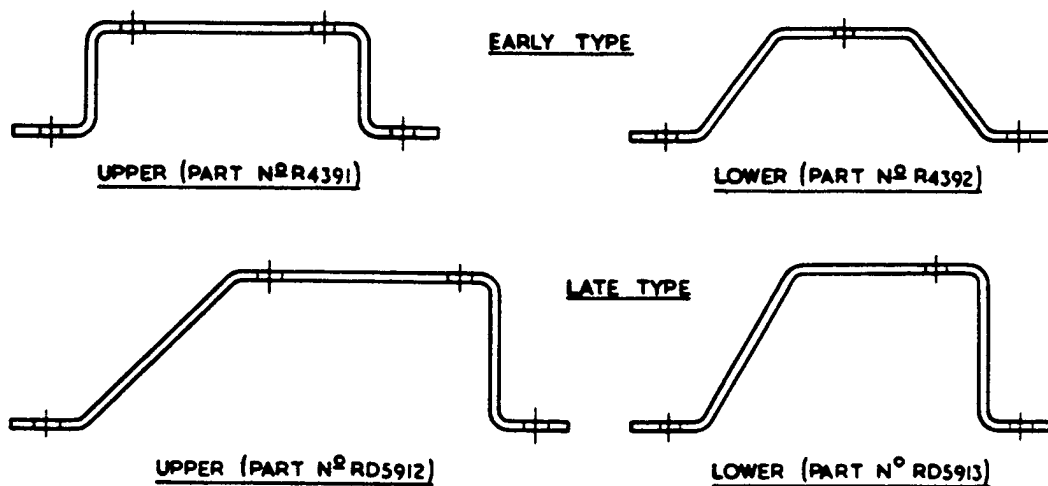

FIG. 4. MOUNTING BRACKETS.

3. Bolt the cradle assembly on to the dash and fit the storage jar as shown in Fig.1. (N.B. Sufficient clearance should be allowed between the pump diaphragm at the top of the jar and the fuse box cover to permit the subsequent removal of the cover without having to remove the jar).
4. Fit the suction pipe adaptor to the induction manifold:-
- a) Left-hand drive cars:- Drill and tap the induction manifold and fit the special adaptor (R-4356) as shown in Fig.5.

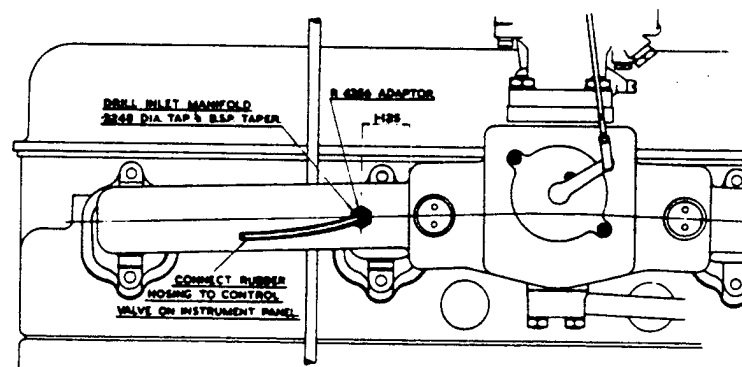

FIG.5. DRILLING OF MANIFOLD (LEFT-HAND DRIVE CARS).

# Bulletin

MODEL BENTLEY MARK VI

- 4 -

## b) Right-hand drive cars:-

- (i) Remove the air silencer (and oil bath if fitted,) and then the existing core plug at the forward end of the induction manifold.
- (ii) Fit the special adaptor, RE-10883, (Aluminium Washer KB-1081), and connect up the suction pipe (this should run BELOW the induction manifold). Fit the two suction pipe clips (RE-10852) to the outer studs of the front and rear "hot spot" flange connections as shown in Fig.10.
- (iii) Refit the air silencer (and oil bath if fitted).

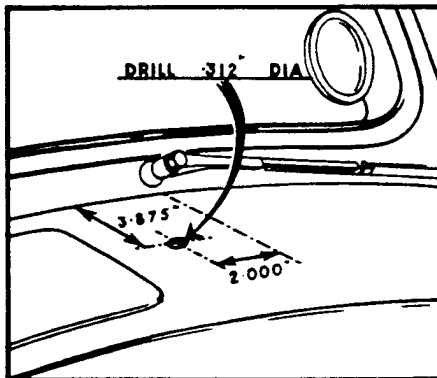

FIG. 6.

## 5. Drill the scuttle as shown in Fig.6:-

**NOTE:** Prior to drilling, remove the following items:-

- a) RADIO SET: Disconnect the aerial and power feed, (and bonding tape, if used) and remove the fixing screws.
- b) RADIO MOUNTING TRAY: Remove the six retaining setscrews, three countersunk headed on the left-hand side, and three cheesehead on the right-hand side.
- c) Withdraw the tool tray.

To ensure concentricity between the holes in the underskin of the scuttle and those in the top panel, it is recommended that the operator drills both panels in one operation.)

- d) Open out the two 0.312" dia. holes in the underskin to 0.7187" dia. and fit the two rubber grommets (D-74723) supplied.

## 6. Fit the two spray units as shown in Fig.7:-

**NOTE:** To obviate the possibility of a leakage, it is recommended that the threads at the spray unit end of the adaptors are treated with sealing compound.

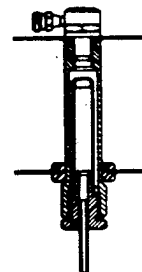

FIG. 7.

# Bulletin

MODEL BENTLEY MARK VI

- 5 -



A fine mesh filter is embodied in each adaptor body as shown, thus ensuring that no foreign matter which may be present in the pipe line can reach the spray jets at the end of the nozzle arms. These filters are easily removable for cleaning purposes, being integral with the brass hexagonal union nuts which screw into the bottom of the adaptors, (Fig.8 illustrates a filter assembly removed from its adaptor,) but care should be taken to prevent any slackening of the adaptor by holding a second spanner on the hexagonal portion of the adaptor body.

FIG.8.

7. Fit the press button control on the bottom right-hand corner of the fascia board as shown in Fig.9. (N.B. On left-hand drive cars, the press button control is fitted on the bottom left-hand corner, using the special mounting bracket, R-4320).

- a) Remove the existing angle bracket screws from behind the fascia board.
- b) Assemble the control button and mounting bracket together, and slide the top of the bracket between the back of the fascia and angle bracket.

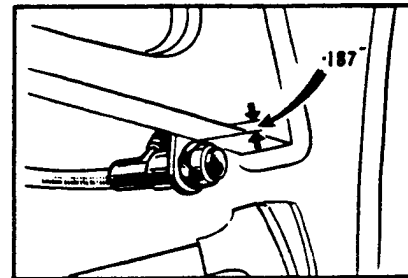

FIG. 9.

- c) Adjust the height of the mounting bracket to give approximately  $3/16$ " clearance between the bottom edge of the fascia and the hexagonal lock nut as shown, then, using the angle bracket as a template, mark off the relative positions for the two fixing holes in the blank flange of the mounting bracket. Withdraw the assembly and drill accordingly.
  - d) Refit the assembly and secure both the brackets together with the two longer wood screws supplied. (N.B. Normally the two longer screws will be sufficient to ensure that there is no movement in the mounting, but should greater rigidity in the bracket fixing be required, then use one of the original angle bracket screws for the top of the mounting bracket).
8. Install the various lengths of rubber tubing (Fig.10 refers to right-hand drive cars, and Fig.11 to left-hand drive cars:-)

- NOTES:**
- (a) The rubber tubing is supplied in two bulk lengths of 12'0" and 2'0", and will require cutting to suit the individual car.
  - (b) To avoid kinks forming in the tubing after it has passed through the dash and sepak, it is recommended that the holes drilled through the sepak are suitably radiused off on the DRIVER'S side.

9. Connect up the spray units and control button with the storage jar and suction pipe as shown.

# Bulletin

MODEL BENTLEY MARK VI

- 6 -

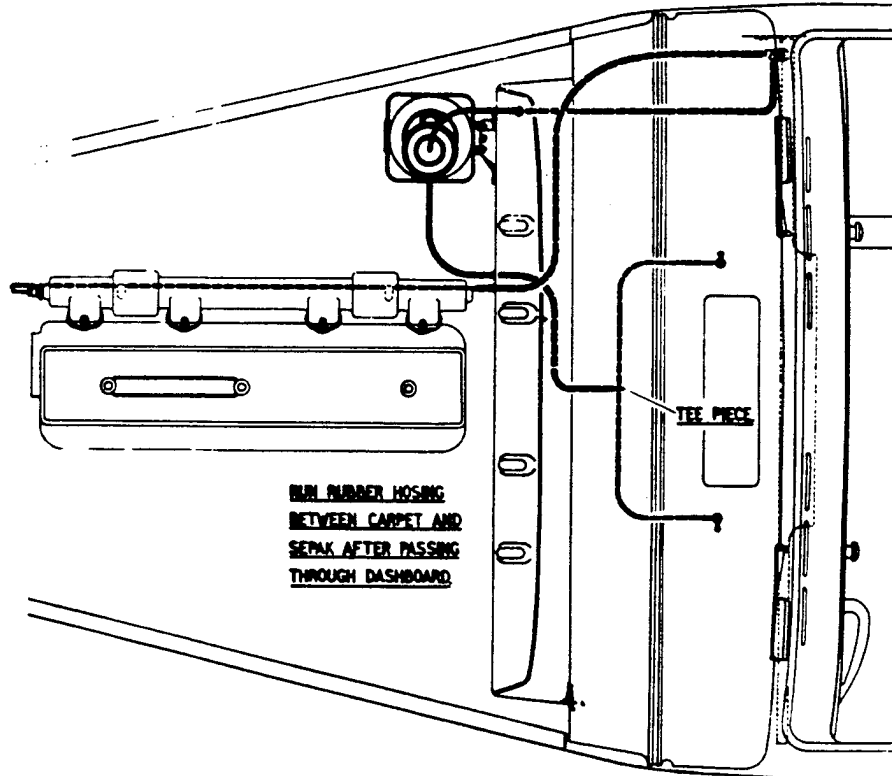

FIG. 10.

**NOTE:** The run of  $3/16$ " I/D tubing from the top adaptor of the pump diaphragm goes to the control button, while that from the lower adaptor is connected to the tee-piece of the spray unit pipe line below the scuttle.

10. Fill up the storage jar with clean water, start up the engine, and test for correct functioning of the system.

A certain amount of adjustment will be necessary to ensure that the two jets of water impinge on to the windscreen both centrally and at approximately 1.00" BELOW the highest point of each wiper arc, Fig.12.

The first essential will be obtained by initially fitting the spray units with their nozzle arms set FORWARD approximately  $12\frac{1}{2}^\circ$  relative to the lower beading of the windscreen.

The second requirement, i.e. correct jet elevation, will necessitate the nozzle arm being either further tightened up or slackened back in the spray unit body. Of these, the former method is preferable, but should it be found necessary to slacken the arm back, it is recommended that the threads of the nozzle arm are treated with a suitable sealing compound to obviate the possibility of a leakage developing during service.

# Bulletin

MODEL BENTLEY MARK VI

- 7 -

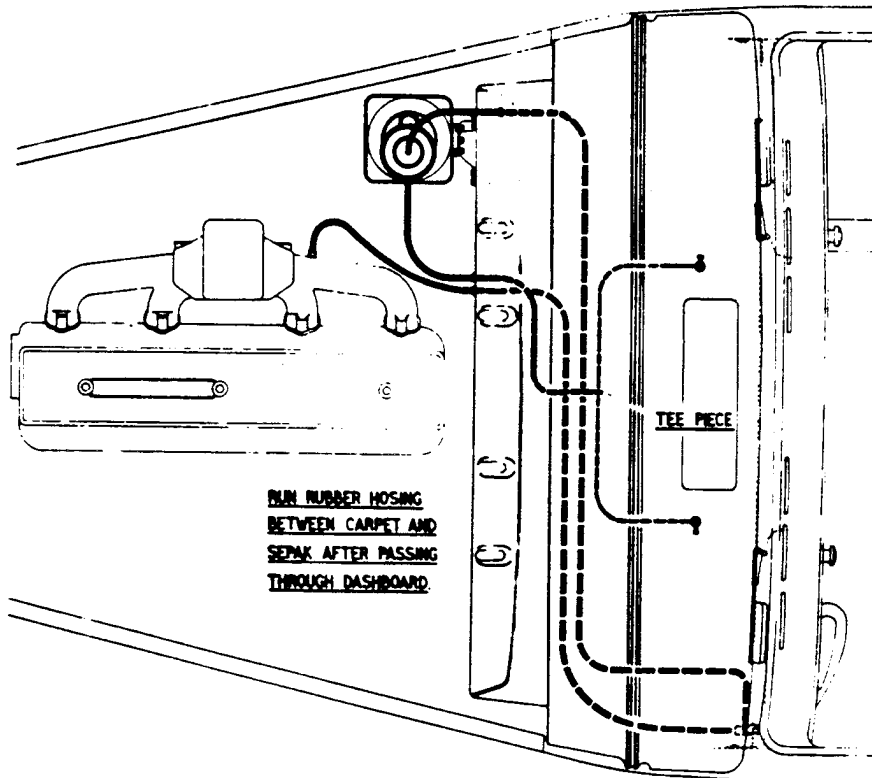

FIG. 11.

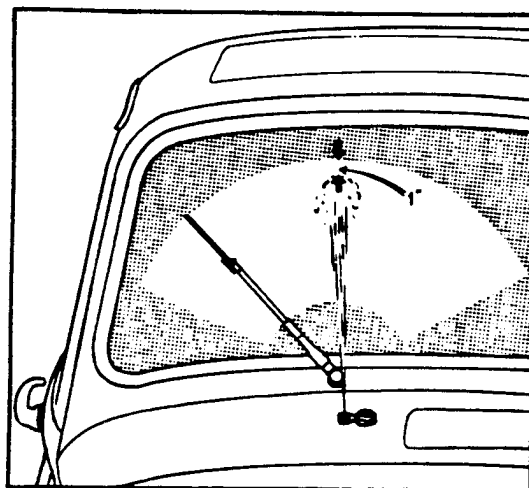

FIG. 12.

ALL COMMUNICATIONS SHOULD BE ADDRESSED TO  
BENTLEY MOTORS (UK) LTD SERVICE STATION, 14 THE ROAD, WILLSDEN, LONDON, W.11

**Bulletin**

MODEL BENTLEY MARK VI

- 8 -

LIST OF PARTS REQUIRED.

RD-5947	TRICO FOLBERTH STANDARD KIT.	1 off
	Comprising the following:-	
R-4139	Glass Container	1 "
R-4140	Support Bracket - Glass Container	1 "
R-4104	Diffusion Chamber	1 "
R-4145	Lid - Glass Container	1 "
R-4167	Suction Pipe & Filter - Glass Container	1 "
R-4120	Control Button Valve	1 "
R-4121	Tee-Piece - Spray Unit Pipe Line.	1 "
R-4113	Spray Unit Assembly	2 "
R-4520	Rubber Washer - Spray Unit to Scuttle	2 "
	The following to be ordered separately as <u>NOT</u> in standard Kit:-	
xR-4356	Adaptor - Induction Manifold	1 "
+R-10883	Adaptor - Induction Manifold	1 "
+KB-1081	Aluminium Washer - Induction Manifold Adaptor	1 "
+K-3001	Compression Sleeve - for above	1 "
+KB-3021	Nut - Suction Pipe to Manifold Adaptor	1 "
+RE-10851	Suction Pipe - Induction Manifold to Dash	1 "
+RE-10852	Clip - Suction Pipe to Induction Manifold	2 "
RF-5032	Grommet - Rubber Tubing through Dash	3 "
RD-6287	Adaptor - Spray Unit Mounting	2 "
RD-6286	Filter Assembly - for above	2 "
RD-6290	Rubber Washer - Filter Union to Adaptor	2 "
KB-1078	Washer - Adaptor to Spray Unit	2 "
D-74723	Grommet - Spray Unit Adaptor through Underskin	2 "

ALL COMMUNICATIONS SHOULD BE ADDRESSED TO  
BENTLEY MOTORS (UK) LTD. SERVICE STATION, MYTHE ROAD, WILLESDEN, LONDON, N.W.10

SB/GF 1/SF 23.2.51.

SECTION U



MODEL: BENTLEY MARK VI

- 9 -

R-4391	Mounting Bracket-Upper-Storage Jar Cradle to Dash.	1	Off
R-4392	do. -Lower- do.	1	"
<sup>1</sup> RD-5912	do. -Upper- do.	1	"
<sup>1</sup> RD-5913	do. -Lower- do.	1	"
K-203/Z	Bolt, Retaining-Mounting Bracket to Dash.	4	"
K-4310/z	Nut - for above.	4	"
K-9008/Z	Spring Washer - for above.	4	"
K-1910/Z	Screw, Retaining-Cradle to Mounting Bracket.	3	"
K-4307/Z	Nut - for above.	3	"
K-9006/Z	Spring Washer - for above.	3	"
+R-4146	Mounting Bracket-Control Valve to Facia.	1	"
xR-4320	do. do.	1	"
CS-31345	No.4 Wood Screw x 5/8" long - for above.	2	"
RD-5510/11/16.	Rubber Tubing - Main Pipe Line-0.156"x0.343" o/d	12	Ft.
RD-5512/3.	Rubber Tubing-Spray Unit Pipe Line-0.109"x0.235"	2	"

NOTES: (a) Items marked with x refer to left-hand drive cars ONLY.

(b) Items marked with + refer to right-hand cars ONLY.

(c) Items marked with <sup>1</sup> refer to chassis fitted with the late type dash, i.e. ALL chassis between B-273-EW and B-500-FV incl.

ALL COMMUNICATIONS SHOULD BE ADDRESSED TO

BENTLEY MOTORS (1951) LTD. SERVICE STATION, HYTHE ROAD, WILLESDEN, LONDON, N.W.10

FOR INFORMATION:

PETROL FILLER DOOR LOCKS.

Retailers are advised that petrol filler door locks are now available for fitting to Bentley Standard Saloons already in service at an extra charge.

Fig. 1 illustrates the finished appearance of a petrol filler door with a lock fitted.

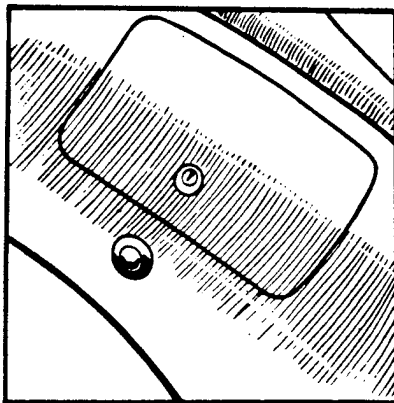

FIG. 1.

FITTING INSTRUCTIONS.

1. Remove the filler door from the wing.
2. Remove the existing filler door striker plate.
3. Mark off the datum line "AA" as shown in Fig. 2.
4. Mark off and then cut away the inner panel of the door as shown in Fig. 2.
5. Drill the outer panel of the door as shown in Fig. 2.

NOTE: Particular care should be taken when drilling this hole, as any appreciable error will result in difficulty being experienced with the operation of the door lock when it is finally assembled.

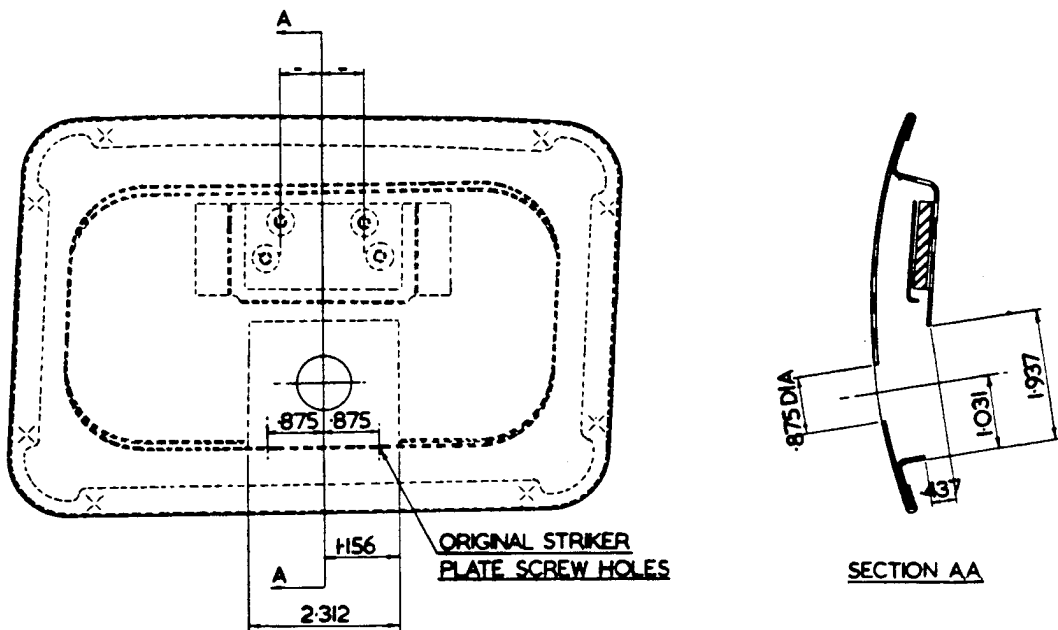

FIG. 2.

ALL COMMUNICATIONS SHOULD BE ADDRESSED TO  
BENTLEY MOTORS (1931) LTD., SERVICE STATION, MYTHE ROAD, WILLESDEN, LONDON, N.W.11

# Bulletin

MODEL: BENTLEY MARK VI

- 2 -

6. Weld the rear lock striker plate to the back of the lock mounting plate, ensuring that this is set  $1/16"$  (1.6 mm) inwards from the bottom edge of the mounting plate as shown in dimension "A" Fig. 3.
7. Rivet the lock assembly to the front of the mounting plate, using the four rivets provided.

**NOTE:** Prior to riveting, it is recommended that the slot cut in the mounting plate is checked for clearance in conjunction with the tongue of the lock.

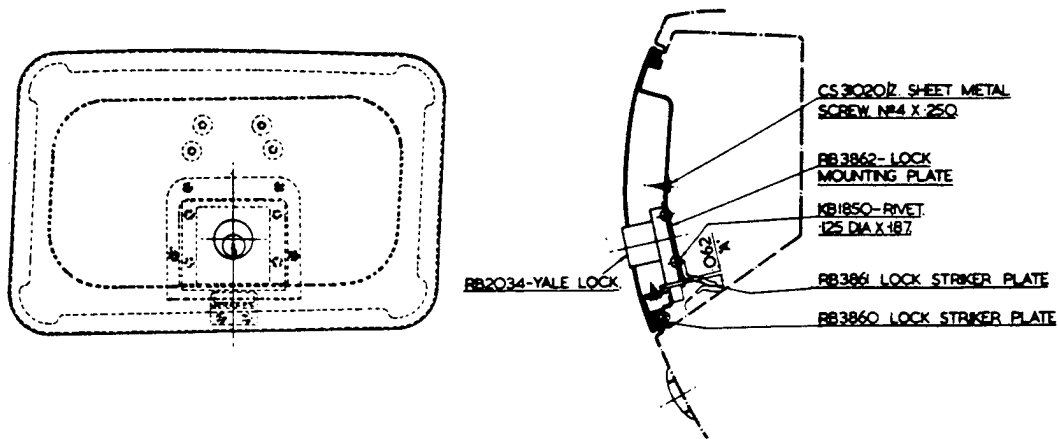

FIG. 3.

8. Temporarily locate the lock in position in the filler door and mark off the centres for the six retaining screws, using the mounting plate as a template.
9. Remove the lock assembly and drill the inner door panel accordingly. Refit the lock assembly and secure to the door panel by means of the retaining screws as shown in Fig. 3.
10. Drill and secure the front striker plate to the interior flange of the filler compartment as shown in Fig. 3, using two 3-BA countersunk headed screws and nuts. Replace the rubber grommet after tightening the nuts.
11. Refit the filler door to the wing.

A certain amount of adjustment may be necessary before satisfactory operation between the door lock rear striker plate and the existing push button catch is obtained. As this entails bending the striker plate, either upwards or downwards, care should be taken to ensure that, when closing the door, this clears the front striker plate.

ALL COMMUNICATIONS SHOULD BE ADDRESSED TO  
BENTLEY MOTORS (1931) LTD. SERVICE STATION, HYTHE ROAD, WILLESDEN, LONDON, N.W.10

SECTION

**Bulletin**

MODEL : BENTLEY MARK VI

Cancel Page 3 of Bulletin BB-69  
dated 13.4.49.

- 3 -

MATERIALS REQUIRED.

RB.2034	Lock Assembly, Yale	1 off.
RB.3862	Lock Mounting Plate	1 off.
RB.3861	Rear Striker Plate	1 off.
RB.3860	Front Striker Plate	1 off.
KB.1850	Rivet	4 off.
CS.31020/Z	Screws, Sheet Metal No.4.	6 off.

All the above are obtainable from the London Service Station.

**Bulletin**

MODEL : BENTLEY MARK VI

**CATEGORY 1 MODIFICATION:****REAR NUMBER PLATE ILLUMINATION.**

In order that all Bentley Mark VI cars now operating in the U.S.A. shall conform with existing lighting regulations, a modified type of rear number plate support bracket has been introduced, which, when used in conjunction with the existing lamp, will provide direct illumination of the rear number plate.

This modified support bracket differs from the standard fitting by having a built-up boss, the outer face of which is set at an angle of  $28^{\circ}$  relative to the bracket itself. The lamp is fixed to this inclined face, thus ensuring that the number plate is directly lit.

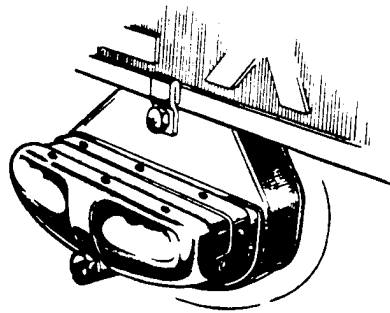

PRE-MODIFIED ASSEMBLY.

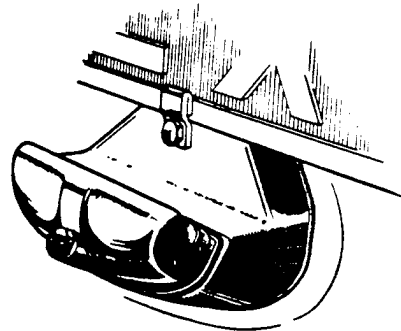

MODIFIED ASSEMBLY.

Arrangements have been made for the despatch of sufficient quantities of these modified brackets to cover all known requirements, and Retailers are requested to effect this modification as soon as cars are available. Further supplies of these modified brackets, if necessary may be obtained upon application to the London Service Station, Hythe Road, Willesden, London.N.W.10.

**FITTING INSTRUCTIONS.****A. REMOVAL AND DISMANTLING OF EXISTING BRACKET AND LAMP ASSEMBLY:**

1. Remove the spare wheel lid from the body, first ensuring that all light cables are disconnected at the junction box end.
2. Lay the spare wheel lid on the bench and remove the 27 small set screws which secure the inner cover plate to the inside panel of the lid. Remove the cover plate.
3. Remove the 3 x 1/4" B.S.F. nuts securing the rear number plate support bracket to the lid. The spare wheel lid and support bracket may now be separated, but care should be taken to see that neither the metal plate nor the rubber seal interposed between the bracket and outer surface of the lid are lost or damaged, as these will be required again.
4. Remove the acorn nut and clamping stud securing the rear number plate carrier to the support bracket, and also the small set stud and clamping piece located at the base of the number plate itself.

ALL COMMUNICATIONS SHOULD BE ADDRESSED TO  
BENTLEY MOTORS (1931) LTD., SERVICE STATION, HYTHE ROAD, WILLESDEN, LONDON, N.W.10

**Bulletin**

MODEL BENTLEY MARK VI

- 2 -

5. Extract the three 1/4" x 7/8" B.S.F. studs from the back face at the base of the support bracket. Remove the lamp assembly. (The support bracket casting may now be discarded).

**B. FITTING OF THE MODIFIED SUPPORT BRACKET AND LAMP:**

1. Fit the three 1/4" x 7/8" B.S.F. studs to the back face of the modified support bracket.
2. Fit the existing number plate and carrier, using the original acorn nut and clamping stud. Secure the base of the number plate by means of the small set stud and clamping piece.
3. Fix the lamp to the inclined face of the boss at the base of the support bracket.
4. Fit the complete assembly to the spare wheel lid, ensuring that the metal plate and rubber seal are correctly interposed.
5. Thread the light cables through the inner cover plate and secure the plate to the inside panel of the spare wheel lid by the 27 small set screws.
6. Refit the spare wheel lid to the body and connect up the light cables. (With the new lamp bracket, only one bulb is necessary).

It should be noted that all modified support brackets will require painting at the time of assembly to suit individual requirements.

MODIFICATION

FOR INFORMATION AND ACTION IF NECESSARY

TOP SCUTTLE VENTILATOR  
(Standard Steel Saloon Body)

In the event of a complaint from a customer of insufficient ventilation through the top scuttle ventilator, a modification has been introduced as described below for improving the air flow, by removing the existing two grilles from the scuttle ventilator lid and fitting a nickle plated wire mesh screen. (Part No. RB.5266 - obtainable from the London Service Station.)

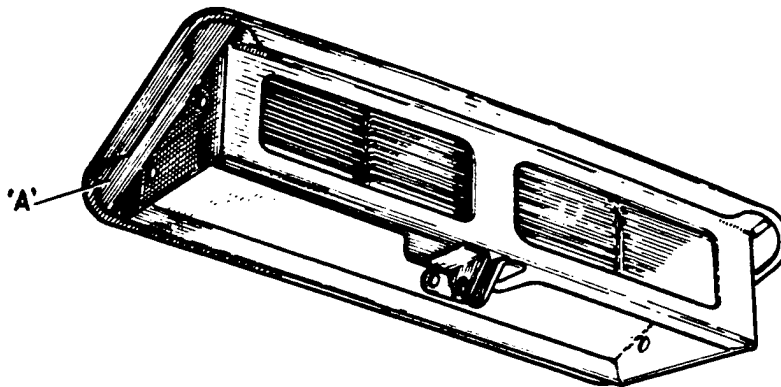

Fig. 1.

To fit proceed as follows:-

- (i) Remove the scuttle ventilator lid by unscrewing two screws on each end and removing the pin or bolt from the lower end of the link attached to the lid.
- (ii) Remove the two grilles, (shown in Fig.1) starting from the outer ends by drilling into the spot welds on the inside. The inner ends can then be easily removed with a small chisel.
- (iii) With a pair of shears or a hack-saw open out the two intake holes and file to the dimensions shown in Fig. 2. leaving the double thickness of metal down the central division.
- (iv) Solder the wire mesh screen in position so that it covers the whole of the inside face of the intakes.

Note: If upon examination of the sealing surface of the underside of the lid it is found there is a depression at each of the four corners, ('A' Fig.1), caused by the clinched-over flange, then opportunity should be taken to fill them in as described below, in order to make the surface smooth and flat, thus making a better water seal.

The lids of a number of cars in service have already been attended to in this respect.

-2-

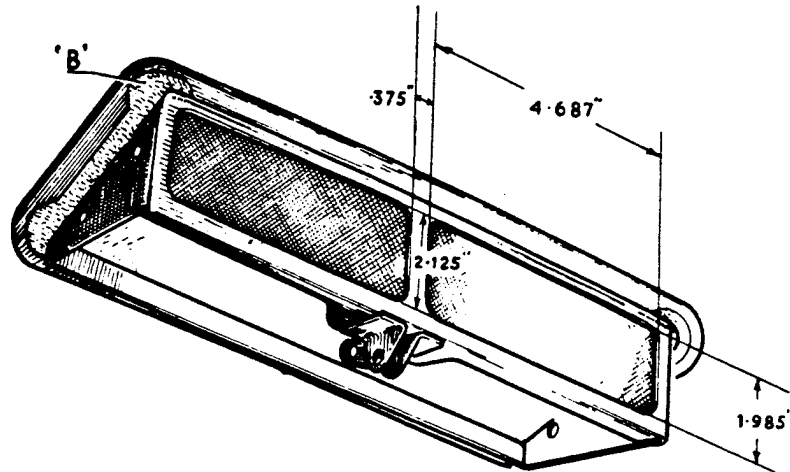

Fig. 2.

- (a) Thoroughly clean the underside of the lid and fill in the depression at each corner with solder to surface level, ('B', Fig. 2). Also fill in the channel running along the two sides, which lead into each corner. Face off the solder as necessary until it is flush all the way round.
- (b) Mask the wire screen and re-cellulose the lid taking care to match the colour. Do NOT cellulose the wire screen.  
Note: The above method of filling-in, which is preferable to the method described below, should however, only be undertaken where it is possible to match the existing colour, because, owing to the blistering effect of the solder it will be necessary to entirely re-cellulose the lid.

If the existing colour cannot be matched then proceed as follows:-

- (a) Fill in the depression at each corner with plastic wood to surface level. Also fill in the channels running along the sides and front leading into the depressions. A similar channel at the rear of the lid need only be filled in to about one inch from either end. Allow the plastic wood to dry.
- (b) Smooth the plastic wood surface with medium grade sandpaper and apply a layer of cellulose stopping to the plastic wood.
- (c) Mask the wire screen and re-cellulose the lid as necessary.

Should it be found that the rubber seal is not in a good condition, then opportunity should also be taken to fit a new one. (Part No. RB.4825 - obtainable from the London Service Station.)

The fitting of a new rubber seal is fully described in Service Bulletin No. EB-34 (Section U).

If a new seal is fitted, it is important that the Bostik adhesive should be allowed to thoroughly dry before closing the lid, otherwise, the seal will take an incorrect set.

- (vi) Replace the ventilator lid, making sure that the clearance between the lid and

**Bulletin**

MODEL: BENTLEY MARK VI

-3-

the body aperture is consistent all round, and that the lid is flush with the scuttle top in the closed position.

Will all Retailers please notify this Service Station of the chassis numbers of cars on which this work is carried out.

FOR INFORMATION.FRONT WINDOW RATTLE.

Cases have occurred in service where vibration has caused the front windows on early type Bentley Standard Saloons to rattle when these are in the half open position.

Normally, the "U" shaped rubber sealing strip fitted to the front of the window frame acts as a buffer between the projecting lip of the frame and the rear edge of the ventilator glass. Constant usage during service, however, tends to distort this seal, with the result that direct contact is established, thus rendering it liable for window rattle to develop.

As a means of obviating this a special rubber buffer strip (Part No. R-4343) has been introduced, and Retailers are recommended to incorporate this whenever dealing with complaints of this nature.

This will involve the cutting away of approximately 1.00" of the existing seal to accommodate the rubber buffer at the topmost corner of the window frame as shown in the sketch below.

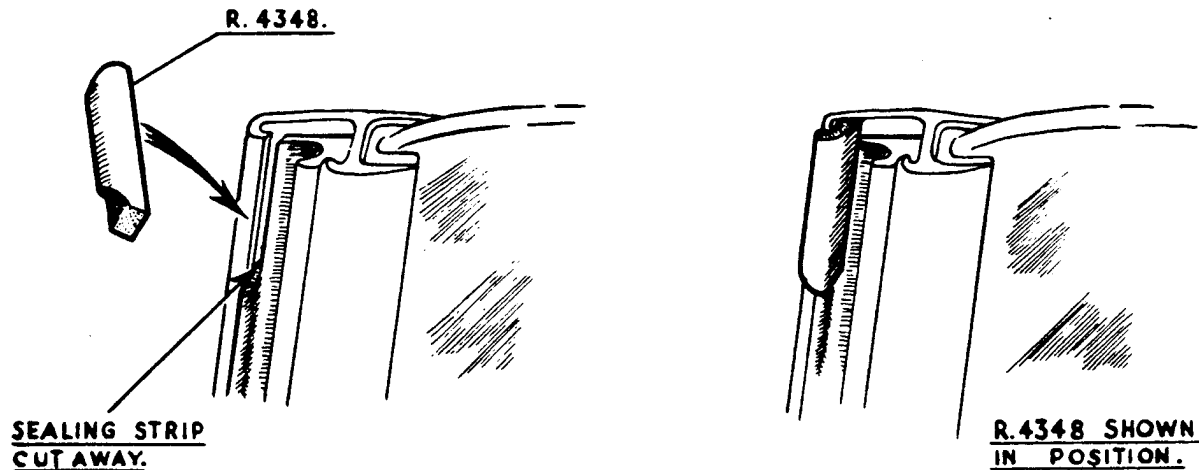

A suitable sealing compound for retaining this buffer strip in position is Bostik No. 252.

**Bulletin**

MODEL BENTLEY MARK VI

FOR INFORMATIONCARE AND MAINTENANCE OF LEATHER UPHOLSTERY

Retailers are advised, that in the majority of cases, deterioration in the general appearance of the leather upholstery, apart from normal wear and tear during service, is due to grime or dirt becoming ingrained in the surface of the leather.

In view of this, it is thought advisable to issue the following recommended procedure for the care and maintenance of the leather upholstery so that Retailers may effectively deal with complaints of this nature.

- (1) Dissolve a sufficient quantity of good quality soap flakes to ensure a good lather, and then thoroughly wash the leather, using a soft cloth for the purpose. DO NOT scrub with a hard brush.
- (2) Swab off with clean water and thoroughly dry the leather.
- (3) Treat the leather with Connolly's Hide Food as follows:-
  - a) Apply evenly with a soft cloth, changing the surface of the cloth frequently.
  - b) Polish with a soft DRY cloth.

**Bulletin**

MODEL BENTLEY MARK VI

FOR INFORMATION.LUBRICATION OF DOOR HINGES.

Certain cases have arisen where the car door hinges have become rough or stiff after a period of service, which has shown to have been due to inefficient lubrication.

It is realised that the effective lubrication of the top slide, where roughness occurs due to the tilting action of the hinges under the weight of the door, presents some difficulty, as the lubricant is likely to be scraped off by the sliding action of the moving parts.

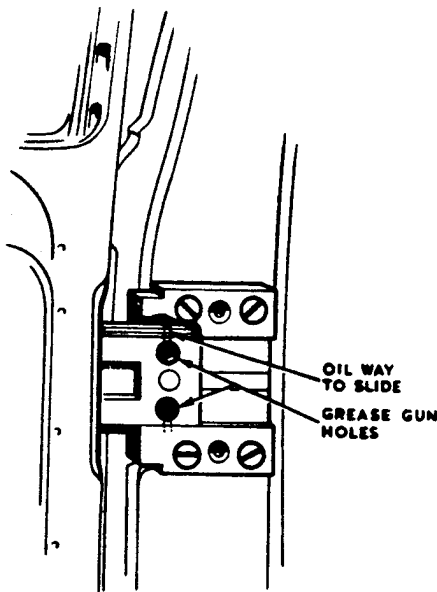

It has therefore been decided that on the original build up of the car at the Factory, that the door hinges are to be lubricated with a graphited grease, namely D.A.G. graphite grease "G.A", and Retailers are recommended that if a door is being overhauled in service, that they should also carry out similar action.

A modification is to be introduced by the drilling of two suitable holes in the slide piece for the insertion of the grease gun, (see illustration) and it will be recommended in the Owner's Handbook that this part is periodically serviced, every 10,000 miles by the Owner, using Mobilgrease No. 2 as the grease gun in the car tool kit is already charged with this grease.

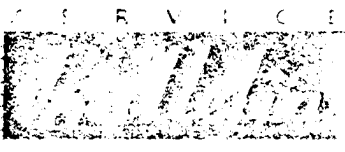

BENTLEY MARK VI

FOR INFORMATION:

MODIFICATION TO QUICK-LIFT WINDOW REGULATOR.

A few instances have been reported where the quick-lift window regulator handle has worked loose during service on existing models of Bentley Mark VI Standard Saloon.

As a means of overcoming this, a tapered plug (Part No.R-4457) has been introduced for fitting into the end of the existing splined shaft of the window regulator, and Retailers are recommended to incorporate this whenever dealing with complaints of this nature.

This will involve the slotting and counterboring of the splined shaft to accommodate the tapered plug, and all the necessary instructions for fitting are given below.

Fig. 1 illustrates the general arrangement of the regulator assembly with the plug in position.

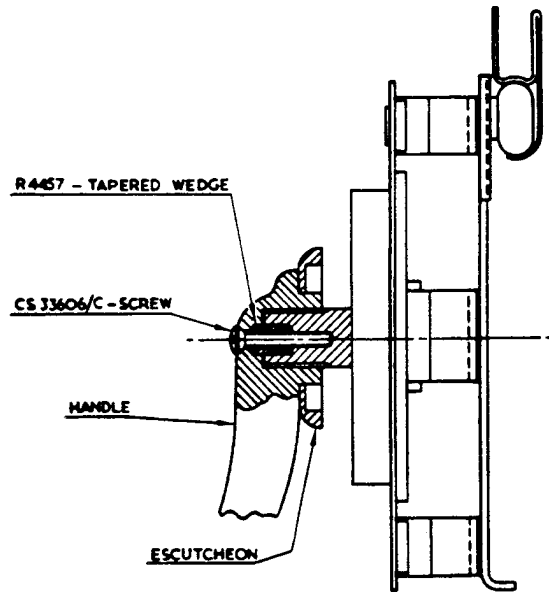

FIG. 1.

FITTING INSTRUCTIONS.

1. Turn the regulator handle to either the fully closed or fully open position.
2. Remove the countersunk-headed setscrew securing the handle to the splined shaft, and then pull off the handle. (N.B. The handle is splined on to the shaft, and it is therefore recommended that its original setting relative to the shaft is suitably noted to ensure identical re-assembly).
3. Fit a sheet of stiff paper or cardboard over the splined shaft as a means of protecting the interior trim of the door against possible damage.

- 2 -

4. Using a hacksaw blade with as narrow a "kerf" as possible, make a vertical cut longitudinally through the shaft to a depth of 0.500" as shown in Fig. 2. Cut a similar slot at right angles to the first cut, and then prise the four segments open to ensure a tight fit between the handle and the splined shaft. (N.B. It is emphasized that this opening out is effected prior to counter-boring the shaft.)
5. Counterbore the end of the splined shaft 0.297" dia. and to a depth of 0.312" as shown in Fig. 2, and then file down the remains of the original boss flush with the face of the shaft.

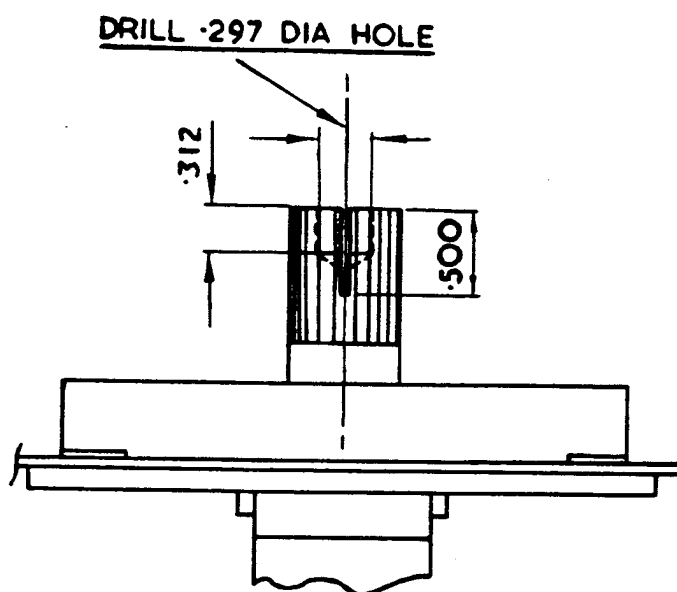

FIG. 2.

6. Fit the tapered plug into the counterbore, pushing this in as far as it will go with the fingers only. Reposition the handle on the shaft in its original relative position and tap fully home, using a rawhide mallet for the purpose. Fit the longer setscrew (CS.33606/C) supplied, and fully tighten this up.

NOTE:- Should the tapered plug be too long and prevent the handle from nipping the escutcheon plate against the door trim, then it should be suitably shortened.

MATERIAL REQUIRED.

B-4457	Tapered Plug.	1 Off.
CS-33606/C	Setscrew, retaining - Handle to Shaft.	1 Off.

**Bulletin**

MODEL BENTLEY MARK VI

FOR INFORMATION:WEIGHTS & DIMENSIONS OF COACHBUILT & STANDARDSTEEL BODIES

The overall length of the car will vary according to the bumpers fitted, and the figures included in this table for that dimension have been based on the assumption that Wilmot-Breeden bumpers are fitted. In cases where cars are intended for export, bumpers may vary considerably, thus affecting the overall length of the cars.

COACHBUILDER & TYPE OF BODY.	LENGTH.	WIDTH.	HEIGHT.	WEIGHT.(approx.)	
				Tons.	Cwt
Bentley Motors (1931) Ltd. 4 door standard steel sports saloon.	16'0"	5'11"	5'6"	1	17
Park Ward & Co Ltd. drophead foursome coupe.	17'2"	6'0"	5'4"	1	19
Park Ward & Sons Ltd. 2 door sports saloon.	17'2"	6'0"	5'4"	1	19
H.J.Mulliner & Co Ltd. 4 door sports saloon.	17'0"	6'0"	5'3"	1	17
James Young Ltd. 2 door sports saloon.	16'10"	6'0"	5'8"	1	18
James Young Ltd. 4 door sports saloon.	16'10"	6'0"	5'8"	1	18
Hooper & Co.Ltd. 4 door saloon.	16'10"	6'0"	5'5"	1	18
E.D.Abbott Ltd. 2 door drophead coupe.	16'10"	5'9"	5'6"	1	18

# Bulletin

MODEL: BENTLEY MARK VI

FOR INFORMATION:REVISED METHOD OF FITTING WINDSCREEN GLASS - STANDARD STEEL SALOON.

The attention of Retailers is drawn to the following amendments in the existing instructions covering the fitting of a replacement windscreen glass in service (Section U, Sub-Section BU-3, Bentley Workshop Manual.)

A. "REMOVAL OF WINDSCREEN ASSEMBLY".

Remove the screen assembly as instructed, but DO NOT discard the existing rubber seal unless it has been damaged or shows signs of deterioration due to age.

B. "FITTING OF REPLACEMENT GLASS".

- (i ) Remove the old glass as instructed. (N.B. Where the original rubber seal is being used again, the inner edge of the seal should be rolled back to expose the heads of the twenty countersunk screws which secure the outer and inner frames together.)
- (ii ) Prepare the new glass, using ONLY the 1.00" wide strip of "Prestik" (See 5, Fig.15) and then fit the glass into the frame as instructed.

C. "REPLACING THE SCREEN ASSEMBLY".

DO NOT clean out the seal channel, but smear "Seelastik" over the original packing and shoulder of the recess, and then refit the screen assembly to the body as instructed.

NOTE: The original type seal, RB-2512, (Fig.1) has been replaced by the improved design, RB-4880, (Fig.2), which will be supplied in all cases where a new seal is required.

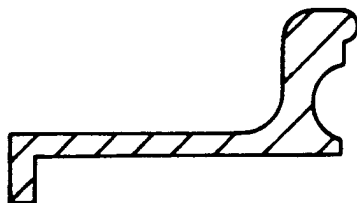

FIG. 1. ORIGINAL TYPE SEAL  
(OBSOLETE)

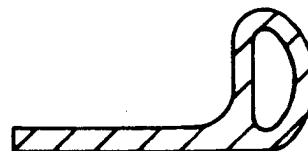

FIG. 2. CURRENT REPLACEMENT.

**Bulletin**

MODEL: BENTLEY MARK VI

INSTRUCTIONS FOR RENOVATING FINISH ON INTERIOR WOODWORK.STANDARD STEEL SALOON.

This Bulletin sets out the recommended procedure and materials for carrying out repairs to slight damage to the interior woodwork of cars.

It is stressed that repairs should be confined to superficial damage restricted to small areas; extensive repairs require that the final coats of synthetic resin woodfinish be subjected to stoving in a special oven under controlled conditions of temperature and humidity.

1. FINISH BLISTERED - FILM REMOVED DOWN TO BARE WOOD:

- a) Rub down with Grade 400 Durex Paper, apply one coat of wood primer, and when dry, apply woodfiller over surface, rub off and leave for at least 2 hours. (Preferably overnight)
- b) Apply another coat of wood primer, build up with sealer and then face smooth with Grade 400 Durex Paper.
- c) Obtain and apply the required shade to match existing colour by mixing burnt umber pigment and french polish.
- d) Apply one coat of N/C Glossy woodfinish.
- e) Flat with Grade 400 Durex Paper and apply a coat of either "glossy" or "satin" synthetic woodfinish as required. Leave to air-dry for 48 hours.
- f) Flat with Grade 500 Durex Paper and drop of Shell Oil A-12, or water containing  $\frac{1}{2}\%$  "Teepol" wetting agent.
- g) Finish with Rubbing compound and No.7 or A.1. polish, leaving out the latter for matt finish.

2. WOODWORK PITTED:

- a) Stop with Brummer stopper proud of holes. Leave for 2 hrs.
- b) Face with Grade Durex Paper, apply thin coat of sealer.
- c) Colour to match as in 1 (c).

For Glossy Finish:

- d) Apply N/C "glossy" woodfinish.
- e) Finish with rubbing compound and polish.

**Bulletin**

MODEL : BENTLEY MARK VI

- 2 -

For Matt Finish:

d) Apply another coat of sealer and face.

3. SHALLOW MARK OR SLIGHT DENT:

- a) Flat lightly with Grade 500 Durex Paper, coat with sealer to required face.
- b) Flat with Grade 400 Durex Paper, apply N/C "glossy" woodfinish and polish off, or leave in sealer for matt.

MATERIALS REQUIRED.

- 1 . RR-9507103 Light Woodfiller.  
RR-9507103D Dark Woodfiller.
- 2 . RR-9502109 Wood Primer.
- 3 . RR-9507911 Brummer Stopper.
- 4 . RR-9507122 Sealer.
- 5 . Burnt umber pigment.
- 6 . French Polish (2 ozs. genuine dry bleached lac (wax free) to  
1 pint of methylated spirits 66 O.P)
- 7 . Rk-L.2543 N/C Glossy Woodfinish.
- 8 . RR-L.2546 Synthetic Woodfinish (satin)
- 9 . RR-L.2545 Synthetic Woodfinish (glossy)
10. RR-L.2542 Accelerator (for use with 8 & 9).
11. RR-9503901 Shell Oil A-12.
12. Durex Paper Grades 400 and 500.
13. RR-9508102 Rubbing compound.
14. RR-9508101 No.7 Polish or RR-950807 A.1. Polish.
15. RR-L.2548 Thinners for Primer, Sealer and Glossy Woodfinish.
16. RR-L.2547 Thinners for Synthetic Woodfinish.

FOR INFORMATION:ADDITIONAL INTERIOR CAR HEATER

An additional interior heater is available to customers requirements, and may be fitted to either the Standard Steel Saloon or Coachbuilt bodies.

The heater is attached to the dashboard below and behind the radio set and diffuses warm air just above floor level.

Heat is supplied from the engine cooling system and an electric fan, integral with the heater is used for distribution.

For early chassis numbers, (B.2.AK. to B.191.DZ) the heater also includes an improved demister system and the heater itself is provided with a foot operated lid, so that interior heating can be cut off if demisting only is required; the electric fan is operated by a rheostat switch on the fascia board.

For later cars, the heater is fitted with an open front and control is also by rheostat.

Prices may be obtained from the London Service Station.

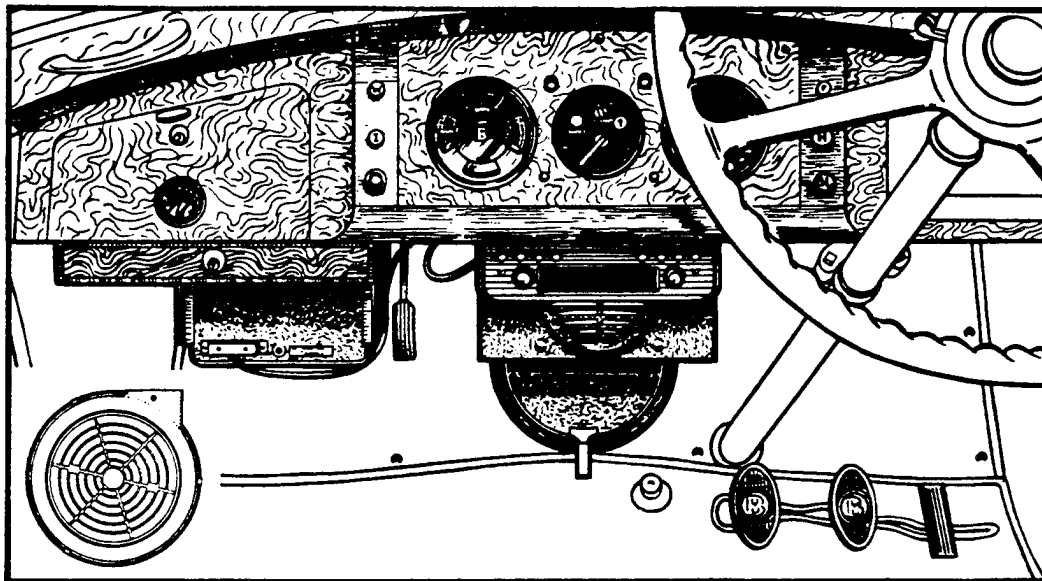

Fig. 1.

Fig. 1. illustrates the heater fitted when demisting is included. The inset shows the open front heater used when supplemented demisting is not required.

- 2 -

INSTALLATION INSTRUCTIONS

Fig. 2.

Fig. 2. shows the theoretical installation with the demister system shaded.

1. Remove the radio set.  
(On Chassis Nos. B.2.AK. - B.191.DZ, if improved demister is required, also remove the demister motor, air silencers, the heater element in the right-hand demister duct, the wiring to M & F switches and the earth wire from the back of the switchbox.)
2. Disconnect the speedometer trip control from the radio mounting tray and remove the tray.
3. Remove the dashboard carpet and lift the insulating material. Mark off and drill the dashboard in accordance with the following drawings (Figs. 3, 4, 5, 6 and 7) where applicable.
4. Cut a circular recess in the rearward face of the insulation 4.25" dia., by 0.300" deep concentric with the three heater fixing holes and pierce the remaining holes to correspond with those in the dashboard.
5. Cut the carpet to correspond with the recess and other holes in the insulation.

# Bulletin

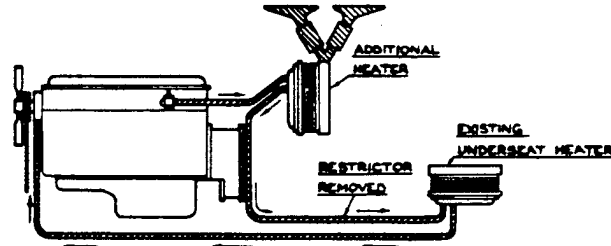
MODEL BENTLEY MARK VI

- 3 -

## DASHBOARD DRILLING

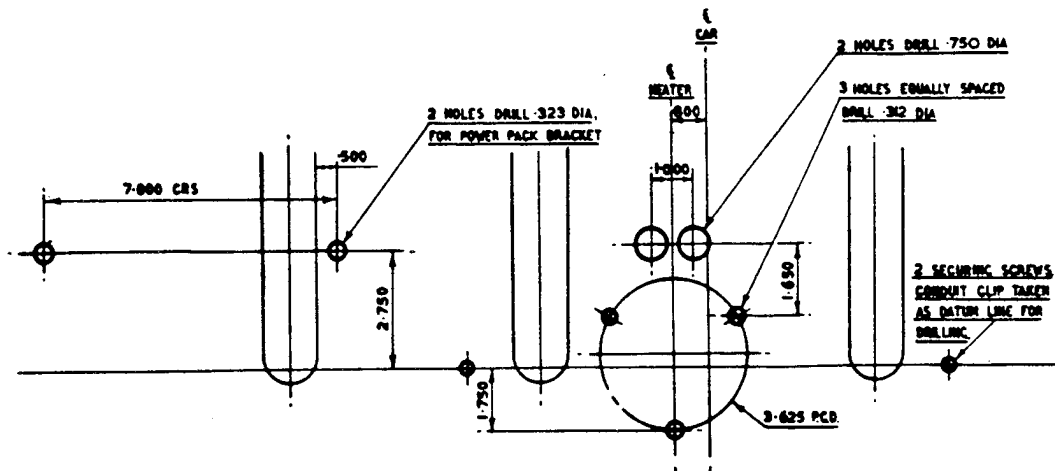

Fig. 3. CHASSIS NOS. B.2.AK - B.271.EW - RIGHT-HAND DRIVE.

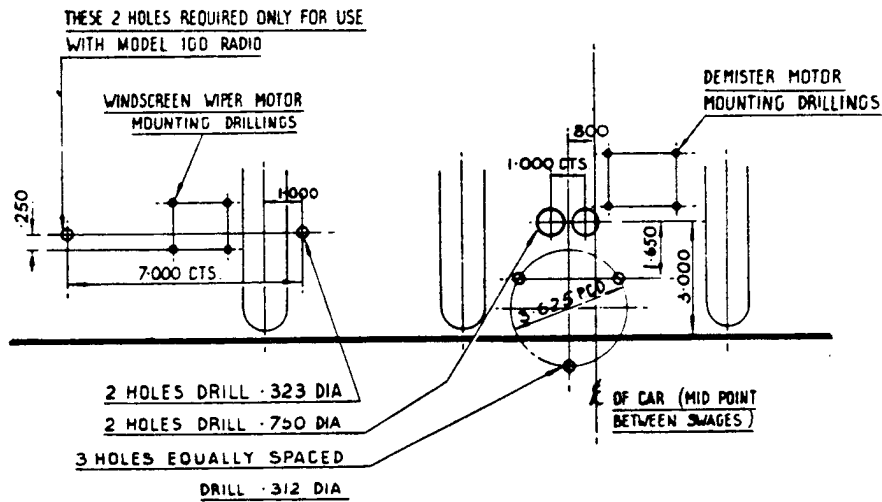

Fig. 4. CHASSIS NO. B.273.EW AND ONWARDS - RIGHT-HAND DRIVE.

ALL COMMUNICATIONS SHOULD BE ADDRESSED TO  
BENTLEY MOTOR SUPPLY LTD, PYMS LANE, CREWE, ENGLAND

# Bulletin

MODEL: BENTLEY MARK VI

- 4 -

## DASHBOARD DRILLING.

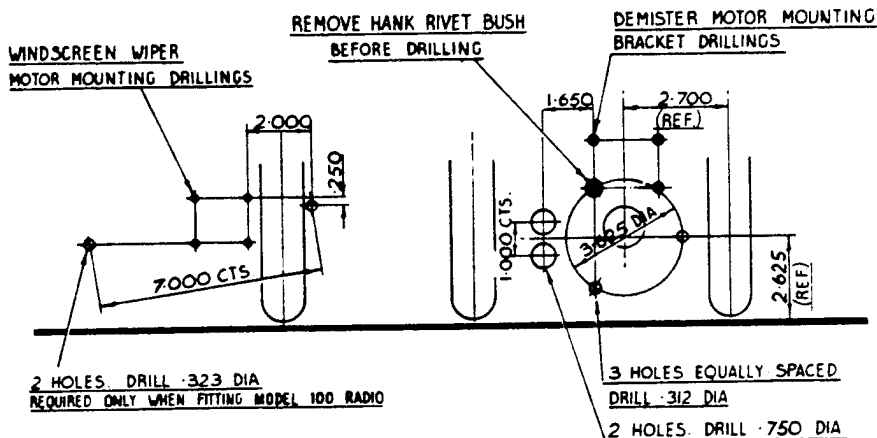

Fig. 5. LEFT-HAND DRIVE CARS.

## ADDITIONAL DASHBOARD DRILLING.

Required only when car is fitted with radios other than Model 100.

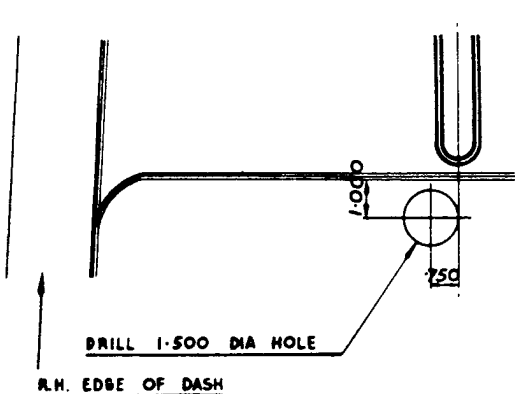

Fig. 6. LEFT-HAND DRIVE CARS.

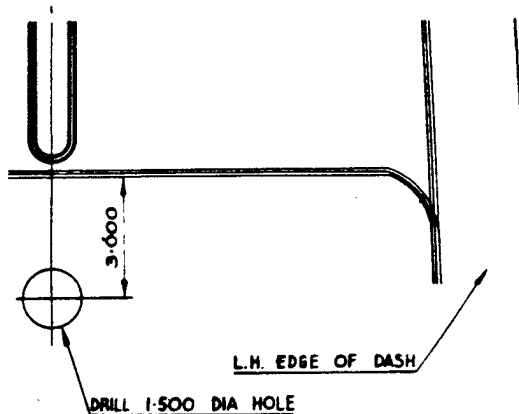

Fig. 7. RIGHT-HAND DRIVE CARS.

ALL COMMUNICATIONS SHOULD BE ADDRESSED TO BENTLEY MOTORS (UK) LTD, 17 THE GARDENS, GUILDFORD, SURREY GU1 1AA

INSTALLATION OF HEATER AND WATER CONNECTIONS:

1. Install the heater and secure with nuts on the engine side of the dashboard. The wires should lead out above the dashboard insulation. When a foot-operated heater is fitted, the handle should be vertically downwards and the 'Y' shaped demister adaptor should be in position on the lid.
2. Fit the two rubber elbows to the inlet and outlet pipes of the heater. The rubber flange should pass through the hole and butt against the back of the dashboard so that the elbow acts as a grommet. The clips should be fitted as close to the dashboard as possible to ensure that they are fully on the projecting pipes.
3. It is necessary to cut the existing feed pipe from the cylinder head to the underseat heater and re-arrange it so that it can be reconnected to the dashboard heater. The lower end of this pipe is fitted with a restrictor, sweated in position, to prevent excessive pressure in the heater. This disc must be removed since a restrictor is fitted in the additional piping supplied.
4. Chassis Nos. B.2.AK - B.271.EW - Right-Hand Drive:

Install the connections as shown in Fig. 9. Remove the one-shot pipe clip situated behind and slightly below the starter solenoid switch, drill out the setscrew hole to  $\frac{1}{2}$ " dia. and fit the heater feed pipe clip supplied.

5. Install the connections as shown in Fig. 8 for R.H. drive cars, Chassis Nos. B.273.EW and onwards; inset shows the arrangement for L.H. drive cars.

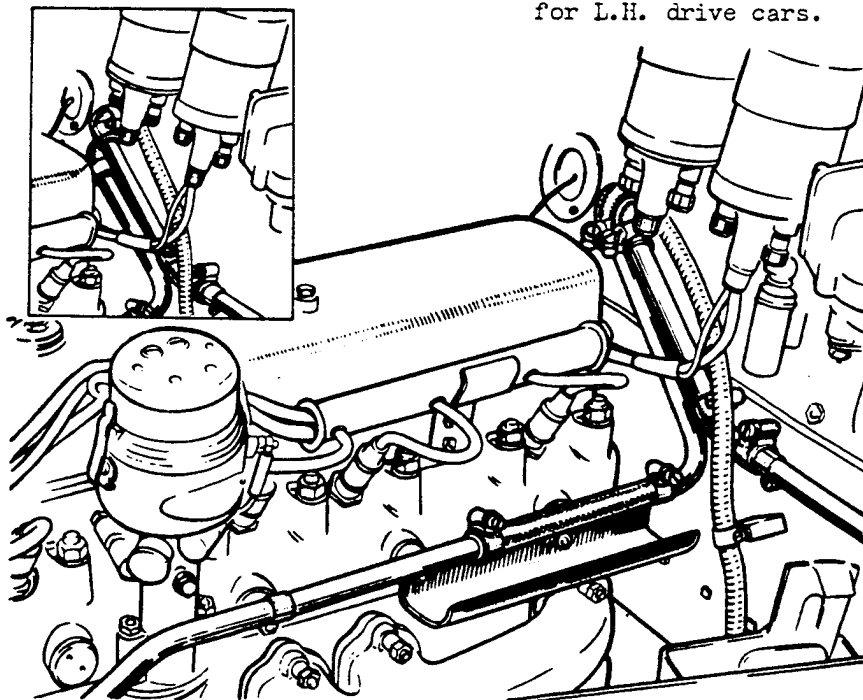

Fig. 8. CHASSIS NOS: B.273.EW AND ONWARDS.

**Bulletin**

MODEL BENTLEY MARK VI

- 6 -

ELECTRICAL CONNECTIONS

1. Remove the instrument panel facia board.
2. Remove the switch marked 'M', enlarge the holes in the instrument panel and facia board and fit the rheostat switch.
3. Chassis No. B.193.DZ and onwards only:

The switch 'P' now becomes switch 'M'.

4. Fit the pass lamp switch in the centre of the facia board as shown at 'A' in Fig. 10. Drill as indicated if the hole does not already exist. If this position is already occupied, the switch can be fitted behind the steering column as shown in Fig. 11.

5. Connect wiring as shown in Fig. 12.

6. Chassis Nos: B.2.AK - B.191.DZ:

The wiring diagram is as in Fig. 12, except that as the demister motor has been removed, the feed from No. 6 fuse will connect direct to the underdash heater rheostat.

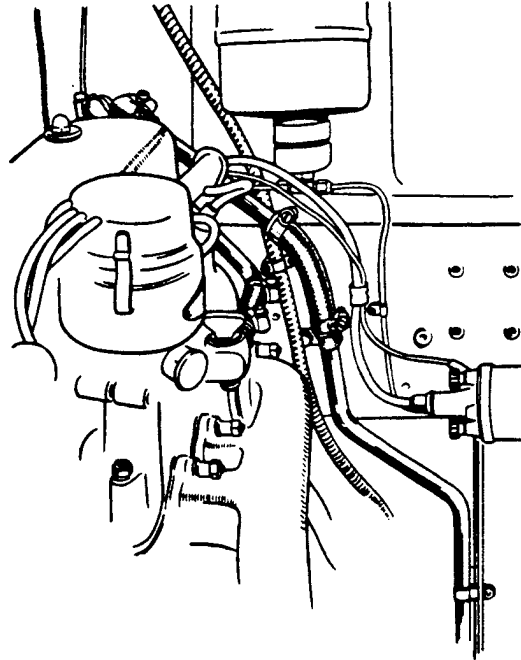

Fig. 9. CHASSIS NOS: B.2.AK - B.271.EW  
RIGHT-HAND DRIVE.

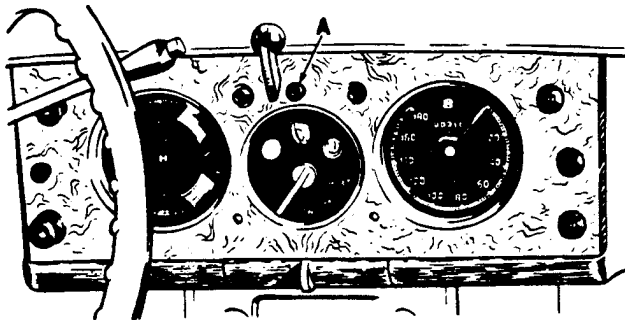

Fig. 10.

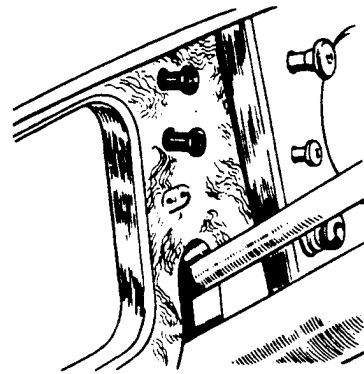

Fig. 11.

ALL COMMUNICATIONS SHOULD BE ADDRESSED TO  
BENTLEY MOTORS LIMITED, 100, THE LANE, CREWE, ENGLAND

# Bulletin

MODEL: BENTLEY MARK VI

- 7 -

MODIFICATION TO RADIO MOUNTINGS:

Cut away the rear of the tray to clear the heater as shown in Fig. 13 and weld on a stiffening rib similar to that already on the tray. Also, drill the  $\frac{1}{4}$ " diameter hole for the radio condenser, attach the condenser and refit the tray. Connect the condenser lead to the heater feed wire at the nearest convenient point.

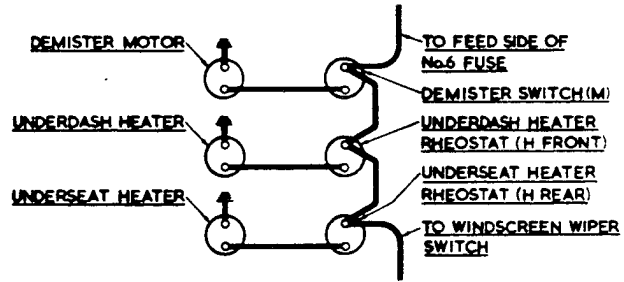

Fig. 12.

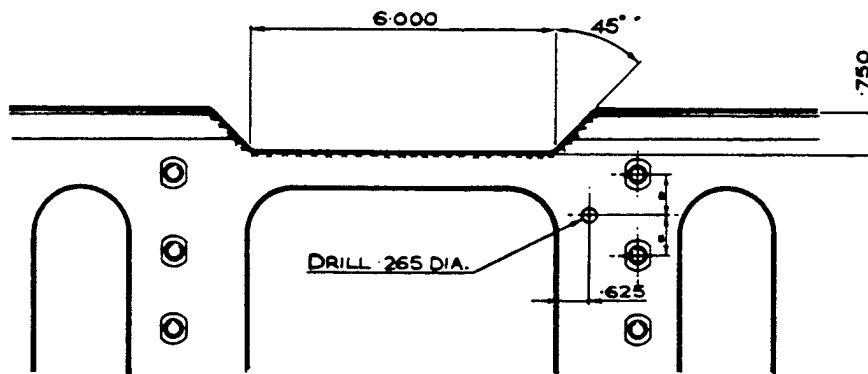

Fig. 13.

1. Model 100 Radio: Right-Hand Drive Cars only:-

Drill a  $\frac{5}{16}$ " hole in the power pack bracket and fit the bracket to the dashboard with the  $\frac{5}{16}$ " hole to the right as shown in Fig. 14. After tightening the nuts, cut off the excess length of screw.

2. Left-Hand Drive Cars:-

Fit the bracket to the dashboard, using the two countersunk screws provided. After tightening the nuts, cut off the excess length of screw.

3. Detach the power pack from the radio set by removing the cover and extracting the three screws which hold the pack to the radio. The pack can be levered off carefully with a screw-driver. Replace the power pack cover.

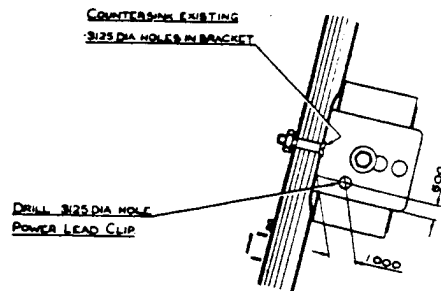

Fig. 14.

ALL COMMUNICATIONS SHOULD BE ADDRESSED TO  
BENTLEY MOTORS (1911) LTD. PYM'S LANE, CREWE, ENGLAND

# Bulletin

MODEL: BENTLEY MARK VI

- 8 -

4. Place the power pack in the bracket with the lead connections away from the dashboard and towards the outside of the car. Secure with the shouldered retaining bolts. These should be fitted with rubber grommets and be placed in the holes nearest the back of the bracket.
5. Clean the contact face of the connecting lead and the corresponding face on the power pack. Fit the lead and secure with two self-tapping screws.
6. Attach the lead clip to the  $5/16"$  hole drilled in the mounting bracket on R.H. cars, or to a convenient pack ventilation hole in the case of L.H. cars.
7. When the heater's demister off-take is to be utilised, re-connect the air silencers to the demister ducts and connect their free ends to the adaptor on the heater.

### RADIO SETS OTHER THAN MODEL 100:

1. Drill the wing valance and fit the power pack and bracket as shown in the appropriate illustrations. (Figs. 15, 16 and 17).
2. Pass the power lead through the hole in the dashboard and connect to power pack and control unit.

NOTE:- Certain radio sets are fitted with a power lead which is connected internally to the control unit and cannot be removed without dismantling the set. In this case, the set should be returned to the London Service Station or to a Radiomobile agent for the longer lead to be fitted. This applies particularly if the set is in guarantee.

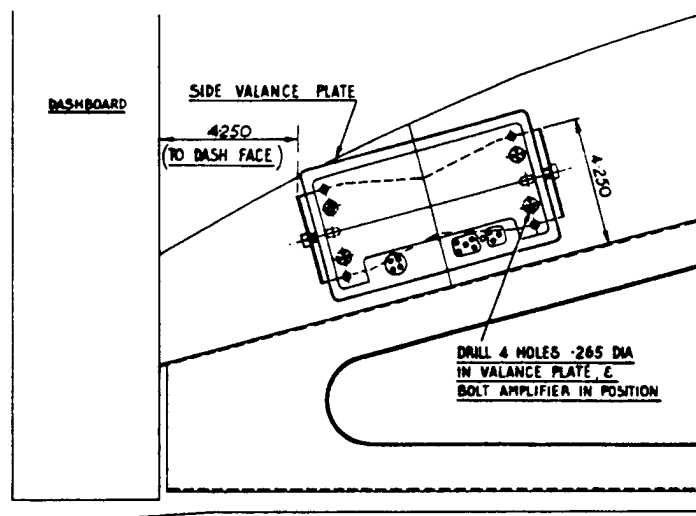

Fig. 15. R.H. CARS.

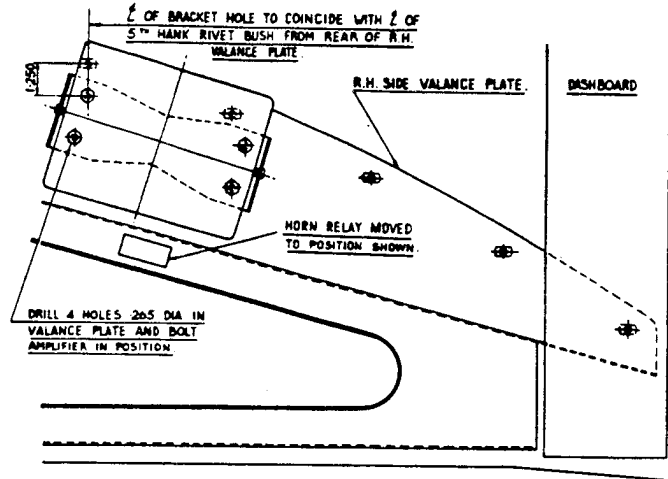

Fig. 16. L.H. CARS.

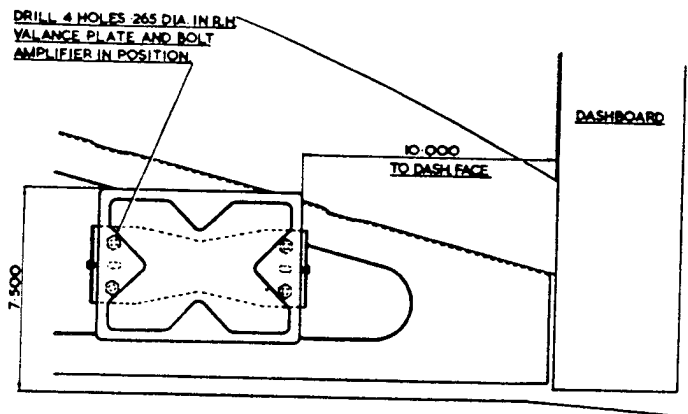

Fig. 17. L.H. CARS FITTED WITH COLD AIR DEMISTER.

COMPLETION OF INSTALLATION:

Refit the Radio.

If there is insufficient clearance between the heater and the radio, the set may be moved forward about  $\frac{1}{4}$ " by redrilling the fixing flanges, but care must be taken that the appearance of the facia board is not spoilt by having the set too far forward.

Clip the power lead up so that it is well clear of the passenger's or driver's feet.

**Bulletin**

MODEL: BENTLEY MARK VI

- 10 -

Fill the coolant system and test the installation for operation and water leaks.

SERVICE REPLACEMENTS

In the event of replacements being required, it will be noted from the List of Parts, that heater components are now available, thus obviating the changing of the whole assembly. This also applies to heaters of earlier patterns.

ALL COMMUNICATIONS SHOULD BE ADDRESSED TO

BENTLEY MOTORS (1931) LTD. FFM'S LANE CREWE ENGLAND

**Bulletin**

MODEL BENTLEY MARK VI

- 11 -

LIST OF PARTS(Chassis Nos. B.2.AK - B.191.DZ)

Heater - demister comprising:-

R-4788	Motor Assembly	1 Off
R-4789	Impellor	1 "
R-4786	Cover	1 "
R-4785	Matrix	1 "
R-4392	Clips	3 "
R-4570	Rubber Elbow	2 Off
R-4576	Pipe, Feed	1 "
R-4577	Pipe, Feed	1 "
RE-9418	Clip, Jubilee size 00	8 "
R-4092	Hose	1 "
R-4093	Hose	1 "
RD-5229	Suppressor	1 "
CS-30200	Screw	1 "
K-9008	S/Washer	1 "
K-4008	Nut	1 "
RD-6633	Mounting Bracket, Fog Lamp Switch	1 "
RD-3441	Heater Rheostat	1 Off
R-4546	Heater Rheostat Knob (Front)	1 "
R-4547	Heater Rheostat Knob (Rear)	1 "
R-4071	Split Bracket Assembly	1 Off
R-4073	Lead, Pack/Radio	1 "
R-4141	Screw	2 "
R-4142	Nut	2 "
K-9009	Washer	2 "
RD-3434	Clip, Lead	1 "
RE-6231	Clip, Pipe	1 Off
RE-4745	Clip, Pipe	1 "
K-2019	Screw	1 "
K-9008	S/Washer	2 "
KC-904	Setscrew	1 "
K-4008	Nut	1 "
R-4129	'Y' Piece	1 "
R-4842	Air Hose	1 "
R-4843	Air Hose	1 "

Occasional cars may be encountered with the old pattern long air silencer, or even without silencer. In such cases, the following should be fitted as required:-

RD-4570	Silencer	2 Off
RD-3426	Connector	2 "
RD-4994	Clip, Jubilee No. 2.	2 "

ALL COMMUNICATIONS SHOULD BE ADDRESSED TO

BENTLEY MOTORS (UK) LTD. PYMS LANE, CREWE, ENGLAND

**Bulletin**

MODEL : BENTLEY MARK VI

- 12 -

Chassis Nos. B.193.DZ - B.271 EW:

## Heater Comprising :-

R-4788	Motor Assembly	1	Off
R-4789	Impellor	1	"
R-4787	Cover	1	"
R-4785	Matrix	1	"
R-4398	Clips	3	"
R-4570	Rubber Elbow	2	Off
R-4576	Pipe, Feed	1	"
R-4577	Pipe, Feed	1	"
RE-9418	Clip, Jubilee Size 00.	8	"
R-4092	Hose	1	"
R-4093	Hose	1	"
RD-5229	Suppressor	1	"
CS-30200	Screw	1	"
K-9008	S/Washer	1	"
K-4008	Nut	1	"
RD-6633	Mounting bracket, Fog Lamp switch	1	"
RD-3441	Heater Rheostat	1	Off
R-4546	Heater Rheostat Knob (Front)	1	"
R-4547	Heater Rheostat Knob (Rear)	1	"
R-4071	Split Bracket Assembly	1	Off
R-4073	Lead, Pack/Radio	1	"
R-4141	Screw	2	"
R-4142	Nut	2	"
K-9009	Washer	2	"
RD-3434	Clip, Lead	1	"
RE-6231	Clip, Pipe	1	Off
RE-4745	Clip, Pipe	1	"
K-2019	Screw	1	"
K-9008	S/Washer	2	"
KC-904	Setscrew	1	"
K-4008	Nut	2	"

Chassis Nos. B.273 EW onwards:

## Heater Comprising :-

R-4788	Motor Assembly	1	Off
R-4789	Impellor	1	"
R-4787	Cover	1	"
R-4785	Matrix	1	"
R-4398	Clips	3	"



MODEL BENTLEY MARK VI

- 13 -

	R-4570	Rubber Elbow	2 Off
	R-4576	Pipe, Feed	1 "
	R-4577	Pipe, Feed	1 "
	RE-9418	Clip, Jubilee Size 00.	6 "
	R-4092	Hose	1 "
	R-4093	Hose	1 "
	RD-5229	Suppressor	1 "
	CS-30200	Screw	1 "
	K-9008	S/Washer	1 "
	K-4008	Nut	1 "
	ED-6633	Mounting Bracket, Fog Lamp Switch	1 "
	RD-6694	Heater Switch (3 Positions)	1 Off
A	R-4807	Knob Heater Switch (Front)	1 "
	R-4808	Knob Heater Switch (Rear)	1 "
	RD-3441	Heater Switch (Rheostat)	1 Off
B	R-4546	Knob Heater Switch (Front)	1 "
	R-4547	Knob Heater Switch (Rear)	1 "

- A. Used on all cars fitted with 3 Position Heater Switch.  
 B. Used on all cars fitted with Rheostat Heater Switch.

Additional material required only when car is fitted with  
 Model 100 Radio:-

	R-4071	Split Bracket Assembly	1 Off
	R-4073	Lead Pack/Radio	1 "
	R-4141	Screw	2 "
	R-4142	Nut	2 "
	K-9009	Washer	2 "
	RD-3434	Lead Clip	1 "

Material required when car is fitted with Radios other than  
 Model 100:-

	R-4858	Mounting Bracket, Amplifier Unit	1 Off
	K-2010	Screw	4 "
	K-9008	S/Washer	4 "
	K-4008	Nut	4 "
	R-4791	Shield, Amplifier	1 "
	CS-31020	Screw	4 "

**Bulletin**

MODEL: BENTLEY MARK VI

FOR INFORMATION'BIRMABRIGHT' ALUMINIUM ALLOY

The Bentley 'R' Type boot lid is manufactured from Birmal Sheet BB-3, a light, non-corrosive, aluminium alloy containing magnesium. This Bulletin gives information of the recommended procedure for welding and filling where repairs are necessary due to accidental damage.

In general, small welds and fillings may be carried out as described with excellent results but prolonged heating is apt to cause surface distortions which cannot be satisfactorily beaten out. Where damage is at all extensive a new boot lid should be fitted.

Material Required

<u>Welding Rod</u>	Birmabright No.2
<u>Flux</u>	'Welding Flux for Aluminium and its Alloys'
<u>Filler</u>	Birmetal Filzall
<u>Lubricant</u>	Aluminium Powder.

These materials are available from Messrs. Birmabright Ltd., Woodgate Works, Quinton, Birmingham, 32.

Messrs Birmabright Ltd., are also offering a complete kit containing a good supply of all necessary consumable materials, a S.I.F. Welding Torch, three wooden paddles and an electrically heated paddle. The Kit is packed in an anodised case for carriage and storage. Retailers interested are asked to write direct for a quotation. All items can, of course, be purchased separately.

WELDING:

The welding procedure closely follows that for pure aluminium but the welding rod specified must be used. The 'leftwards' technique should be employed and, after initial tacking, the weld should be completed in one run as quickly as possible.

- (i) Strip the paint as necessary with cellulose stripper. Thoroughly clean the edges to be welded with wire wool for a width of not less than  $\frac{1}{2}$ " on both surfaces of the metal.
- (ii) Mix a small quantity of the flux with water to a smooth paste and brush it on to the cleaned edges on both sides of the metal. Clean the welding rod with wire wool and brush it over with flux paste.
- (iii) Using a No.2 nozzle on British Oxygen Company or S.I.F. Torches, or its equivalent on other torches, adjust the flame so that it is slightly reducing; that is, it has a slight excess of acetylene. The flame should be smooth and quiet.

ALL COMMUNICATIONS SHOULD BE ADDRESSED TO  
BENTLEY MOTORS (1931) LTD., SERVICE STATION, HYTHE ROAD, WILLESDEN, LONDON, W.11

**Bulletin**

MODEL: BENTLEY MARK VI

- 2 -

- (iv) Tack weld at intervals of 2" to 4" (50 to 100 mm) and then complete the weld in one run working from right to left. Allow to cool naturally. Do not quench.
- (v) When cool, wash off any surplus flux with hot water and a scrubbing brush. This is essential owing to the strongly corrosive nature of the flux used.
- (vi) Dress with a Dreadnought file and spray paint in the usual way.

**FILLING**

'Birmetal Filzall' is a thermal plastic resin of 75% aluminium powder and 25% synthetic resin and has a melting point of approximately 120°C. It is applied in a similar way to normal metallic solders and little heat is required. If an oxyacetylene flame is used it should be neutral and soft and only the tip of the outer flame should contact the metal.

- (i) Remove the paint as necessary with cellulose stripper.
- (ii) Thoroughly clean the surface with coarse sand-paper. This provides a rough surface to which the filler can adhere. Cleaning with a wire brush is insufficient.
- (iii) Apply a thin coat of filler over the whole working surface. To ensure good adhesion, heat the surface and allow the Filzall stick to melt in contact with the surface. Do not play the flame direct onto the stick.
- (iv) Build up the surface as necessary with filler playing the flame over the coated area and on the end of the stick as necessary. Overheating will cause the filler to turn brown and will produce holes in the finished surface.
- (v) Level off the filler with wooden paddles rubbing the paddles in aluminium powder to prevent the filler from sticking to them.
- (vi) When cold, feather off with a 'Dreadnought' file and rub down in the usual way. If a sanding disc is employed, use the reverse face of the disc and apply light pressure with the edge of the disc to create a glaze by friction.
- (vii) Repainting

The first two priming coats should be applied as mist coats with the minimum of thinners. The filler softens in contact with cellulose thinners, but will harden off as the thinners evaporates. The use of stopper is not recommended but if necessary it should be applied as stiff as possible.

After two mist coats continue spraying in the usual way.

**Bulletin**

MODEL : BENTLEY MARK VI

- 3 -

The electrical paddle supplied by Messrs Birnabright Ltd., enables a filling to be made without the use of a flame and requires no aluminium powder as a lubricant. A smooth surface can be obtained that requires little hand dressing before painting.

ALL COMMUNICATIONS SHOULD BE ADDRESSED TO

BENTLEY MOTORS (1931) LTD. SERVICE STATION, HYTHE ROAD, WILLSDEN, LONDON, N.W.10

SB/VK/CL. 1/JN...25.1.54.

PRINTED IN ENGLAND

SECTION U

**Bulletin**

MODEL: BENTLEY MARK VI

FOR INFORMATION:STOWAGE OF SUITCASES.

Retailers are advised that some owners have found difficulty in correctly stowing the special Bentley supplied suitcases.

For information, the correct sequence is given below, and retailers are asked to advise and demonstrate to all purchasers on delivery.

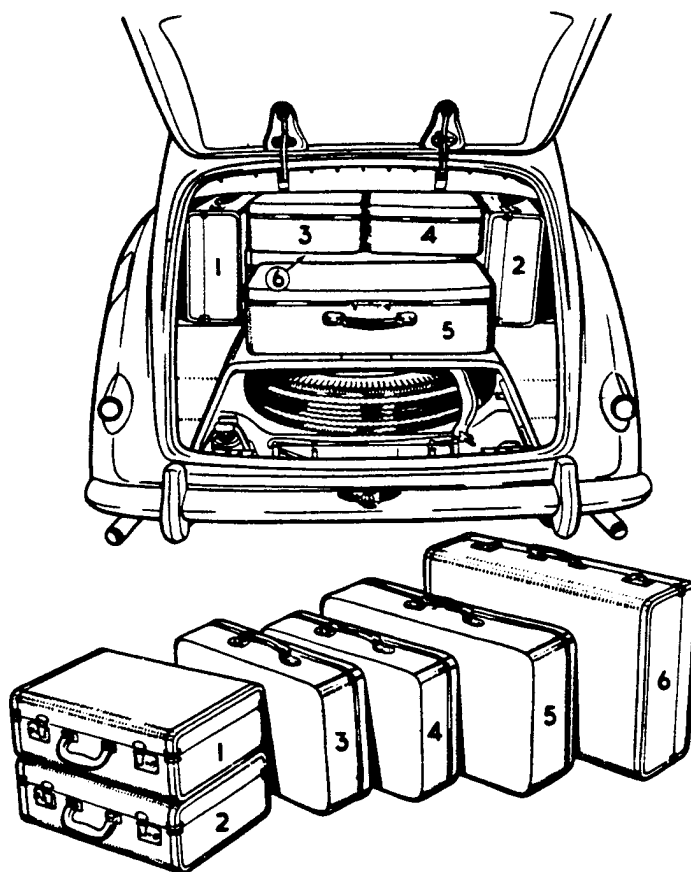

ILLUSTRATING CORRECT METHOD OF STOWAGE.

The largest suitcase, No.6, must be placed centrally and as far back as possible into the boot, the smaller cases, 1 and 2, are then packed at each side of No.6. Nos. 3 and 4 should then be laid on top of No.6 and, finally, the second largest case, No.5, placed in position to fit snugly between No.6 and the boot lid.

**Bulletin**

MODEL: BENTLEY MARK VI

FOR INFORMATION.BENTLEY CONTINENTAL SALOON.REMOVAL AND REPLACEMENT OF WINDSCREENS.METAL FRAME TYPE - CURVED GLASS.

In order to facilitate the above, the coachbuilders have prepared the following instructions.

To Remove.

1. Remove the driving mirror and the two sun vizors.
2. Remove the two top metal fillets.
3. Remove the two nuts visible under the outer side of the shelf below the instrument board, and the two raised headed screws below the inner side of the shelf. The shelf can then be removed complete with cubby hole door.
4. Remove the polished wood face panel below the centre of the instrument board, secured by screws at the back of the panel.
5. Remove the two metal thread screws from the bracket at each end of the instrument board, and the four screws from the polished lower screen rail.
6. Disconnect the positive battery terminal to ensure against shorting a live wire while easing back the instrument board later.
7. Disconnect the speedometer, tachometer, charging socket and the screen washer from behind the instrument board.
8. Ease back the instrument board and screen rail, giving access to the five securing screws at the bottom of the screen.
9. Remove the screws from the metal fillets on each side of the screen. These fillets may be left in position.
10. Detach the head lining from the front of the roof behind the top of the screen giving access to the fixing brackets. Remove the five screws from these brackets and five from the blocks at the bottom of the screen.
11. Remove the screen from the body.
12. To remove the radio, remove the two securing bolts on either side of the radio, when the receiver and brackets can be dismantled.

**Bulletin**

MODEL: BENTLEY MARK VI

- 2 -

To Replace the Glass.

It should be noted when replacing the glass that it must be sealed in the frame by means of "Prestik" sealing tape led round the edge of the glass. The glass should then be put into the metal frame and the screen refitted to the body, the surplus "Prestik" then pushed gently into the frame so that it is completely sealed.

When the "Prestik" has been pressed into the frame all the way round the glass, any surplus edges should be carefully cut off with a sharp knife, taking care not to scratch the glass. The dismantled parts can then be replaced in the reverse order of dismantling.

**Bulletin**

MODEL: BENTLEY MARK VI

FOR INFORMATION.CARAVAN OR TRAILER TOWING ATTACHMENT.

A Caravan or Trailer towing attachment approved by Rolls-Royce Limited and Bentley Motors (1931) Limited, is available for all cars fitted with standard steel saloon bodies.

Illustrations and details of price are obtainable from Messrs. B. Dixon-Bate Limited, of Bridge Works, Chester.

This attachment has been so designed that visible parts can be removed when not required, so that the appearance of the car can be restored to normal.

**Bulletin**

MODEL : BENTLEY MARK VI

FOR INFORMATIONTRICO WINDSCREEN WASHER CONTROL VALVE

Prior to July 1956, the windscreen washer control valve, Part No. R. 4120, was fitted with a valve seat giving metal to metal contact. Trouble was experienced with this control valve owing to the metal to metal seating having a tendency to leak, causing poor engine idling. To overcome this problem, the design was changed to incorporate a valve seat of natural rubber.

Further trouble was encountered in the form of intermittent or complete failure of the control valve to operate the windscreen washer. This failure was caused through damage of the natural rubber seat on the sharp edge of the valve seating. Accordingly, in February this year, the design of the control valve was changed to incorporate a Neoprene seat in place of natural rubber. To identify the modified control valve, it was marked with a spot of green paint on the side of the valve housing.

To date, this change has proved entirely satisfactory and it has been decided that this control valve will be supplied for all replacements. All control valves supplied will now have the Neoprene seat but they will not necessarily have the green identification mark.