

Hydraulic systems

Contents	Sections					
	Silver Spirit Mulsanne	Silver Spur	Mulsanne Turbo	Bentley Eight	Bentley Turbo R	Comiche/ Continental
Introduction	G1	G1	G1	G1	G1/1	G1
Special precautions (including system contamination test procedure)	G2	G2	G2	G2	G2/1	G2
Hydraulic system pipework	G3	G3	G3	G3	G3/1	G3
Bleeding the hydraulic systems	G4	G4	G4	G4	G4/1	G4
Hydraulic mineral oil reservoirs	G5	G5	G5	G5	G5/1	G5
Hydraulic pumps	G6	G6	G6	G6	G6	G6
Hydraulic accumulators	G7	G7	G7	G7	G7/1	G7
Deceleration conscious pressure limiting valve	G8	G8	G8	G8	G8	G8
Brake distribution valves	G9	G9	G9	G9	G9	G9
Brake actuation linkage assembly	G10	G10	G10	G10	G10	G10
Priority valves/pressure switches	G11	G11	G11	G11	G11/1	G11
Height control valves	G12	G12	G12	G12	G12/1	G12
Restrictor - height control valves/ minimum pressure valves	G13	G13	G13	G13	—	G13
Restrictor, one-way valve, and filter	—	—	—	—	G13/1	—
Minimum pressure valves	G14	G14	G14	G14	G14	G14
Gas springs and Suspension struts	G15	G15	G15	G15	G15	G15
Front and rear disc brakes	G16	G16	G16	G16	G16	G16
Parking brake linkage	G17	G17	G17	G17	G17	G17
Fault diagnosis	G18	G18	G18	G18	G18	G18
Special torque tightening figures	G19	G19	G19	G19	G19	G19
Workshop tools	G20	G20	G20	G20	G20	G20



Issue record sheet 1

April 1985

The dates quoted below refer to the issue date of individual pages within this chapter.

Sections	G1	G1/1	G2	G2/1	G3	G3/1	G4	G4/1	G5	G5/1
Page No.										
Contents										
1	Apr 85	Apr 85	Apr 85	Apr 85	Nov 84	Apr 85	Jun 83	Apr 85	May 84	Apr 85
2	Apr 85	Apr 85			Nov 84		Jun 83	Apr 85	May 84	Apr 85
3	Jun 83	Apr 85	Sep 84		Jun 83		Jun 83	Apr 85	May 84	
4	—	—	Jun 83						May 84	
5	Jun 83	Apr 85	Sep 84						May 84	
6	—	—	Jun 83						May 84	
7	Jun 83	Apr 85	Jun 83							
8	—	Apr 85								
9	Jun 83									
10	—									
11	Jun 83									
12	—									
13	Jun 83									
14	—									
15	Apr 85									
16	—									
17	Apr 85									
18	—									
19	Apr 85									
20	Apr 85									
21										
22										
23										
24										
25										
26										
27										
28										
29										
30										
31										
32										
33										
34										
35										
36										
37										
38										
39										
40										
41										
42										
43										
44										
45										
46										
47										
48										

Issue record sheet 2

September 1985

The dates quoted below refer to the issue date of individual pages within this chapter.

Sections	G6	G7	G7/1	G8	G9	G10	G11	G11/1	G12	G12/1
Page No.										
Contents										
1	Mar 85	Jun 83	Apr 85	Jun 83	Jun 83	Aug 85	Sep 83	Apr 85	Sep 85	Apr 85
2	Mar 85	Jun 83	Apr 85	Jun 83	Jun 83		Sep 83	Apr 85	Sep 85	Apr 85
3	Mar 85	Jun 83				Aug 85			Sep 85	
4	Mar 85	Jun 83				Aug 85			Sep 85	
5		Jun 83				Aug 85				
6						Aug 85				
7						Aug 85				
8						Aug 85				
9										
10										
11										
12										
13										
14										
15										
16										
17										
18										
19										
20										
21										
22										
23										
24										
25										
26										
27										
28										
29										
30										
31										
32										
33										
34										
35										
36										
37										
38										
39										
40										
41										
42										
43										
44										
45										
46										
47										
48										

Special precautions (including system contamination test procedure)

Contents	Pages					
	Silver Spirit Mulsanne	Silver Spur	Mulsanne Turbo	Bentley Eight	Bentley Turbo R	Corniche/ Continental
Warning	G2-3	G2-3	G2-3	G2-3	G2/1-1	G2-3
Hydraulic system mineral oil (LHM)	G2-3	G2-3	G2-3	G2-3	G2/1-1	G2-3
Components identification	G2-3	G2-3	G2-3	G2-3	G2-3	G2-3
Cleanliness	G2-4	G2-4	G2-4	G2-4	G2-3	G2-4
Hydraulic system mineral oil (LHM) contamination test kit and procedure	G2-4	G2-4	G2-4	G2-4	G2-4	G2-4
Test kit	G2-4	G2-4	G2-4	G2-4	G2-4	G2-4
First procedure	G2-4	G2-4	G2-4	G2-4	G2-4	G2-4
Workshop procedure (to be carried out when contamination is suspected)	G2-4	G2-4	G2-4	G2-4	G2-4	G2-4
Test procedure for determining hydraulic system mineral oil (LHM) contamination	G2-5	G2-5	G2-5	G2-5	G2-5	G2-5
Examination of results	G2-5	G2-5	G2-5	G2-5	G2-5	G2-5
Depressurizing the system	G2-5	G2-5	G2-5	G2-5	G2/1-1	G2-5
Method 1	G2-5	G2-5	G2-5	G2-5	—	G2-5
Method 2	G2-5	G2-5	G2-5	G2-5	—	G2-5
Accumulator and Gas spring spheres	G2-5	G2-5	G2-5	G2-5	G2-5	G2-5
Bleeding the hydraulic systems	G2-5	G2-5	G2-5	G2-5	G2-5	G2-5
General information	G2-6	G2-6	G2-6	G2-6	G2-6	G2-6
Removing components	G2-6	G2-6	G2-6	G2-6	G2-6	G2-6
Cleaning components	G2-7	G2-7	G2-7	G2-7	G2-7	G2-7
Servicing equipment	G2-7	G2-7	G2-7	G2-7	G2-7	G2-7
Hydraulic systems - Filling or topping-up	G2-7	G2-7	G2-7	G2-7	G2-7	G2-7
Servicing rubber components	G2-7	G2-7	G2-7	G2-7	G2-7	G2-7
Fitting replacement units	G2-7	G2-7	G2-7	G2-7	G2-7	G2-7
Storage and transportation	G2-7	G2-7	G2-7	G2-7	G2-7	G2-7

Special precautions (including system contamination test procedure)



WARNING

Use only Hydraulic System Mineral Oil (LHM) to replenish the braking and levelling systems.

Do not use Brake Fluids (Castrol RR363, Universal, or any other type). The use of any other type of brake fluid, even in very small amounts, will cause component failure necessitating extensive rectification to the braking and levelling systems of the car.

Always ensure before fitting any seals, hoses, pipes, etc., that they are suitable for a mineral oil system. For details of correct component identification reference should be made to Section G2 of this Workshop Manual.

Always ensure that a sealed container(s) of Hydraulic System Mineral Oil (LHM) is fitted adjacent to the battery.

Always ensure that no foreign matter enters the systems when work is being carried out.

All instructions, operations, and procedures are as stated in Section G2, other than the method. Depressurizing the system.

Depressurizing the system

Open the bleed screw on both accumulators and allow sufficient time for the mineral oil pressure to discharge back to the reservoir. These bleed screws are an integral part of the accumulator, the mineral oil being allowed to flow from the accumulator sphere back to the reservoir when the bleed screw is opened (see fig. G7/1-1). Switch on the ignition and check that the facia warning panels marked \odot 1 BRAKE PRESSURE and/or \odot 2 BRAKE PRESSURE are illuminated.

To depressurize the rear suspension struts, place a bleed tube to the struts bleed screw. Open the bleed screw and allow the hydraulic system mineral oil to bleed into a clean container until the flow ceases.



WARNING

Do not use equipment that has been used on cars utilizing synthetic brake fluid i.e. RR363, when carrying out bleeding operations on cars using Hydraulic System Mineral Oil (LHM). Failure to observe this warning will result in contamination of the hydraulic systems, necessitating extensive and expensive rectification.

Introduction

In order to obtain optimum performance of the hydraulic systems, it is essential that they are free of air at all times. The two hydraulic systems are recirculatory and therefore, if air is allowed to enter them at any point it will reduce the efficiency.

Bleed screws are provided on the side of the accumulators, on each pair of brake calipers, one on the inner sill forward of the rear road spring for the rear suspension struts and one on the conscious pressure limiting valve. A bleed screw is also incorporated into the number 2 system situated adjacent to the pressure switch. The accumulator bleed screws are an integral part of the valve housing and do not require the connection of a bleed pipe during the bleeding operation.

The accumulators are mounted at the rear of the crankcase on the 'B' bank side of the engine. The accumulator for the number 1 system is vertically mounted and the number 2 system accumulator horizontally mounted.

The two hydraulic system mineral oil reservoirs are situated on the left-hand side of the engine compartment.

The inboard hydraulic reservoir supplies hydraulic system mineral oil for the number 1 system. From the reservoir, mineral oil is supplied to the front brake pump, which in turn supplies hydraulic system mineral oil under pressure to the vertically mounted accumulator, the upper distribution valve, the front brake calipers on the front wheels, the upper cylinders of the rear brake calipers, and the rear suspension struts.

The outboard reservoir supplies hydraulic system mineral oil for the number 2 system. From the reservoir, mineral oil is supplied to the rear brake pump which in turn supplies hydraulic system mineral oil under pressure to the horizontally mounted accumulator, the lower distribution valve, the pressure

Bleeding the hydraulic systems

switch, the rear brake calipers on the front wheels, and the lower cylinders of the rear brake calipers.

When a rectification has been carried out between the brake pumps and the distribution or height control valves it will be necessary to bleed at all the bleed points in that particular circuit.

However, if a rectification has been carried out between the distribution valves and the brake calipers, it should only be necessary to bleed at the bleed points between the distribution valve and the calipers in the faulty circuit.

Whenever in doubt it is advisable to bleed the complete system.

The power brake circuits should be bled at low pressure, ensuring that the systems are depressurized and the mineral oil levels in the reservoirs are kept above the minimum marks at all stages of the bleeding operation.

To obtain low pressure bleeding of the system(s), depress the brake pedal and open the relevant bleed screw before starting the engine and running it at 1000 rev/min. This ensures the accumulator remains at low pressure. Throughout the bleeding operation, the brake pressure warning panel(s) marked Ⓢ 1 BRAKE PRESSURE and/or Ⓢ 2 BRAKE PRESSURE should be illuminated. Only when bleeding the suspension struts should the systems be fully pressurized and the warning panel lamps extinguished.

When bleeding the suspension struts, the interior of the car should be weighted to compress the suspension sufficiently for the height control valves to actuate, thus allowing pressurized mineral oil to flow to the suspension struts and bleed screw. The engine should be allowed to run for four minutes prior to bleeding, to ensure the systems are fully charged. Bleed the suspension struts until all the bubbles have been expelled then allow fifteen seconds to elapse before fully tightening the bleed screw.

Bleeding the systems

The following information is a comprehensive bleeding operation which should be carried out to ensure removal of air from the complete hydraulic systems. However, as previously stated, each system can be bled separately at all points downstream of any replacements or pipe disconnections (refer to Sectional bleed requirements on page G4/1-3). However, if any doubt exists, it is advisable to bleed the complete system concerned.

Whilst bleeding is being carried out, it is essential that the mineral oil level in the two reservoirs is kept to at least the topping-up mark on the level indicator plate, using clean hydraulic system mineral oil.

Reference should be made to Chapter D for approved types.

All bleed screws should be torque tightened in accordance with the figures quoted in Section G19.

When bleeding the hydraulic systems ensure that only equipment suitable for hydraulic system mineral oil is used. See Warning, on page G4/1-1.

Attach a length of bleed tube to each bleed screw prior to the bleed screw being opened. Immerse the free end of the tube in approximately 25.4 mm (1 in) of hydraulic system mineral oil contained in a clean bottle.

Bleed tube attachment is not necessary when bleeding the accumulators, as bleeding is effected internally through the accumulator valve housing, the mineral oil being allowed to flow back to its respective reservoir when the bleed screw is released approximately one revolution (see fig. G7/1-1).

With the gear selector in the Park position and the parking brake applied the following sequence of operations should be carried out (refer to fig. G4/1-1), after first noting the following.

System 1 bleed points are A, D, F, H, J, L, and N.
System 2 bleed points are B, C, E, G, K, and M.

When bleeding the suspension struts extra care should be taken when slackening the bleed screw as the system will be operating at full pressure.

Any hydraulic system mineral oil that has been spilt onto the tyres must be removed. The use of a soap solution and a final rinse with clean water is recommended for this purpose.

Under no circumstances should hydraulic system mineral oil be allowed to remain on the tyres for prolonged periods as this will cause tyre damage.

1. Remove the gearchange thermal cut-out from the fuseboard.
2. Depressurize the hydraulic systems as described in Section G2/1. Complete depressurization of the suspension struts is not necessary.
3. Open the accumulator bleed screws, points A and B.
4. Start and run the engine at 1500 rev/min for one minute. Ensure that the facia warning panels marked $\text{Q} 1$ BRAKE PRESSURE and/or $\text{Q} 2$ BRAKE

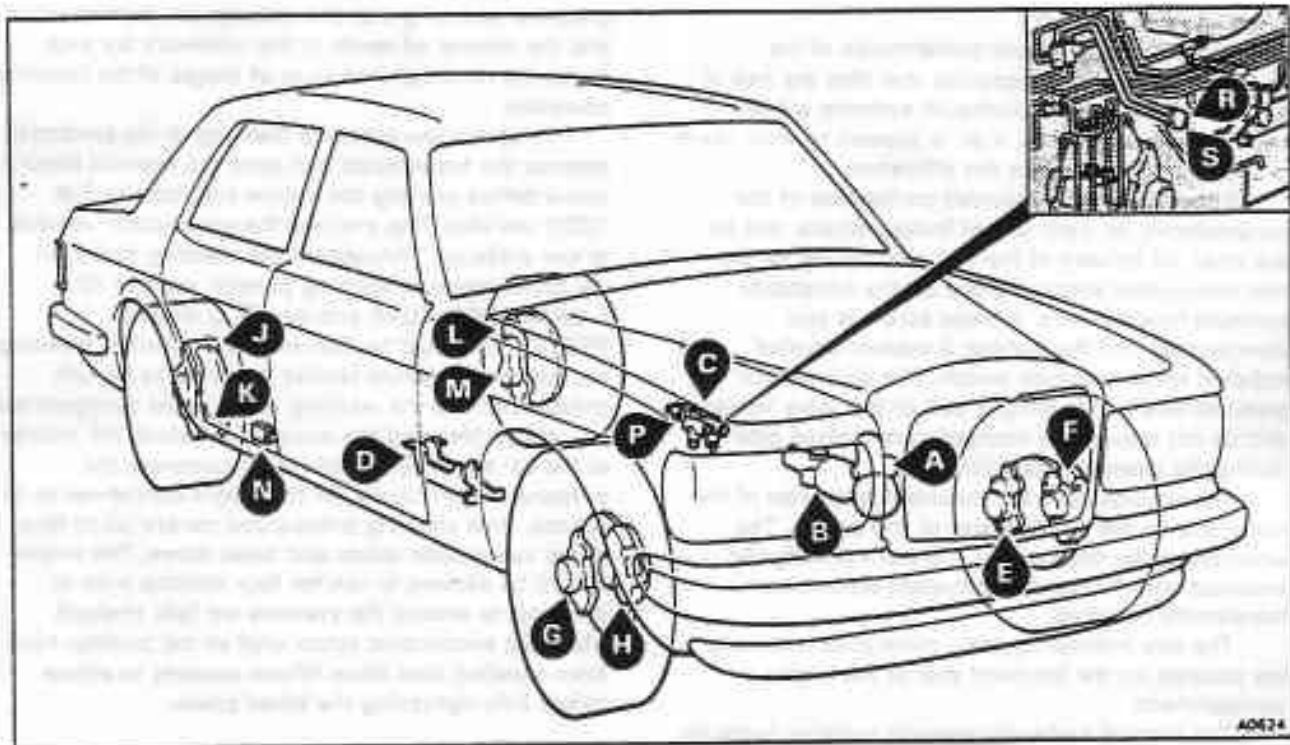

Fig. G4/1-1 Mineral oil hydraulic system bleed points and accumulator test service points
(Inset - Left-hand drive cars)

- | | | | |
|---|--|---|---|
| A | Accumulator (No. 1 system) | L | Left-hand rear caliper (upper cylinder) |
| B | Accumulator (No. 2 system) | M | Left-hand rear caliper (lower cylinder) |
| C | Pressure switch (No. 2 system) | N | Rear suspension struts (right-hand side inner sill forward or rear road spring) |
| D | Deceleration conscious pressure limiting valve | P | High pressure (red line No. 1 system) right-hand drive cars |
| E | Rear caliper left-hand front wheel | R | High pressure (red line No. 1 system) left-hand drive cars |
| F | Front caliper left-hand front wheel | S | High pressure (orange line No. 2 system) left-hand drive cars |
| G | Rear caliper right-hand front wheel | | |
| H | Front caliper right-hand front wheel | | |
| J | Right-hand rear caliper (upper cylinder) | | |
| K | Right-hand rear caliper (lower cylinder) | | |

PRESSURE are illuminated.

5. Switch off the engine.
6. Close the accumulator bleed screws, points A and B.
7. Open the pressure switch bleed screw C, allow bleeding to start (right-hand drive cars only).
8. Allow point C to bleed until air free. Close bleed screw C (right-hand drive cars only).
9. Open bleed screws at points D, E, and F.
10. Depress the footbrake pedal.
11. Start and run the engine at 1000 rev/min.
12. Allow points at D, E, and F to bleed until air free.
13. Open bleed screws G and H, allow bleeding to start.
14. Close bleed screws at points D, E, and F.
15. Allow points at G and H to bleed until air free.
16. Open bleed screws at points J and K.
17. Close bleed screws at points G and H.
18. Allow points at J and K to bleed until air free.
19. Open bleed screws at points L and M.
20. Close bleed screws at points J and K.
21. Allow points at L and M to bleed until air free.
22. Close bleed screws at points L and M.
23. Release the footbrake pedal.
24. Add weight to rear of car to actuate the levelling valves.
25. Allow the systems to pressurize (facia warning panels extinguished).
26. Open the bleed screw at point N, bleed until air free.
27. Close the bleed screw at point N.
28. Check the hydraulic system mineral oil levels in the reservoirs and top-up as necessary.
29. Switch off the engine.
30. Fit a rubber dust cover to each bleed screw.

Sectional bleed requirements

Red pipe line (No. 1 system)

Any pipe disturbed between the inboard hydraulic reservoir, front hydraulic pump, accumulator (vertically mounted), upper distribution valve, and the rear suspension struts.

Bleed the complete system i.e. accumulator, deceleration conscious pressure limiting valve, front calipers on the front wheels, upper cylinders on the rear wheel calipers, and the rear suspension struts.

Orange pipe line (No. 2 system)

Any pipe disturbed between the outboard hydraulic reservoir, rear hydraulic pump, accumulator (horizontally mounted), lower distribution valve, and the pressure switch.

Bleed the complete system i.e. accumulator, rear calipers on the front wheels, lower cylinders on the rear wheel calipers, and the pressure switch.

Blue pipe line (No. 1 system)

Any pipe disturbed between the upper brake distribution valve and front calipers on the front wheels and the upper cylinders on the rear wheel calipers.

Bleed the deceleration conscious pressure limiting valve, the front calipers on the front wheels, and the upper cylinder on the rear wheel calipers.

Mauve pipe line (No. 2 system)

Any pipe disturbed between the lower brake distribution valve and rear calipers on the front wheel and lower cylinder on the rear wheel calipers.

Bleed the rear calipers on the front wheels and the lower cylinders on the rear wheel calipers.

Checking the levels in the hydraulic reservoirs

After bleeding, the following procedure should be used when checking the levels in the hydraulic reservoirs.

1. Switch on the ignition.
2. Depressurize the system by using the bleed screws on both hydraulic accumulators until both brake pressure warning panels are illuminated.
3. Start the engine and allow to run at tick over.
4. Disconnect the lower ends of the levelling valve links and lift simultaneously approximately 38 mm (1.50 in). Hold in this position and allow the height to stabilize (this takes approximately 30 seconds).
5. Reconnect the levelling valve links and allow the car to level (this takes approximately 30 seconds).
6. Allow the engine to run for a further four minutes.
7. Check the levels in each reservoir, adjust to the FULL mark if required. Do not overfill the reservoir.
8. Switch off the engine.
9. Seal the reservoirs as described in Section G5/1-1.



WARNING

Use only Hydraulic System Mineral Oil (LHM) to replenish the braking and levelling systems.

Do not use Brake Fluids (Castrol RR363, Universal, or any other type). The use of any type of brake fluid, even in very small amounts, will cause component failure necessitating extensive rectification to the braking and levelling systems of the car.

Always ensure before fitting any seals, hoses, pipes, etc. that they are suitable for a mineral oil system. For details of correct component identification reference should be made to Chapter G of the Workshop Manual.

Always ensure that a sealed container of Hydraulic System Mineral Oil (LHM) is fitted adjacent to the battery.

Always ensure that no foreign matter enters the systems when work is being carried out.

Introduction

The two hydraulic mineral oil reservoirs are situated on the left-hand valance of the engine compartment. Mineral oil for System 1 is contained in the inboard reservoir and for System 2 in the outboard reservoir.

The reservoirs are made from a translucent material to enable the level and colour of the mineral oil to be seen. To indicate a low mineral oil level, each reservoir contains a float actuated reed switch. This switch will cause a facia warning lamp to illuminate should the mineral oil in the reservoir fall below a pre-set level.

Three types of filler cap arrangements have been fitted to the reservoirs. The original arrangements did not contain any type of sealing arrangement. The second (see fig. G5-1) incorporated a sealing arrangement which consisted of wiring the filler caps and applying a lead seal to the ends of the wire. The latest arrangement (see fig. G5-2) incorporates a reservoir filler device. This device consists of a spring loaded ball valve. The valve is opened by the filler nozzle of a purpose designed container of new hydraulic system mineral oil (LHM). The filler nozzle when inserted into the reservoir filler device, can be locked into position thus allowing the container to be tipped during filling.

With the introduction of this latest arrangement, two of the purpose designed containers, each containing 500 ml (17.5 fl oz) of mineral oil, are supplied with each new car. These containers are

Hydraulic mineral oil reservoirs

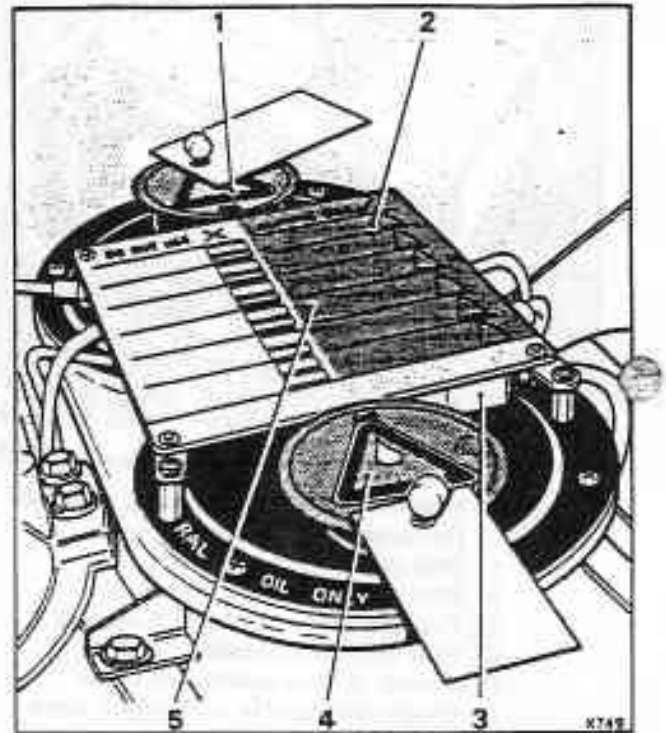

Fig. G5-1 Hydraulic system mineral oil reservoir

- 1 Filler cap (No. 1 system)
- 2 Multi-lingual instruction plate
- 3 Pipe connection block (No. 2 system)
- 4 Filler cap (No. 2 system)
- 5 Mineral oil level switch connection (hidden beneath the multi-lingual plate)

located within the luggage compartment adjacent to the battery (see fig. G5-3). Before returning the car to a customer always ensure that two new containers are supplied.

Important

Do not refill or re-use an empty container.

If a car has one of the early type arrangements fitted it is possible to modify it to the latest arrangement as described under the heading, **Modification to the hydraulic reservoir filler caps.**

Providing that the correct precautions are taken against the ingress of dirt into the systems and that perfectly clean hydraulic system mineral oil is always used when topping-up, the reservoirs will only require servicing at the intervals specified in the Service Schedule Manual publication number TSD 4406.

After topping-up the reservoir or after changing the mineral oil in the system, ensure that all warning labels and the appropriate tamperproofing methods are applied to the reservoirs.

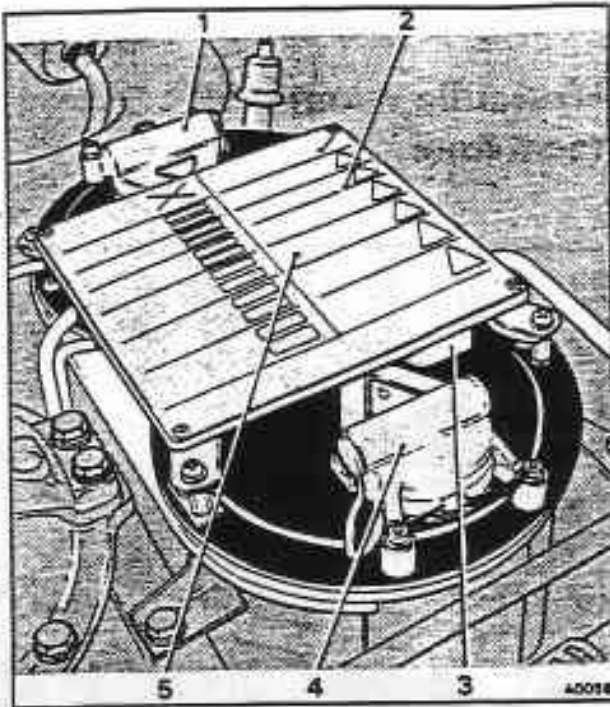

Fig. G5-2 Hydraulic system mineral oil reservoir (horizontal filler cap)

- 1 Filler cap (No 1 system)
- 2 Multi-lingual instruction plate
- 3 Pipe connection block (No 2 system)
- 4 Filler cap (No 2 system)
- 5 Mineral oil level switch connection (hidden beneath the multi-lingual plate)



Fig. G5-3 Hydraulic system mineral oil refill bottle with special nozzle location

A

DO NOT USE	ALWAYS USE
Do not use RR363, Universal, or any other brake fluid.	Use only Hydraulic System Mineral Oil (LHM) from special container. Spars container in vaggio compartment.
Ne pas utiliser RR363, Universal, ou tout autre liquide pour freins.	Utiliser seulement de l'huile minérale pour système hydraulique (LHM) provenant d'un contenant spécial. Conteneur de réserve dans le coffre à bagages.
Es dürfen keine RR363, Universal oder andere Bremsflüssigkeiten verwendet werden.	Nur Mineralöl (LHM) für Hydrauliksystem aus dem Spezialbehälter verwenden. Ersatzbehälter im Gepäckraum.
Non usare fluido per freni RR363, Universal o di altro tipo.	Usare solo olio minerale per impianti idraulici (LHM) del contenitore speciale. Contenitore di scorta nella bagagliaia.
No use RR363, Universal or cualquier otro líquido para frenos.	Usar solamente aceite mineral para sistema hidráulico (LHM) del recipiente especial. Se incluye recipiente de reserva en el compartimiento.
لا تستخدم أو ادر ٣٦٣ أو بونيفرنس أو أي سائل آخر للفرميل	استخدم فقط زيت معدني للنظام الهيدروليكي (LHM) من الحاوية الخاصة. الحاوية الاحتياطية موجودة في قسم البضائع

WARNING. CLEAN FILLER PLUG BEFORE REMOVING. USE ONLY HYDRAULIC SYSTEM MINERAL OIL FROM SEALED CONTAINER.

B

ACHTUNG: NUR HYDRAULIKÖL MINERAL (LHM) NACHFÜLLEN.

ATTENTION: UTILISEZ SEULEMENT LIQUIDE HYDRAULIQUE MINERAL (LHM).

ATTENZIONE: USARE SOLO FLUIDO A BASE MINERALE PER L'IMPIANTO IDRAULICO (LHM).

ATENCIÓN: USE SOLAMENTE ACEITE MINERAL HIDRÁULICO (LHM).

استعمل فقط زيت معدني
للنظام الهيدروليكي

Fig. G5-4 Hydraulic system mineral oil multi-lingual warning labels
 A Large type multi-lingual warning label B Small type black multi-lingual warning label

Modification to the hydraulic reservoir filler cap
 To incorporate this modification a kit of parts is required, obtained from Rolls-Royce Motors Limited. Three different kits are available, dependent upon the original arrangement fitted.

On cars fitted with the large type multi-lingual warning label (see fig. G5-4, A) conversion kit RH 2886 GMF is applicable.

On cars (excluding Corniche) fitted with the smaller black multi-lingual warning label (see fig. G5-4, B) conversion kit RH 2889 GMF is applicable.

On Corniche cars fitted with the smaller black multi-lingual warning label conversion kit RH 2890 GMF is applicable.

1. Unscrew and remove the multi-lingual warning label (see fig. G5-4).
2. Remove the reservoir cover and screws, two from each reservoir.
3. Remove and discard the green filler caps, plastic warning labels, and fluid filters (see fig. G5-5).
4. Fit the replacement sealing washers and filler caps (see fig. G5-6).
5. Firmly secure the new filler caps using socket headed capscrews and locking plates.
6. Fit new security seals (see fig. G5-7).
7. On cars originally fitted with the larger multi-lingual label (see fig. G5-4, A) replace the label.
8. On cars fitted with the smaller black multi-lingual warning label (see fig. G5-4, B) carry out operations 9 to 13 inclusive.
9. Mark the reservoir tops prior to drilling fixing holes for the stand-off pillars.

Use the spacer plate provided in the fitting conversion kit as a template to ensure accurate positioning of the holes.

10. Drill three holes 4,8 mm (0.187 in) diameter holes through the reservoir assembly and fit the stand-off pillars as shown in figure G5-8, A, B, and C.
11. Drill one 8 mm (0.312 in) diameter hole in the reservoir lid (see fig. G5-8 inset D).
12. Screw the stand-off pillar D to the spacer plate and attach to the reservoir top.
13. Fit the new multi-lingual label to the stand-off pillars (see figs. G5-8 and G5-9).

Hydraulic mineral oil reservoir - To remove (refer to figs. G5-1, G5-2, and G5-10)

The reservoirs can be removed individually from their support bracket.

1. Depressurize the hydraulic systems as described in Section G2.
2. Disconnect the battery.
3. Remove the multi-lingual instruction plate from the top of the reservoirs.
4. Disconnect the Lucar connector from the top of the reservoir.
5. Remove tamperproofing components to allow the filler cap to be removed.
6. Remove the capscrews, filler caps, filler neck plugs, and warning labels where fitted.

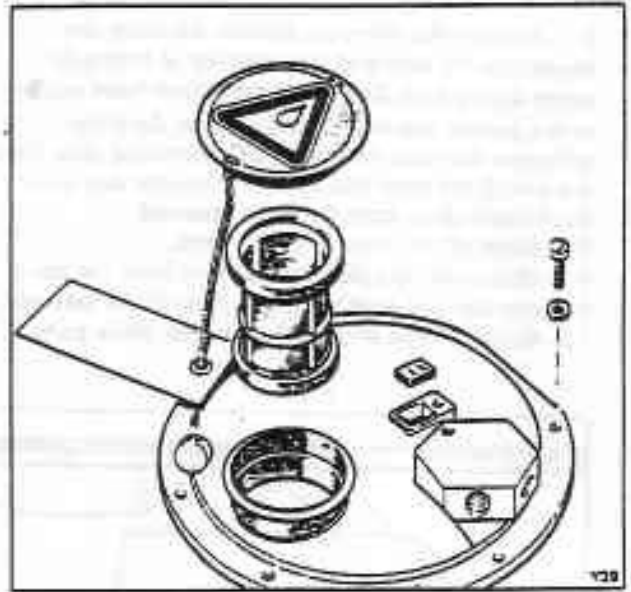

Fig. G5-5 Hydraulic system mineral oil filler neck, filter, and label

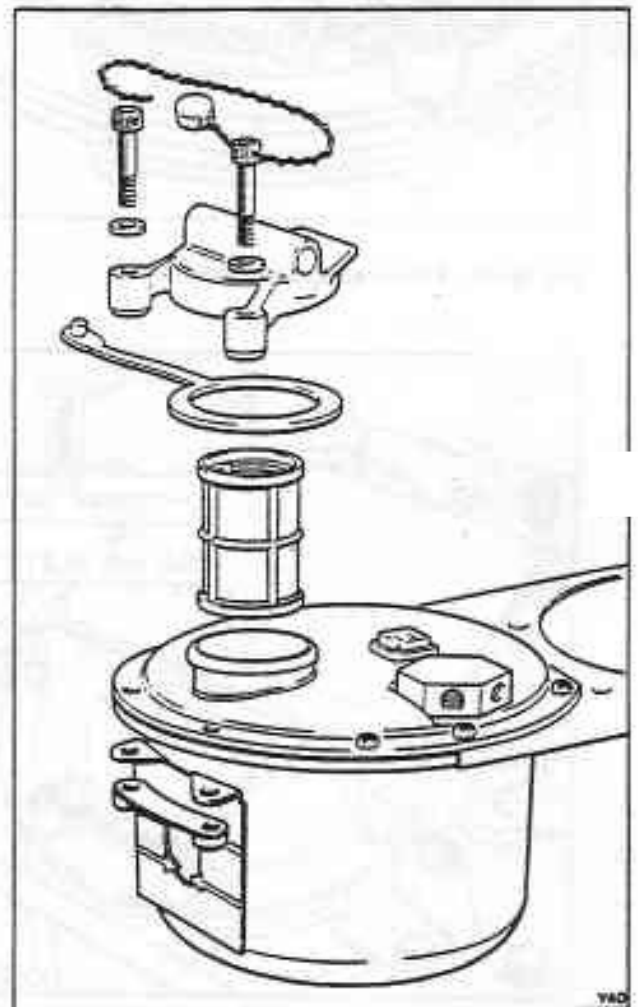

Fig. G5-6 Hydraulic system mineral oil filler neck and locking device

7. To drain the reservoir, slacken the hose clip situated in the centre of the reservoir to hydraulic pump supply pipe. Compress the rubber hose section of the pipe to prevent mineral oil flow. Carefully withdraw the hose off the metal connecting pipe. Place the end of the hose into a clean container and allow the mineral oil to drain from the reservoir.
8. Blank off the hose and pipe ends.
9. Disconnect the pipe connections from the top of the reservoir and ease the pipes clear of the reservoir.
10. Blank off pipe ends and connector block ports.

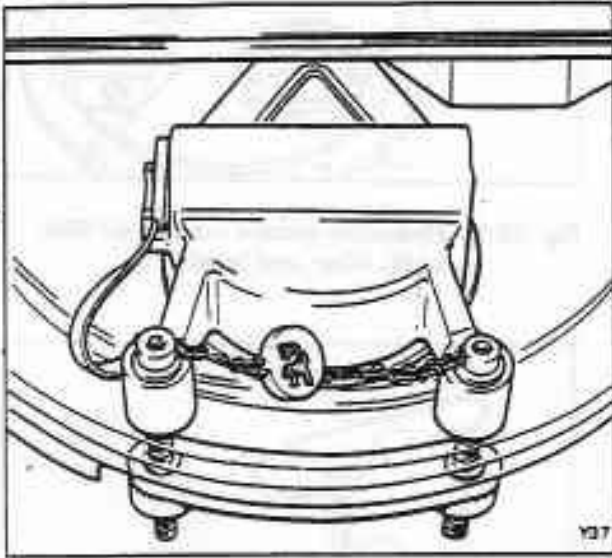

Fig. G5-7 Filler cap security sealing

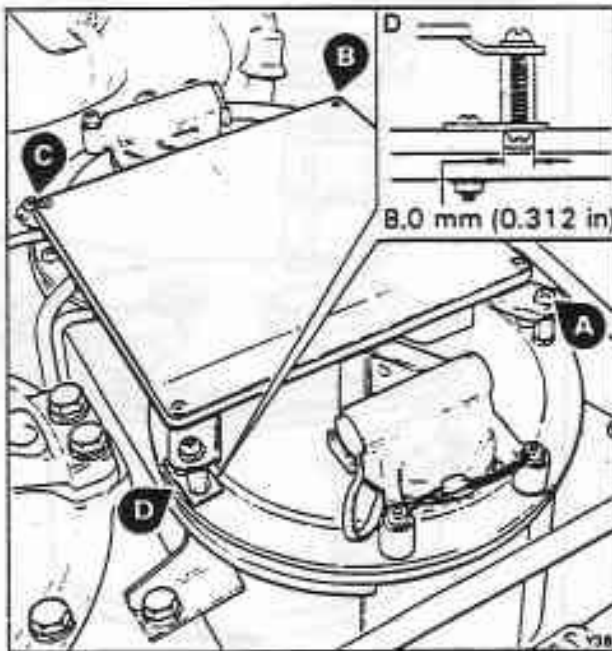

Fig. G5-8 Hydraulic system mineral oil reservoir conversion (All cars other than Corniche)

11. Remove the small retaining screws from the top flange of the reservoirs.
12. Lift the reservoir from the mounting bracket.
13. If necessary, repeat the Operations to remove the remaining reservoir.

Reservoir - To dismantle, clean, and assemble (refer to fig. G5-11)

1. Drain and remove the reservoir as described under Hydraulic mineral oil reservoir - To remove.
2. Remove the screws securing the lid and gently prise off, taking care not to damage either faces. Remove the seal ring if fitted and discard.
3. Remove the sealant from both lid and reservoir joint faces. Care must be taken to ensure that small pieces of sealant are not left encroaching around the screw holes.
4. Remove the screws securing the reed switch and float assembly to the underside of the reservoir lid. Ensure that no foreign matter adheres to the magnet on the reed switch float.
5. Remove the reservoir filler neck filter/baffle.
6. Using a suitable broad ended screwdriver placed between the bottom of the reservoir and the outlet filter, carefully ease the filter off its snap-on connection neck.

Note

When removing the inlet filter/baffle and outlet filter, care should be taken to ensure that the fine mesh of the filters is not torn or damaged.

Care must also be taken during dismantling and cleaning to ensure that the reed switch stem is not bent or damaged, as this will cause the switch to be inoperative.

7. Thoroughly clean all parts with Genklene or methylated spirits, drying them with dry compressed air. Ensure that all holes and adapter threads are carefully cleaned and have blanks fitted.
8. Assemble the reservoir by reversing the dismantling procedure noting the following.
9. Using sealant RRG2/139 apply an unbroken bead of sealant approximately 4 mm (0.156 in) diameter around the reservoir bowl.

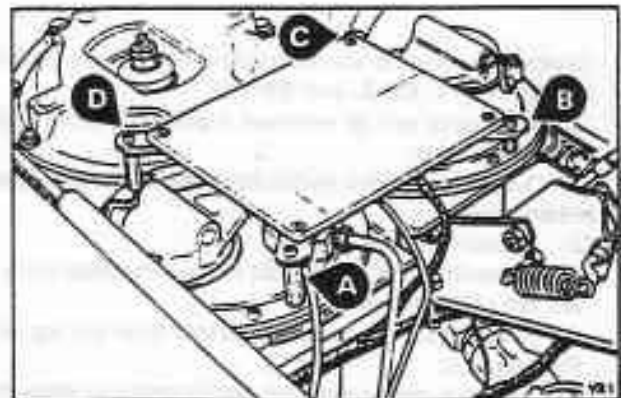

Fig. G5-9 Hydraulic system mineral oil reservoir conversion (Corniche only)

10. Immediately after applying the sealant, fit the reservoir lid and secure with the screws. Torque tighten in accordance with the figures quoted in Section G19.
11. Remove the reservoir filler cap and filter/baffle. Check that no sealant has been extruded over the lip of the bowl and dropped into the interior of the reservoir. If this happens the reservoir lid should be removed as described in Operations 2 and 3.
12. Allow the sealant to cure for a minimum of six hours and then cut off any excess sealant from the edge of the joint with a sharp knife.

Reservoir - To fit and top-up

Fit the reservoir by reversing the procedure given for removal noting the following.

1. When the reservoir has been fitted ensure that all pipes are connected and torque tightened (see Section G19).
2. If the reservoirs incorporate the latest filler arrangement as shown in figure G5-8, fit the filler cap, security seals (ensuring that new locking wire and lead seals are used), and warning labels.
3. Fill the reservoir with clean hydraulic system mineral oil (see Chapter D) until the level in the reservoir is slightly above the topping-up mark on the level indication plate.
4. Run the engine for approximately four minutes with the car unladen, then top-up the reservoir to the correct level. Never allow the mineral oil level to fall below the minimum level.
5. Check for leaks especially around all unions and pipes which have been disturbed.
6. The hydraulic system(s) must then be bled completely as described in Section G4.

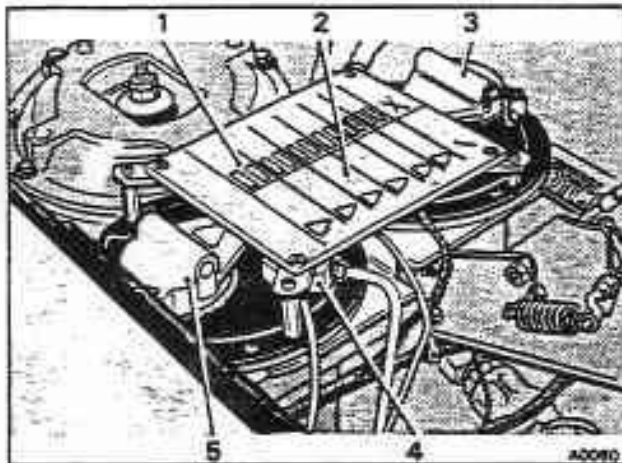

Fig. G5-10 Hydraulic system mineral oil reservoir (Corniche cars)

- 1 Multi-lingual instruction plate
- 2 Mineral oil level switch connection (hidden beneath the multi-lingual plate)
- 3 Filler cap (No. 1 system)
- 4 Pipe connection block (No. 2 system)
- 5 Filler cap (No. 2 system)

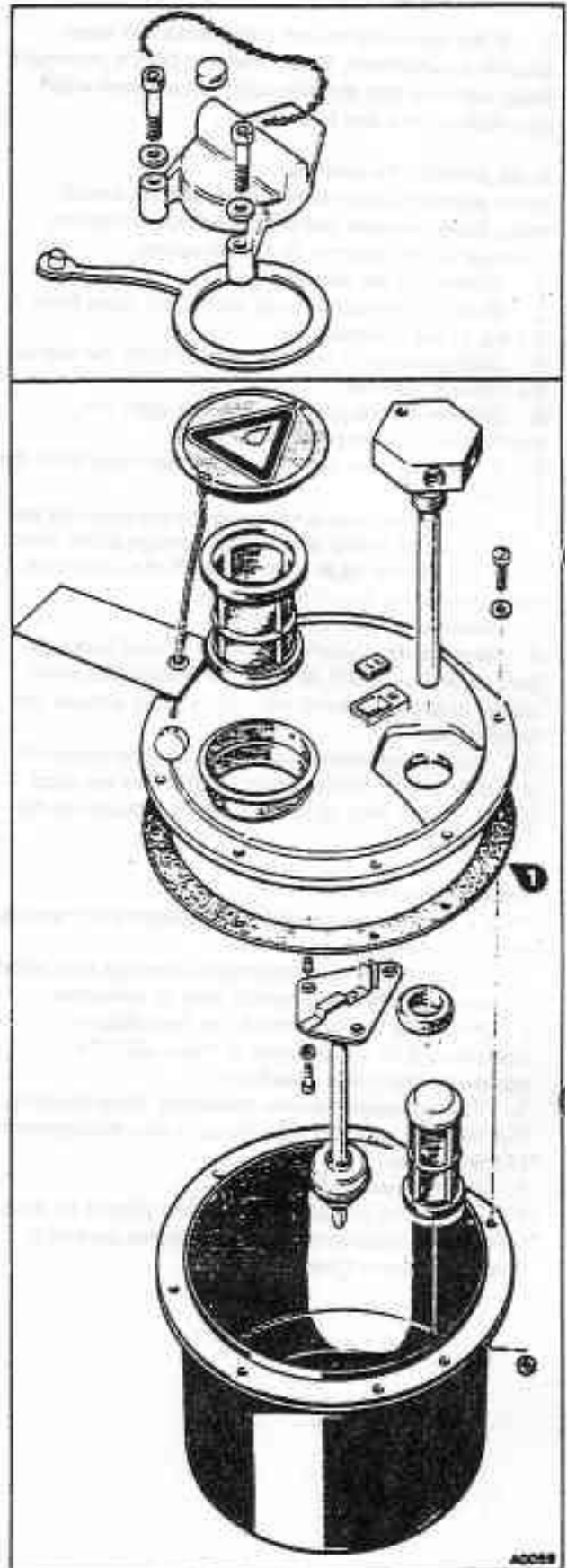

Fig. G5-11 Hydraulic system mineral oil reservoir (Inset showing horizontal filler cap)

- 1 Seal ring (fitted to early cars)

7. If the reservoirs do not incorporate the latest security arrangement, fit any security device previously fitted ensuring that the filler caps are secured with new locking wire and lead seals.

Reed switch - To remove

In the event of a low mineral oil level reed switch being faulty, renewal can be carried out as follows. Drainage of the reservoir is not necessary.

1. Disconnect the battery.
2. Remove the multi-lingual instruction plate from the top of the reservoirs.
3. Disconnect the Lucar connection from the top of the relevant reservoir.
4. Disconnect the pipe connections from the manifold block on top of the reservoir.
5. If fitted, remove the security arrangement from the filler cap.
6. Remove the screws securing the reservoir lid and gently prise off taking care not to damage either face. Allow the mineral oil to drain from off the underside before removing the lid completely.
7. Remove the seal ring if fitted.
8. Remove the sealant from both lid and reservoir joint faces. Care must be taken to ensure that small pieces of sealant are not left encroaching around the screw holes.
9. Remove the screws retaining the reed switch to the underside of the reservoir lid. Remove the reed switch. Ensure that no foreign matter adheres to the float magnet.

Reed switch - To fit

To fit a reed switch, reverse the procedure for removal noting the following.

1. All parts should be thoroughly cleaned with either Genklene or methylated spirits prior to assembly.
2. Assemble the reservoir lid as described in Operations 9 to 12 inclusive of Reservoir - To dismantle, clean, and assemble.
3. Fit any security device previously fitted ensuring that the filler caps are secured with new locking wire and lead seals.
4. Fit the warning labels.
5. All screws and pipe connections should be torque tightened in accordance with the figures quoted in Section G19 and Chapter P.



WARNING

Use only Hydraulic System Mineral Oil (LHM) to replenish the braking and levelling systems.

Do not use Brake Fluids (Castrol RR363, Universal, or any other type). The use of any other type of brake fluid, even in very small amounts, will cause component failure necessitating extensive rectification to the braking and levelling systems of the car.

Always ensure before fitting any seals, hoses, pipes, etc., that they are suitable for a mineral oil system. For details of correct component identification reference should be made to Chapter G of the Workshop Manual.

Always ensure that a sealed container(s) of Hydraulic System Mineral Oil (LHM) is fitted adjacent to the battery.

Always ensure that no foreign matter enters the systems when work is being carried out.

Introduction

The two hydraulic mineral oil reservoirs are situated on the left-hand valance of the engine compartment. Mineral oil for System 1 is contained in the inboard reservoir and for System 2 in the outboard reservoir.

The reservoirs (the inboard reservoir is larger than the outboard reservoir) are made from a translucent material to enable the level and colour of the mineral oil to be seen. To indicate a low mineral oil level, each reservoir contains a float actuated reed switch. This switch will cause a facia warning lamp to illuminate should the mineral oil in the reservoir fall below a pre-set level.

The filler cap incorporates a reservoir filler device. This device consists of a spring loaded ball valve. The valve is opened by the filler nozzle of a purpose designed container of new hydraulic system mineral oil (LHM). The filler nozzle when inserted into the reservoir filler device, can be locked into position thus allowing the container to be tipped during filling.

Two purpose designed containers to suit the filling cap arrangement are supplied with each new car. Each container contains 500 ml (17.5 fl oz) of mineral oil. These containers are located within the luggage compartment adjacent to the battery (see fig. G5/1-2). Before returning the car to a customer always ensure that two new containers are supplied.

Important
Do not refill or re-use an empty container.

Hydraulic mineral oil reservoirs

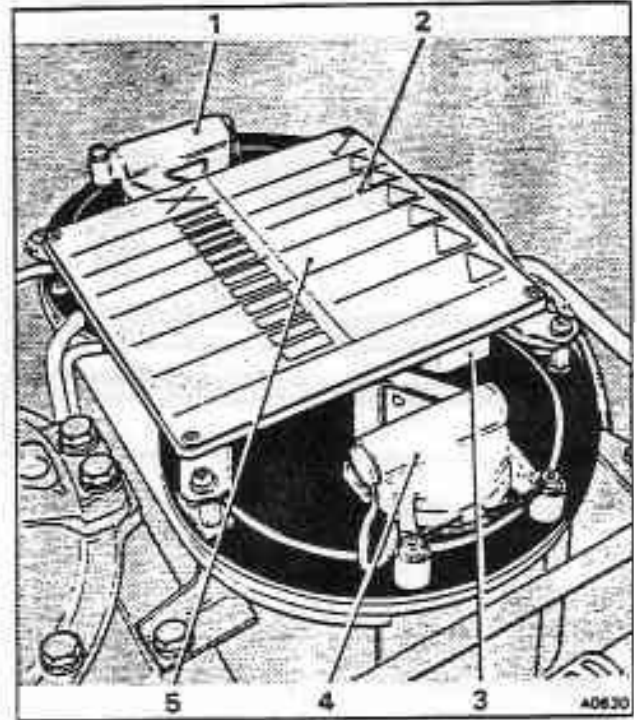

Fig. G5/1-1 Hydraulic system mineral oil reservoir (horizontal filter cap)

- 1 Filler cap (No. 1 system)
- 2 Multi-lingual instruction plate
- 3 Pipe connection block (No. 2 system)
- 4 Filler cap (No. 2 system)
- 5 Mineral oil level switch connection (hidden beneath the multi-lingual plate)

Providing that the correct precautions are taken against the ingress of dirt into the systems and that perfectly clean hydraulic system mineral oil is always used when topping-up, the reservoirs will only require servicing at the intervals specified in the Service Schedule Manual publication number TSD 4406.

After topping-up the reservoir or after changing the mineral oil in the system, ensure that all warning labels and the appropriate tamperproofing method is applied to the reservoirs.

Hydraulic mineral oil reservoir - To remove
Refer to Section G5 for operational procedures when removal of the reservoirs is necessary.

Reservoir - To dismantle, clean, and assemble
Refer to Section G5 for operational procedures when dismantling, cleaning, and assembling of the reservoirs is necessary.

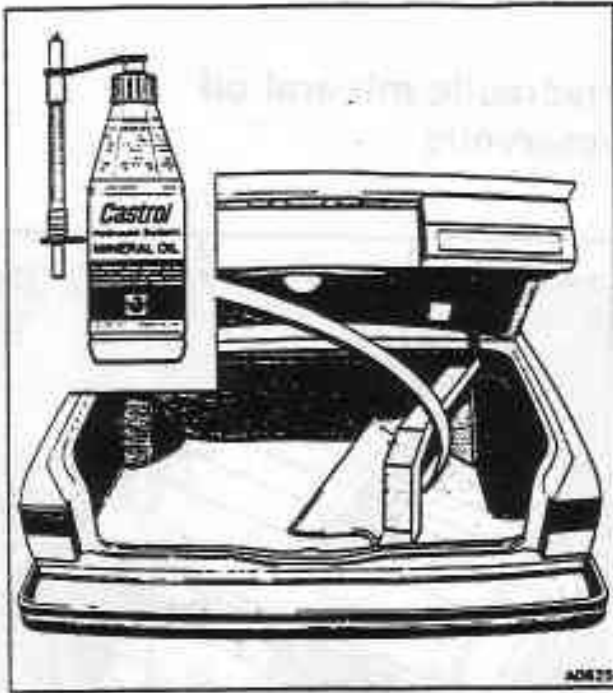

Fig. G5/1-2 Hydraulic system mineral oil refill bottle with special nozzle location

Reservoir - To fit and top-up

Refer to Section G5 for operational procedures when fitting and top-up the reservoirs when necessary.

Reed switch - To remove

Refer to Section G5 for operational procedures when removal of the reed switch is necessary.

Reed switch - To fit

Refer to Section G5 for operation procedures when fitting the reed switch.

Hydraulic pumps

Introduction

The hydraulic pumps used on cars with a mineral oil hydraulic system can be distinguished from those used on conventional brake fluid systems, in that each pump has either a green disc fitted beneath the top adapter or a band of green paint around the staked area (see figs. G6-1, G6-4, and G6-5).

Internally the pump has a larger diameter plunger than the pumps using RR363 brake fluid. Also, the seals are made of material that meets mineral oil requirements.

The brake pump push rod has a collapsible section of increased diameter; the top edge of the push rod being chamfered for identification (see fig. G6-1).

Never fit a brake pump push rod from a conventional (RR363) brake fluid system as a replacement.

When overhauling a mineral oil brake pump always ensure that sealing rings bearing mineral oil identification marks are fitted (see Section G2).

On cars fitted with the staked type of brake pump the only overhaul possible is the replacement of the two 'O' rings located on the external diameter of the pump body.

Hydraulic pump housing sealing rings - To renew (see figs. G6-3, G6-4, and G6-5)

If hydraulic system mineral oil leakage occurs from a brake pump housing, it is possible, to renew the two sealing rings with the pump in position.

1. Depressurize the hydraulic systems as described in Sections G2 and G2/1.
2. Ensure that the pump and the surrounding area is thoroughly clean.
3. Compress the rubber hose section of the hydraulic pump low pressure inlet pipe to prevent mineral oil flow. Remove the hose from the pump inlet stub pipe. Suitably blank the hose end.
4. To gain access to the front hydraulic pump on cars fitted with an exhaust emission control system, the three-way connector and check valve must be removed (see Chapter U).
5. Disconnect the high pressure outlet and low pressure inlet pipes from the hydraulic pumps.
6. Remove the circlip from the top of the pump, withdraw the outer housing upwards and off the pump.
7. Discard the two sealing rings. Fit new rings lubricated with clean hydraulic system mineral oil of the approved type.
8. Fit the pump outer housing with care, aligning the

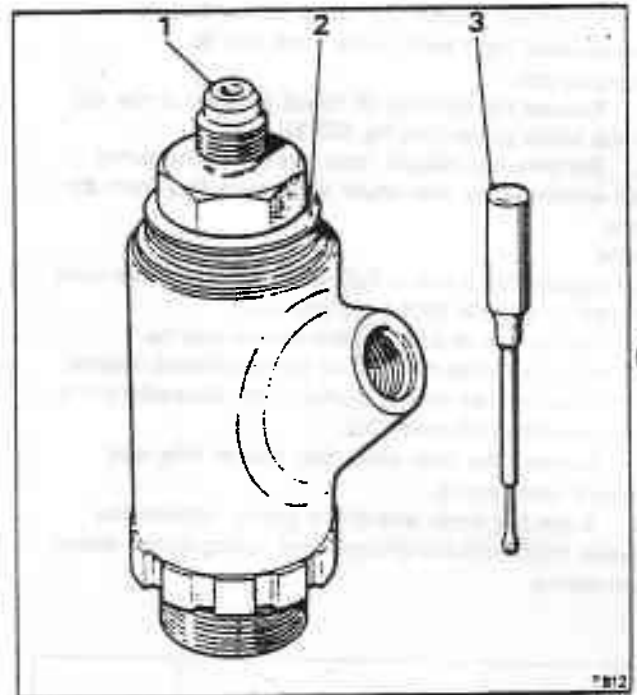

Fig. G6-1 Mineral oil hydraulic pump identification features

- 1 Smaller pipe connection
- 2 Green disc
- 3 Chamfered end face - Push rod

port with the inlet pipe on cars where the hydraulic pump is in position. Press the housing firmly into position, then fit the circlip.

9. Prime the pump with an approved hydraulic system mineral oil. Connect the low pressure feed and high pressure outlet pipe to the pump.
10. On cars fitted with an exhaust emission control system, assemble the three-way connector, and the check valve as described in Chapter U.
11. Top-up the reservoir(s) with an approved hydraulic system mineral oil (see Chapter D). Bleed the hydraulic systems as described in Sections G4 and G4/1.

Hydraulic pump - To remove

1. Carry out Operations 1 to 6 inclusive of, Hydraulic pump housing sealing rings - To renew. These operations also apply to the staked type of pump.
2. Using the special box spanner RH 8428, unscrew and remove the pump from its pedestal on the tappet chest cover. Blank off the pedestal against the ingress of dirt.

Note

The pump must not be removed by using the top adapter as a spanning point.

Hydraulic pump - To dismantle

The following procedures apply to the type of pump fitted with a top adapter (see fig. G6-3 and G6-5) and not the staked type of pump.

When two pumps are being dismantled the components from each pump must not be interchanged.

1. Release the lock-nut (if fitted) situated at the top of the brake pump (see fig. G6-5).
2. Remove the adapter from the top of the pump and withdraw the non-return valve assembly from the bore.

Note

For adapter fitted with a lock-nut special removal tools RH 9813 and RH 9844 are required.

Gentle use of a small screwdriver may be necessary to assist removal of the chamfered washer. If the washer has spread it should be discarded and a new one fitted on assembly.

3. Remove the inlet valve ring, spacer ring, and conical valve spring.
4. From the lower end of the pump, remove the circlip. Withdraw the plunger and spring collar; collect the spring.

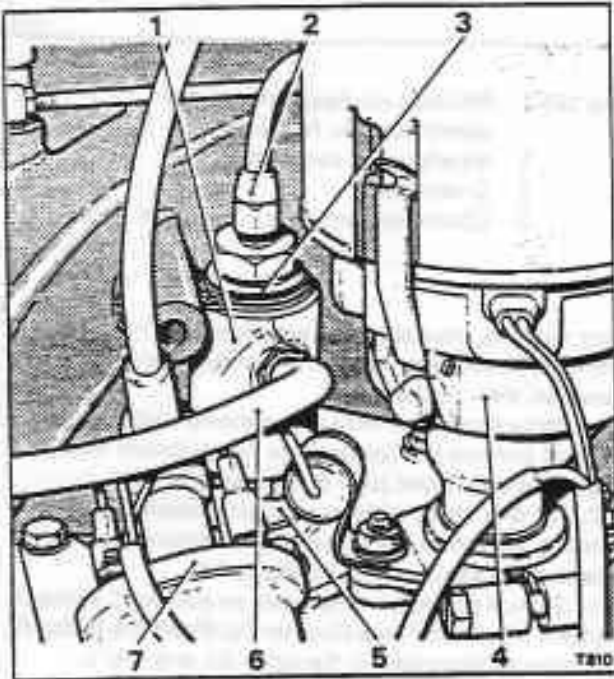

Fig. G6-2 Rear hydraulic pump (No. 2 system)

- 1 Pump outer housing
- 2 High pressure outlet pipe
- 3 Green identification disc
- 4 Ignition distributor
- 5 Pump mounting pedestal
- 6 Low pressure inlet pipe
- 7 Ignition coil

5. Carefully withdraw the plunger barrel from the pump body.

Note

The barrel and plunger are matched ground components and are not interchangeable.

6. Remove and discard the three 'O' rings from the pump body.
7. To dismantle the non-return valve assembly, remove the circlip, push out the valve from the outer body and collect the spring, end stop, and valve.

Hydraulic pump components - To clean and inspect**Important**

All components must be absolutely clean.

Ensure that all tapped holes are free from foreign matter and slivers of thread which might break off during assembly and become entrapped in the hydraulic system. One method of achieving this is to screw slave adapters or setscrews down the threads before thoroughly cleaning the components in Genkline or methylated spirits, and drying with dry compressed air, not with any type of cloth.

It is important that the seating of the valves is correct and that the finely machined barrel and plunger are not scored or damaged.

Under normal circumstances after a thorough cleaning and the introduction of a new set of sealing rings, the only parts that might need renewal are the small coil springs.

Hydraulic pump - To assemble (refer to figs. G6-3 and G6-5)

Ensure that all sealing rings being used are for use with hydraulic system mineral oil.

1. Lubricate all parts including sealing rings with an approved hydraulic system mineral oil (see Chapter D) prior to fitting in their respective positions.
2. Fit the small 'O' ring into position in the centre bore of the pump body.
3. Insert the plunger barrel into the pump body, pressing it through the sealing ring until it abuts the shoulder.
4. Insert and locate the spacer; fit the valve spring (crowned face towards the inlet valve) and the inlet valve into position adjacent to the barrel head. Ensure that the seating face of the valve is free from damage marks, otherwise the efficiency of the pump will be reduced.
5. Assemble the non-return valve, reversing the procedure given for dismantling. Ensure that the valve is fully seated and the circlip correctly located in its groove. The end stop should be drawn upwards to abut the circlip.
6. Fit the non-return valve assembly, larger diameter leading into the pump body bore to the inlet valve ring.
7. Fit the chamfered sealing ring, small bore diameter leading into the pump body bore to abut the shoulder to the non-return valve.
8. Fit the adapter identification disc, and lock-nut (if fitted) to the top of the pump body. Torque tighten the adapter to the figures quoted in Section G19. Special

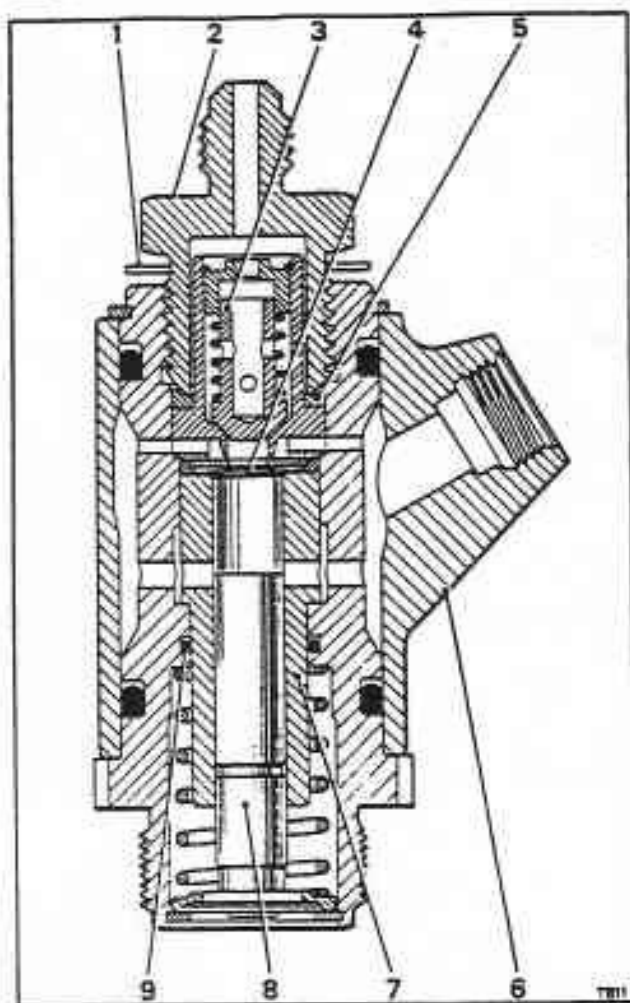

Fig. G6-3 Hydraulic pump

- 1 Identification disc
- 2 Adapter - high pressure outlet
- 3 Non-return valve
- 4 Inlet valve
- 5 Chamfered ring
- 6 Outer housing
- 7 Pump barrel
- 8 Plunger
- 9 Sealing ring

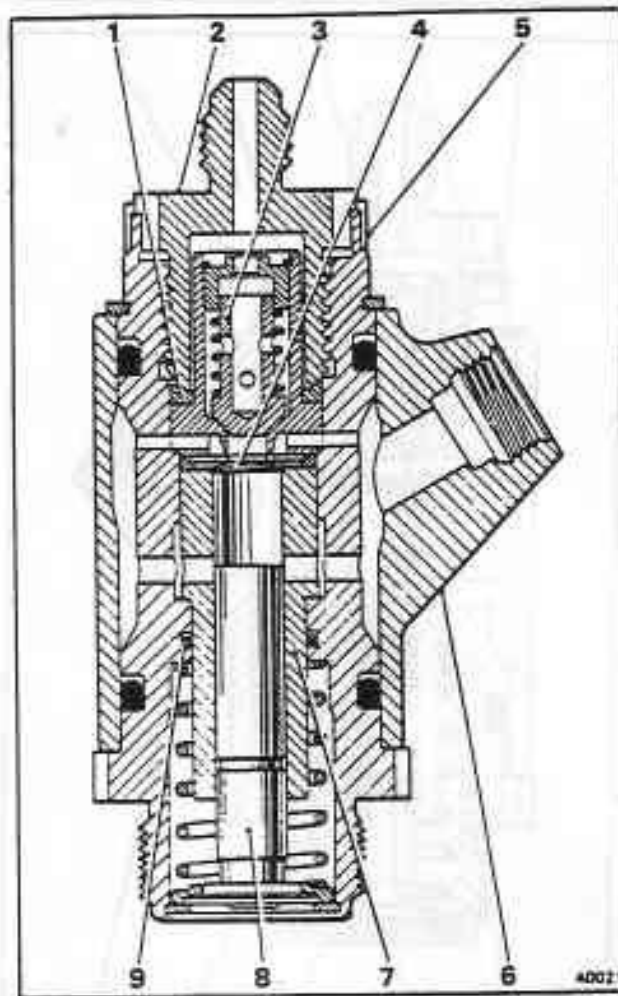

Fig. G6-4 Hydraulic pump (staked)

- 1 Chamfered ring
- 2 Adapter - high pressure outlet
- 3 Non-return valve
- 4 Inlet valve
- 5 Identification (band of green paint)
- 6 Outer housing
- 7 Pump barrel
- 8 Plunger
- 9 Sealing ring

- tools are required for the adapter and lock-nut, RH 9813 and RH 9844. Blank off the adapter.
9. Fit the coil spring into the lower end of the pump body.
 10. Fit the spring collar to the barrel plunger and carefully insert the plunger into the bore of the barrel.
 11. Depress the plunger against the spring sufficiently to enable the circlip to be fitted into its location.
 12. Fit the two 'O' rings to the outside of the pump body.
 13. Fit the pump outer housing with care. Press the housing firmly into position, then fit the circlip.

Hydraulic pump - To fit

To fit the pumps to the tappet cover reverse procedure

given for removal noting the following.

1. Using the special box spanner RH 8428 torque tighten the pumps to the figures given in Section G19.

Note

The top adapter should never be used as a spanning point.

2. Bleed the hydraulic systems as described in Sections G4 and G4/1. Check all disturbed pipe connections for leaks.

Hydraulic pumps - To test (on the car)

1. Depressurize the system as described in Sections G2 and G2/1.
2. Disconnect the accumulator to reservoir return pipe at the manifold on top of the respective reservoir.

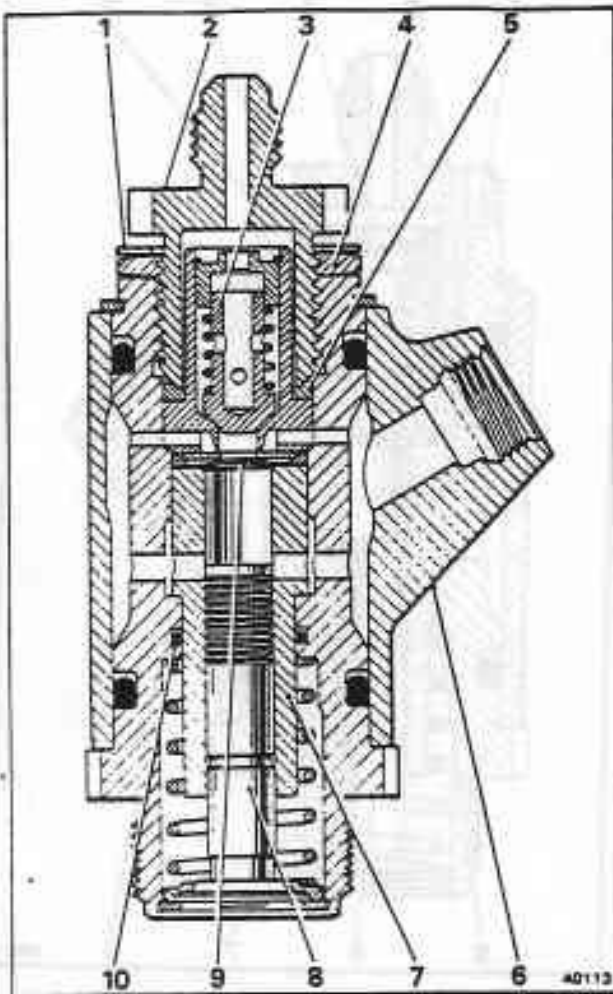

Fig. G6-5 Hydraulic pump

- 1 Identification disc
- 2 Adapter - high pressure outlet
- 3 Non-return valve
- 4 Lock-nut
- 5 Chamfered ring
- 6 Outer housing
- 7 Pump barrel
- 8 Plunger
- 9 Inlet valve
- 10 Sealing ring

Attach a bleed tube onto the end of the pipe and secure the other end of the tube in a clean measuring vessel.

3. Open the bleed screw on the accumulator which is supplied by the brake pump being checked.
4. Ensure that the appropriate reservoir is full and start the engine.
5. Hydraulic system mineral oil should flow from the bleed tube in a series of spurts, coinciding with each revolution of the camshaft. The rate of flow should be approximately 300 ml per minute at an engine speed of 1000 rev/min.
6. If hydraulic system mineral oil does not flow or the pumped quantity is below requirements, the pump should be removed and overhauled.

Hydraulic accumulators

Introduction

The hydraulic accumulators on Silver Spirit, Silver Spur, Bentley Mulsanne (excluding Turbo) and Corniche models are mounted at the front of the crankcase on the 'A' bank side of the engine.

On Bentley Mulsanne Turbo models, the accumulators are mounted at the rear of the crankcase on the 'B' bank side of the engine.

The front accumulator which is vertically mounted supplies the No. 1 Hydraulic system, the horizontally mounted rear accumulator supplies the No. 2 Hydraulic system.

Both accumulators have an internal bleed screw incorporated into the valve housing. Bleeding or depressurizing of an accumulator is achieved by slackening the bleed screw (see figs. G7-1 and G7-2) approximately one revolution. This allows the hydraulic system mineral oil to return internally through the valve housing to its respective reservoir.

In the event of an accumulator failure and replacements are necessary, a sphere, accumulator valve assembly, and 'O' rings can be obtained as individual items. Alternatively, a complete accumulator can be obtained.

Prior to despatch from the manufacturer, all spheres are charged to a pressure of between 60 bar and 64 bar (870 lbf/in² and 928 lbf/in²). The charge pressure in bar is stamped on the screw head located at the top of the sphere. Whenever a sphere is found to be below a working pressure of 31 bar (450 lbf/in²) a replacement sphere must be fitted; no attempt should be made to recharge the sphere.

Hydraulic accumulator sphere - To renew whilst in position (see figs. G7-1 and G7-2)

It should be noted that on cars other than the Mulsanne Turbo, to remove the sphere from No. 2 system the sphere from No. 1 system will have to be removed. On Turbo cars to remove No. 2 system sphere, the complete accumulator of No. 1 system will have to be removed, refer to Hydraulic accumulator - To remove.

1. Depressurize the hydraulic system as described in Section G2.
2. Carefully hold the valve body of the accumulator, then using a suitable chain wrench located around the circumference of the sphere, unscrew and remove the sphere from the valve housing. Discard the sealing ring (see fig. G7-3).
3. Locate a new sealing ring lubricated with clean hydraulic system mineral oil into the valve body.
4. Fit the new sphere to the valve body and torque tighten to the figure quoted in Section G19.
5. After fitting the sphere, top-up the reservoir(s) with a recommended hydraulic system mineral oil (see

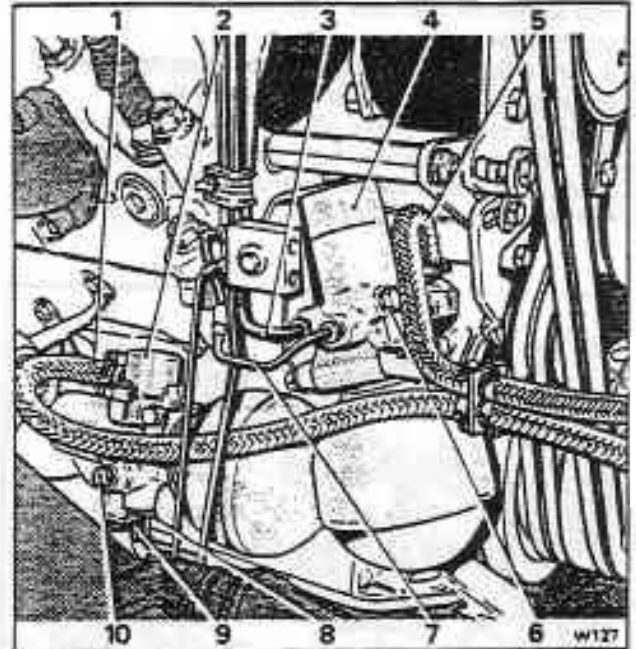

Fig. G7-1 Hydraulic accumulators (excluding Mulsanne Turbo)

- 1 Low pressure return to reservoir
- 2 Accumulator (No. 2 system)
- 3 High pressure inlet from pump
- 4 Accumulator (No. 1 system)
- 5 Low pressure return to reservoir
- 6 Bleed screw
- 7 High pressure outlet to upper distribution valve and right-hand suspension strut
- 8 High pressure inlet from pump
- 9 High pressure outlet to lower distribution valve and left-hand suspension strut
- 10 Bleed screw

Chapter D). With the engine running check for leaks.
6. Test the accumulator(s) as described in Hydraulic accumulator - To test.

7. Bleed the hydraulic system(s) as described in Section G4.

Hydraulic accumulator - To remove

It should be noted that the high pressure pipe connections on the accumulators are of the rubber sleeve type (see Section G3). All pipes and ports should have blanks fitted when disconnected.

1. Depressurize the hydraulic system as described in Section G2.
2. Disconnect the high pressure outlet pipe (orange

or red) from the accumulator and connector block; remove the pipe.

3. Disconnect the high pressure inlet pipe from the accumulator.

Note

On all cars except the Mulsanne Turbo when removing a front accumulator it will be necessary to detach the outlet pipe connector block from its mounting bracket. This allows the inlet pipe to be withdrawn from the accumulator port.

4. Fit a hose clamp to the intermediate hose of the accumulator return pipe to prevent the flow of hydraulic system mineral oil from the reservoir.

5. Unscrew the worm drive clip on the accumulator return pipe connection and withdraw the pipe and hose from the accumulator.

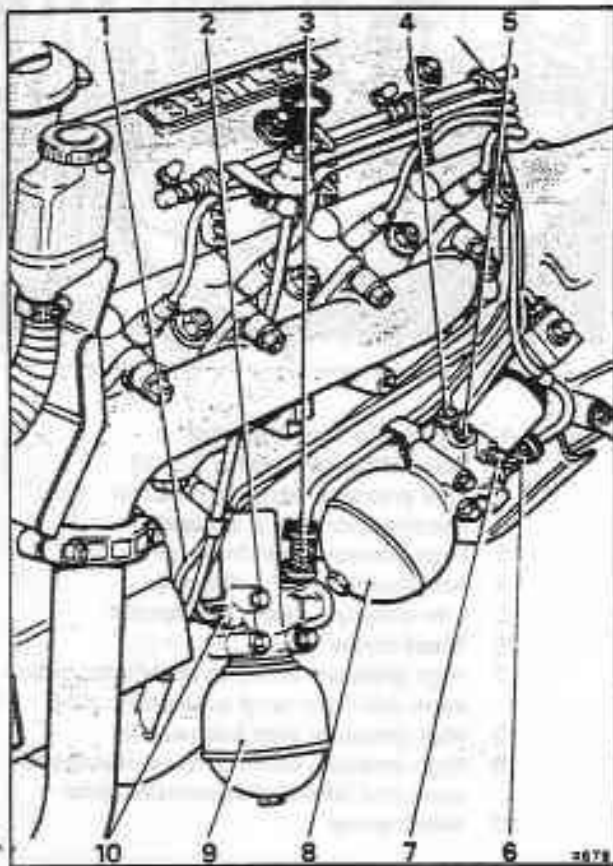

Fig. G7-2 Hydraulic accumulators (Mulsanne Turbo)

- 1 High pressure inlet from pump
- 2 Bleed screw
- 3 Low pressure return to reservoir
- 4 High pressure inlet from pump
- 5 High pressure outlet to lower distribution valve and left-hand suspension strut
- 6 Low pressure return to reservoir
- 7 Bleed screw
- 8 Accumulator (No. 2 system)
- 9 Accumulator (No. 1 system)
- 10 High pressure outlet to upper distribution valve and right-hand suspension strut

6. Remove the setscrew from the mounting bracket at the end of the accumulator.

7. Support the accumulator, then remove the two remaining securing bolts; collect the distance pieces. Lower the accumulator from the engine.

Hydraulic accumulator - To fit

Fit the accumulator to the engine by reversing the procedure given for removal noting the following.

1. When fitting the high pressure pipe connections new rubber sleeves must be fitted to the pipe ends.

For fitting instructions reference should be made to Section G3.

2. All setscrews and pipe connections must be torque tightened in accordance with the figures quoted in Section G19 and Chapter P.

3. After fitting, top-up the reservoir(s) with a recommended hydraulic system mineral oil (see Chapter D). With the engine running leak check all joints and unions which have been disturbed.

4. Test the accumulator as described in Hydraulic accumulator - To test.

5. Bleed the hydraulic system(s) as described in Section G4.

Accumulator valve housing assembly - To dismantle (refer to fig. G7-4)

1. Remove the accumulator as described under Hydraulic accumulator - To remove.

2. Carefully hold the valve housing in a vice. Using a suitable strap spanner located around the circumference of the sphere, unscrew and remove the sphere from the valve housing. Discard the sealing ring (see fig. G7-3).

3. Remove the setscrew securing the connection valve retaining plate (see item 3). Remove the plate and valve ball.

4. Remove the bleed screw and ball (see item 1). Remove and discard the 'O' ring from the bleed screw.

5. Position the valve housing onto a press and depress the spring retaining plug (see item 2) sufficiently to allow the snap ring to be removed.

6. Release the pressure on the retaining plug and remove the plug, adjusting washers (if fitted), spring, and spring retainer. Remove and discard the 'O' ring from the retaining plug.

7. Remove the connection valve (see item 3). The valve can only be removed from the sphere end of the housing.

8. Position the housing onto a press with the cut-out spring housing (see item 4) located under the spindle. Apply sufficient pressure to retain the housing when the retaining screws are removed.

9. Remove the screws and carefully ease off the pressure.

10. Remove the spring housing, adjusting shims (if fitted), spring, spring seating, and the cut-out valve.

The cut-out valve contains a stop ring and can therefore only be removed in the direction of the cut-out chamber. Remove and discard the 'O' ring from the cut-out chamber.

Hydraulic accumulators

Introduction

The hydraulic accumulators are mounted at the rear of the crankcase on the 'B' bank side of the engine.

The front accumulator which is vertically mounted supplies the No. 1 Hydraulic system, the horizontally mounted rear accumulator supplies the No. 2 Hydraulic system.

The low pressure return outlet on the No. 2 system accumulator positionally differs to that of earlier Turbocharged models. The cut-out housing is turned through 180°, the outlet pointing directionally towards the accumulator sphere (see fig. G7/1-1).

Both accumulators have an internal bleed screw incorporated into the valve housing. Bleeding or depressurizing of an accumulator is achieved by slackening the bleed screw (see fig. G7/1-1) approximately one revolution. This allows the hydraulic system mineral oil to return internally through the valve housing to its respective reservoir.

In the event of an accumulator failure and replacements are necessary, a sphere, accumulator valve assembly, and 'O' rings can be obtained as individual items. Alternatively, a complete accumulator can be obtained.

Prior to despatch from the manufacturer, all spheres are charged to a pressure of between 60 bar and 64 bar (870 lbf/in² and 928 lbf/in²). The charge pressure in bar is stamped on the screw head located at the top of the sphere. Whenever a sphere is found to be below a working pressure of 31 bar (450 lbf/in²) a replacement sphere must be fitted; no attempt should be made to recharge the sphere.

Hydraulic accumulator sphere - To renew

To enable the removal of the sphere from the accumulator of No. 2 system, complete removal of the accumulator from the engine is necessary, refer to Hydraulic accumulator - To remove.

1. Depressurize the hydraulic system as described in Section G2/1.
2. Carefully hold the valve body of the No. 1 system whilst in position. Using a suitable chain wrench located around the circumference of the sphere, unscrew and remove the sphere from the valve housing. Discard the sealing ring (see fig. G7-3).
3. Carefully hold the valve body of the accumulator removed from No. 2 system in a vice. Using a suitable chain wrench located around the circumference of the sphere, unscrew and remove the sphere. Discard the sealing ring (see fig. G7-3).
4. Locate a new sealing ring lubricated with clean hydraulic system mineral oil into the valve body.
5. Fit the new sphere to the valve body and torque

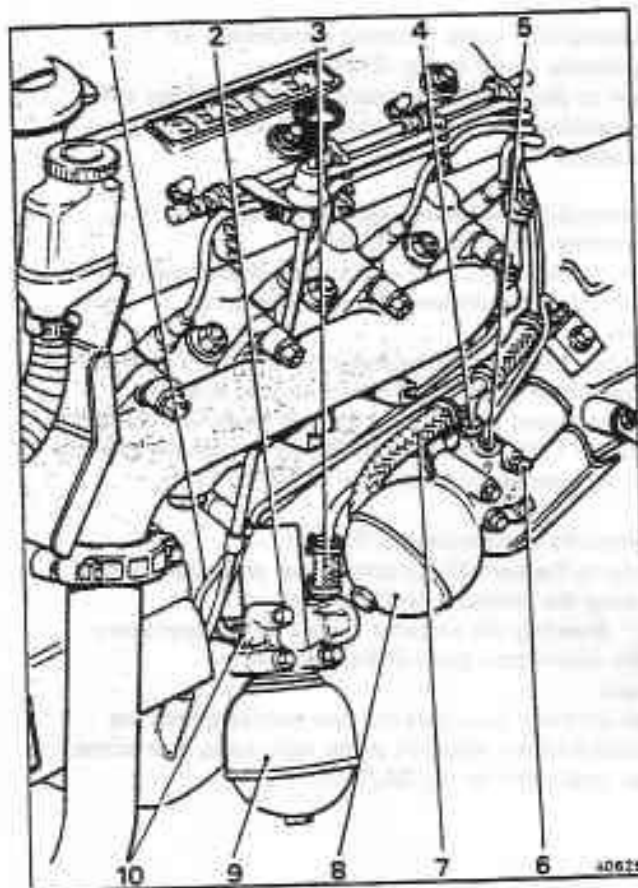

Fig. G7/1-1 Hydraulic accumulators (Turbo R)

- 1 High pressure inlet from pump
- 2 Bleed screw
- 3 Low pressure return to reservoir
- 4 High pressure inlet from pump
- 5 High pressure outlet to low distribution valve and pressure switch
- 6 Bleed screw
- 7 Low pressure return to reservoir
- 8 Accumulator (No. 2 system)
- 9 Accumulator (No. 1 system)
- 10 High pressure outlet to upper distribution valve, left-hand, and right-hand suspension struts

tighten to the figure quoted in Section G19.

6. After fitting the sphere, top-up the reservoir(s) with a recommended hydraulic system mineral oil (see Chapter D). With the engine running, check for leaks.

7. Test the accumulator(s) as described in Hydraulic accumulator - To test.

8. Bleed the hydraulic system(s) as described in Section G4/1-1.

Hydraulic accumulator - To remove

Refer to Section G7 for operational procedures when removal of hydraulic accumulators is necessary.

Hydraulic accumulator - To fit

Refer to Section G7 for operational procedures when fitting of hydraulic accumulators is necessary.

Accumulator valve housing assembly - To dismantle (refer to fig. G7-4)

Refer to Section G7 for operational procedures when dismantling of the accumulator valve housing is necessary.

Accumulator valve housing assembly - To assemble (refer to fig. G7-4)

Refer to Section G7 for operational procedures when assembling the accumulator valve housing.

Note

The low pressure return outlet on the No. 2 system accumulator positionally differs to that of earlier Turbocharged models. The cut-out housing is turned through 180°, the outlet pointing directionally towards the accumulator sphere (refer to fig. G7/1-1).

Hydraulic accumulator - To test

Refer to Section G7 for operational procedures when testing the hydraulic accumulators.

Bleeding the systems should be in accordance with information given in Section G4/1-1.

Note

On left-hand drive cars the two service points are located on the longeron at the right-hand side of the car body (refer to fig. G4/1-1).

11. Thoroughly clean all components with Genklene or methylated spirits. Dry with dry compressed air. Do not use any type of cloth.

Accumulator valve housing assembly - To assemble (refer to fig. G7-4)

During assembly, ensure that all components are handled with care. Also, meticulous care must be taken to ensure that during assembly complete cleanliness is maintained.

1. Fit a new 'O' ring to the bleed screw (see item 1). Inspect the ball and if not damaged (if damaged renew) place the ball onto its seating. Screw in the bleed screw, do not overtighten.
2. Lubricate the connection valve (see item 3) with clean hydraulic system mineral oil and then fit the valve into the body ensuring that it slides into position.
3. Fit a new 'O' ring to the spring retaining plug (see item 2). Fit the spring retainer, spring, adjusting washers (if previously fitted), and the spring retaining plug. Position the retaining plug under a press and depress the plug sufficiently to enable the snap ring to be fitted. Remove the valve housing from the press.
4. Inspect the connection valve ball (see item 3) and if not damaged (if damaged renew) place the ball onto its seating. Fit the connection valve retaining plate (see item 3) and secure with the setscrew.
5. Inspect the cut-out valve (see item 4) to ensure that the stop ring is fitted. Lubricate the cut-out valve with clean hydraulic system mineral oil and then fit the valve into position.
6. Fit a new 'O' ring (see item 4) into the cut-out chamber.

Position the valve housing onto a press and then fit the spring seating, spring, adjusting shims (if previously fitted) and spring housing. Apply sufficient pressure onto the spring housing to enable the two retaining screws to be fitted. After tightening the screws remove the valve housing from the press.

7. Lubricate a new sealing ring (see item 5) with clean hydraulic system mineral oil and then fit the ring into position.

8. Fit the sphere to the valve body and torque tighten to the figures quoted in Section G19.
9. Fit the accumulator(s) as described under Hydraulic accumulator - To fit.

Hydraulic accumulator - To test

1. Depressurize the hydraulic system as described in Section G2.
2. Fit the pressure gauge RH 9727 into the service points of the relevant system by means of a suitable high pressure pipe. The service points are located under the left-hand floor area, opposite the brake actuation linkage assembly on right-hand drive cars and on the right-hand inner wing, rearwards of the spring pot on left-hand drive cars as shown in figure G4-1.
3. Start the engine. The gauge needle should immediately rise to approximately (on a new sphere) 62 bar (900 lbf/in²) indicating the nitrogen gas pressure in the accumulator sphere. The pressure

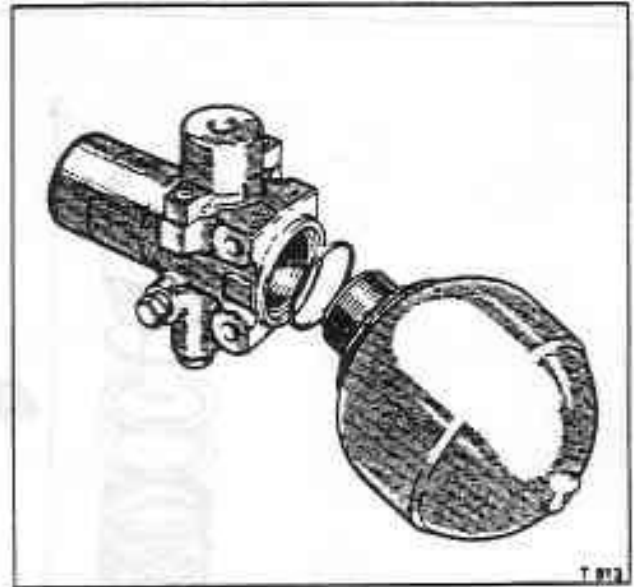

Fig. G7-3 Hydraulic accumulator with sphere removed

- should then slowly rise to a pressure of between 165 bar and 175 bar (2393 lbf/in² and 2538 lbf/in²). At this pressure the accumulator cut-out valve should actuate and the pump cease to charge the accumulator.
4. After the cut-out pressure has been reached note the pressure to which the gauge settles. This settling takes up to one minute and the pressure should not be more than 10 bar (150 lbf/in²) below the cut-off pressure. The pressure should then remain steady unless the brake pedal is applied or the height control system actuated.
5. Fit a bleed tube onto the bleed screw of the gauge connecting pipe. Open the bleed screw and allow the pressure gauge reading to fall. When the pressure has fallen to between 140 bar and 150 bar (2031 lbf/in² and 2176 lbf/in²) the accumulator control valve should allow the hydraulic pump to recharge the accumulator.
6. If, on first starting the engine, the pressure gauge needle fluctuates violently, rapidly climbs to 172 bar (2500 lbf/in²) and then immediately falls to zero on application of the brake pedal, complete loss of nitrogen gas pressure from the accumulator sphere is indicated.
7. In the event of the nitrogen gas pressure of the accumulator being less than 31 bar (450 lbf/in²) refer to Operations 3 and 6, the accumulator sphere must be renewed.
8. If the cut-in and cut-out pressures of the accumulator are outside the limits quoted in Operations 3 and 5 the accumulator valve assembly must be renewed.
9. If the pressure continues to fall the accumulator has reached the cut-out pressure of between 165 bar and 175 bar (2393 lbf/in² and 2538 lbf/in²) and then settles an internal leak is indicated.
10. If observations of the gauge shows that the pump

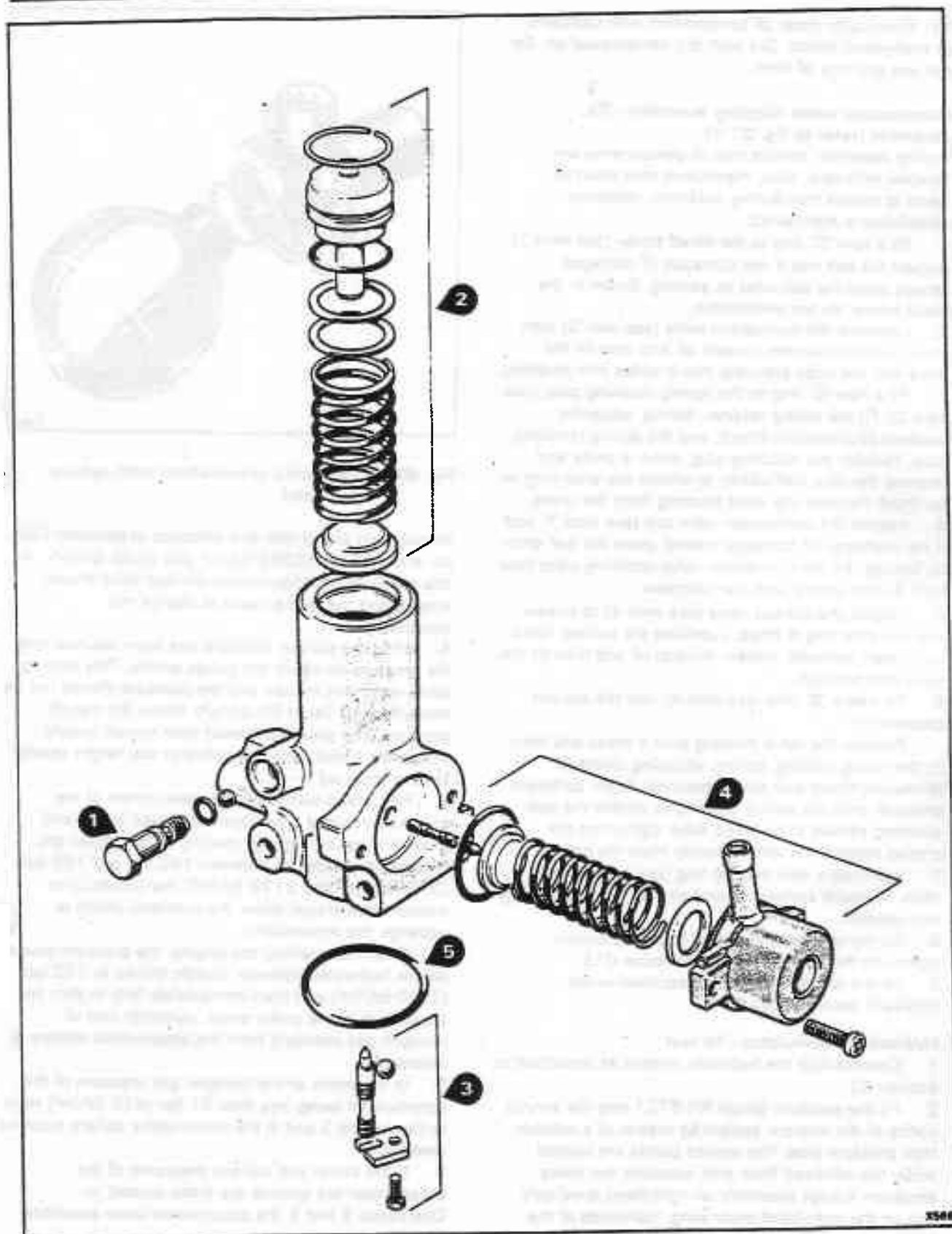

Fig. G7-4 Accumulator valve housing assembly

- 1 Bleed screw, 'O' ring, and seating ball
- 2 Valve housing, retaining plug, and associated components

- 3 Connection valve and associated components
- 4 Cut-out housing and associated components
- 5 'O' ring - Accumulator valve housing to sphere

is still pumping (needle fluctuating with the pump pulses) without giving a rise in pressure then there is a leak equal to the pump flow at that pressure. Pump 'cut-out' indicated by the change of audible note of the pump, can be heard if the end of the engine dipstick is placed on top of the pump and used as a hearing aid."

To verify an accumulator internal leak, depressurize the system and remove the gauge from the service point. Secure the service point to withstand hydraulic pressure.

The following action separates the accumulator from the rest of the system and allows the accumulator and hydraulic pump to be checked thoroughly.

Disconnect the 'accumulator to frame' high pressure steel braided hydraulic hose from the junction block at the engine end. Blank off the steel braided hydraulic hose.

Fit pressure gauge RH 9727 into the junction block. Start the engine and observe the pressure. If symptoms persist (check that the accumulator bleed screw is secure) the accumulator valve assembly has an internal leak and the valve assembly should be renewed. If however the gauge now behaves correctly and the pump can be heard to cut-out, the leakage is occurring downstream and a component isolating procedure should be undertaken.

The component isolating procedure necessary to locate the fault consists of depressurizing the systems then removing or blanking off the pressure feed to the various components in turn and repeating the test procedure.

The pressure feeds to the components can be readily identified from the colour coding chart (see Section G3).

Note

Always ensure that the mineral oil in the reservoirs is above the minimum level at all times during the test procedure.

When a unit has been blanked off, before removing the blank, the systems must be depressurized either by continuous system operation with the engine switched off or by bleeding the appropriate accumulator until it is depressurized.

After tests have been carried out involving blanking off of components, all blanks should be removed and components reconnected. The systems should then be bled in accordance with the information given in Section G4.

Deceleration conscious pressure limiting valve

Introduction

The deceleration conscious pressure limiting valve is non-adjustable and must not be serviced other than for the renewal of valve seals.

If a valve is found to be faulty, usually indicated by premature rear brake locking and renewal of the valve seals does not rectify the problem, it will be necessary to fit a complete deceleration conscious pressure limiting valve.

Under no circumstances should a complete valve assembly or seals for use with conventional brake fluid (i.e. RR363) systems be fitted, as a replacement.

During dismantling cleanliness of components is of the utmost importance.

To enable the valve to be identified as a hydraulic system mineral oil component the body of the valve is coloured green and a green identification tab is fitted to the valve bleed screw.

Deceleration conscious pressure limiting valve -To remove

1. Place the car on a ramp and remove the undershield protecting the brake actuation linkage.
2. Depressurize the hydraulic systems as described in Section G2.
3. Disconnect the two pipes from the pressure limiting valve; blank off the pipe ends and valve ports.
4. Remove the split pins and nuts from the two valve mounting bolts. Withdraw the bolts and remove the valve and distance pieces.

On left-hand drive cars the angular end plate must be removed from the mounting bolts.

Deceleration conscious pressure limiting valve seals - To renew

1. Remove the valve from the car as described under Deceleration conscious pressure limiting valve - To remove.

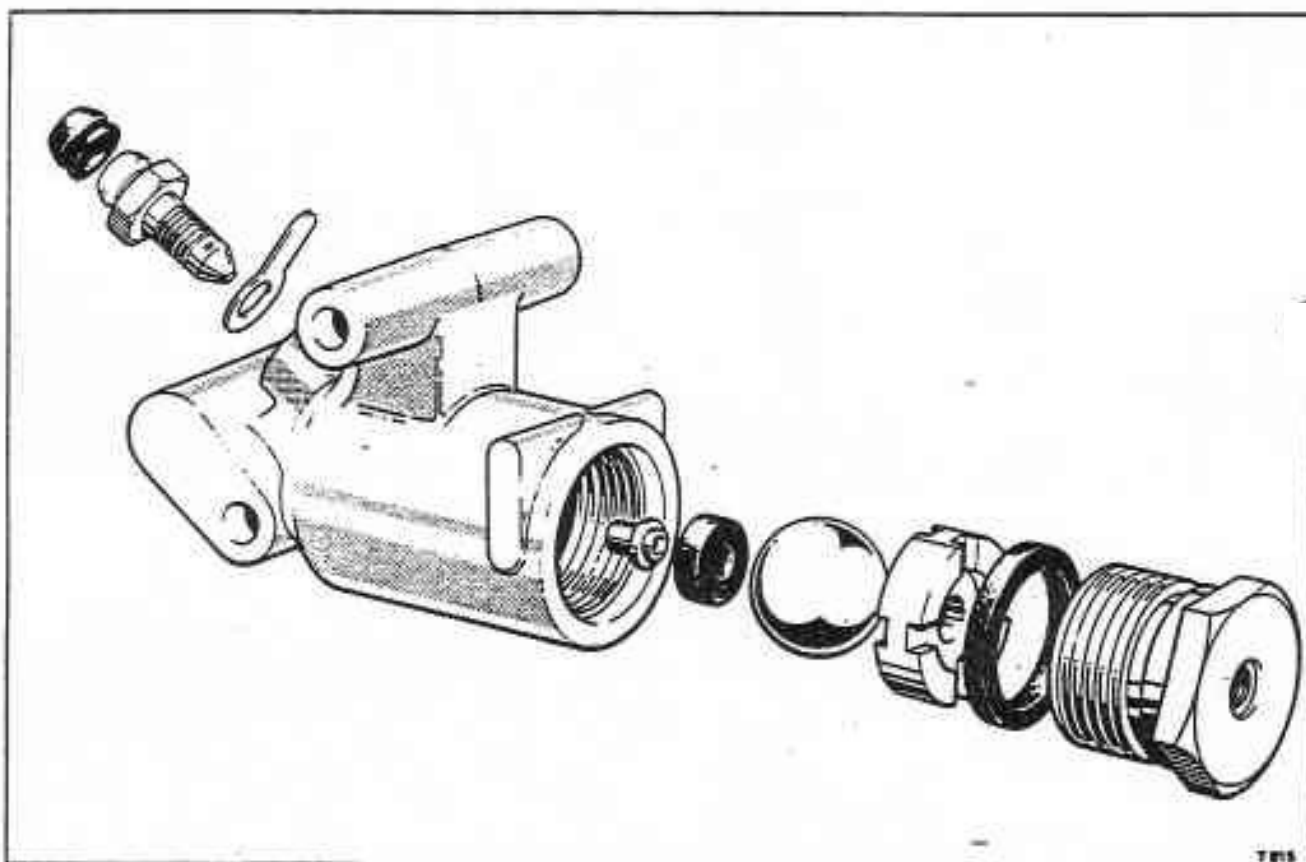

Fig. G8-1 Deceleration conscious pressure limiting valve

2. Unscrew the end plug from the valve. Remove the components and discard the two valve seals.
3. Thoroughly clean all components in either Genkiene or methylated spirits. Dry with dry compressed air, not with any type of cloth.
4. Ensure that the components surfaces are smooth and free from scratches, then assemble the valve using a new valve seal kit.
5. Fit the end plug and torque tighten in accordance with the figures quoted in Section G19.

Deceleration conscious pressure limiting valve -To fit

To fit the pressure limiting valve reverse the procedure given for removal noting the following.

1. All nuts must be torque tightened in accordance with the figures quoted in Section G19 prior to the split pins being fitted.
2. On completion the hydraulic system must be bled as described in Section G4.

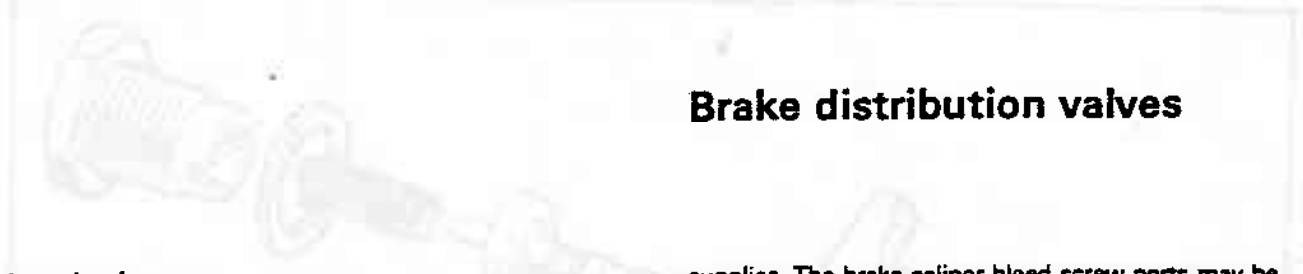

Brake distribution valves

Introduction

The brake distribution valves fitted to cars with mineral oil hydraulic systems are identical in appearance to those fitted to cars using conventional brake fluid (i.e. RR363). In order to identify valves suitable for use with hydraulic system mineral oil the valve body and end plug are painted green.

Under no circumstances should distribution valves for use with a conventional brake fluid system be fitted as a replacement.

The distribution valves are situated one above the other within the brake actuation linkage assembly. They are operated through linkage and a balance lever arrangement when the footbrake is applied (see fig. G10-1).

Both valves are identical in operation but have differing mounting points and pipe arrangements. Corresponding valves on right-hand and left-hand drive cars are identical.

Complete distribution valve assemblies are available as service exchange units. Only the rubber end cover, return spring, and end plug sealing washer are available as separate items. The remaining working parts are subject to very fine limits and are therefore selectively assembled by the manufacturer.

Note

The design of the valve is such that to provide adequate lubrication to the 0.0025 mm (0.0001 in) clearance between the operating valve and its bore, a small hydraulic system mineral oil 'leak-off' is permitted. This leakage is visible and takes the form of a small droplet of mineral oil hanging from the valve base. This is normal.

To determine if a valve is leaking excessively requiring renewal or overhaul, check that the 'leak-off' does not impair the braking efficiency of the car or cause a noticeable drop of hydraulic system mineral oil in the reservoir. If these conditions are satisfactory the valve should be regarded as serviceable.

Brake distribution valve - To test (on the car)

1. Place the car on a ramp. Isolate the gearchange selector and depressurize the systems as described in Section G2.
2. Remove the undershield from around the brake actuation linkage.
3. Connect a zero to 207 bar (zero to 3000 lbf/in²) pressure gauge RH 9727 with a length of high pressure pipe, attached into the high pressure outlet port of the distribution valve (blue or mauve pipe). Alternatively, connect the gauge into any convenient junction between the valve and the brake calipers it

supplies. The brake caliper bleed screw ports may be used if desired.

4. Start the engine then depress the brake pedal. The brake line pressure shown on the gauge should be proportional to the load applied to the pedal, provided the accumulators are fully charged. For a 200 N (45 lbf) load on the pedal, the line pressure should be approximately 69 bar (1000 lbf/in²). It should also be possible to achieve a line pressure of 138 bar (2000 lbf/in²) for a pedal pressure of approximately 333 N (75 lbf).

When the brake pedal load is varied continuously the brake line pressure should vary accordingly, without any marked lag or jerkiness.

If the above effort/pressures are not obtainable or actuation shows marked lag or jerkiness on the gauge, the distribution valve may be considered faulty and must be overhauled or renewed.

5. If a system internal leakage investigation, as described under Hydraulic accumulators - To test, show a distribution valve to be the cause of a loss in accumulator pressure the actual leakage can be checked as follows.

6. Disconnect the low pressure return line from the distribution valve port (black or white pipe). Blank the end of the pipe to prevent drainage of the reservoir.

7. Insert a union and a length of pipe into the distribution valve low pressure return port and place the open end of the pipe into a clean container.

8. Start the engine but do not depress the footbrake pedal.

9. Top-up the reservoir continuously to prevent the hydraulic system mineral oil from falling below the 'add' level mark.

For the valve to be acceptable the hydraulic system mineral oil leakage should not exceed 25 ml (0.875 fl oz) per half hour with the valve in the 'off' position (i.e. brake pedal not applied) or 50 ml (1.750 fl oz) per minute with the brake pedal depressed and held steady under a load of 200 N (45 lbf). This load is equivalent to a brake line pressure of 69 bar (1000 lbf/in²). If the valve leakage exceeds these figures it must be overhauled or renewed.

Brake distribution valves - To remove

1. Place the car on a ramp and depressurize the hydraulic systems as described in Section G2.
2. Remove the undershield from around the brake actuation linkage.
3. Remove the pipes from each valve. Blank off the pipe ends and valve ports.
4. Unlock and remove the securing bolts from each valve, draw the rubber boot seal off the valve. Taking

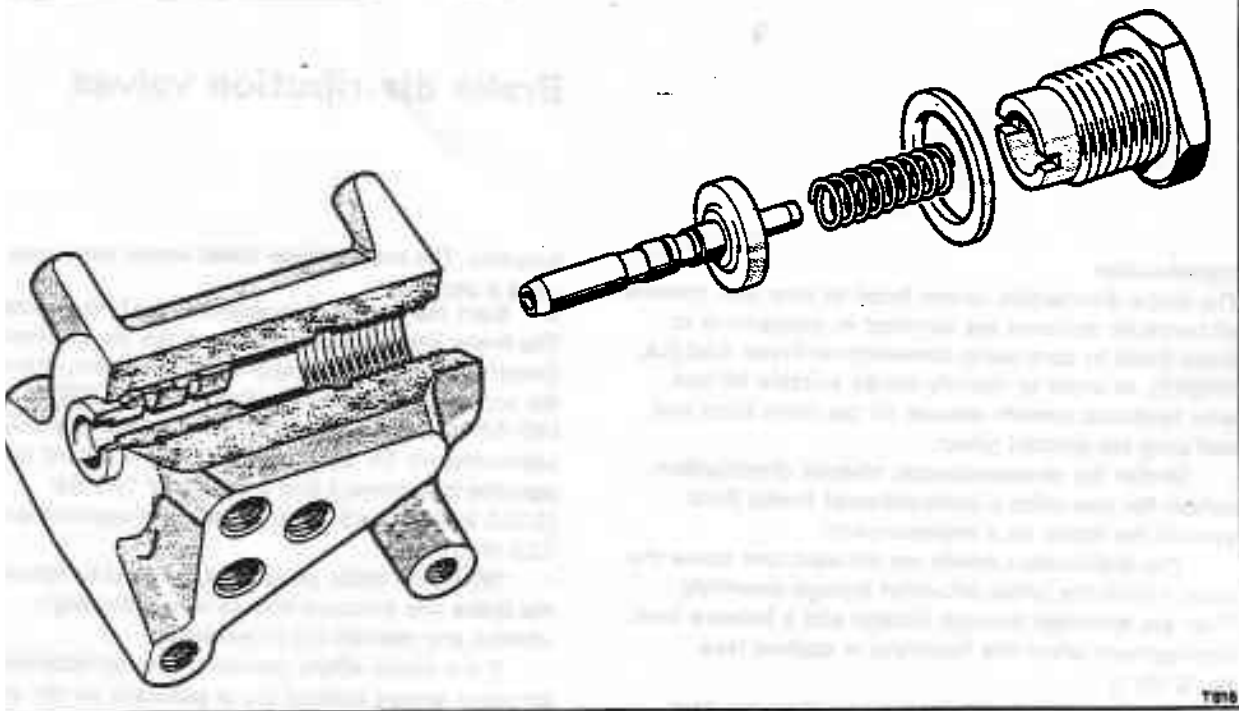

G9-1 Brake distribution valve

Do not to bend the valve actuation push rod, move the valve forward and downward, out of the actuation linkage assembly.

Brake distribution valve - To dismantle (see fig. G9-1)

Remove the end plug and sealing washer; collect return spring.

Carefully remove the valve stem. Extreme care should be taken to ensure that the valve stem and its seating bore do not become scratched or damaged.

Carefully wash all parts in either Genkrene or methylated spirits and dry with clean, dry compressed air. Do not use any form of cloth.

Brake distribution valve - To inspect

Carefully examine the fine limit bore of the valve insert and the outside diameter of the valve stem. Each face should be smooth and free from scratches.

Lubricate the bore of the valve insert and the valve stem with clean hydraulic system mineral oil. Fully fit the valve stem into the valve insert bore and check for any axial wear. There should only be sufficient clearance to allow the valve stem to slide freely in the bore; the stem and bore having a clearance of 0,0025 mm (0.0001 in).

Wash the parts in either Genkrene or methylated spirits and dry with clean dry compressed air. Do not use any form of cloth.

Brake distribution valve - To assemble

Lubricate the bore of the valve insert and the

valve stem with an approved hydraulic system mineral oil (see Chapter D).

2. Carefully insert the valve stem into the valve insert bore until fully seated. Fit a new return spring.

3. Fit a new sealing washer to the end plug. Fit and torque tighten the plug to the figures quoted in Section G19.

4. Ensure that the inward and return movement of the valve stem is smooth and does not bind or stick at any point along its travel.

Brake distribution valves - To fit-

Fit the distribution valves by reversing the procedure given for removal noting the following.

1. If a replacement valve is being fitted, remove one of the blanking plugs and allow any hydraulic system mineral oil to drain from the valve. Fit the plug.

2. Torque tighten the mounting bolts and pipe connections in accordance with the figures quoted in Section G19 and Chapter P. Lock the securing bolt tab-washers.

3. On completion the hydraulic system must be bled as described in Section G4.

Brake actuation linkage assembly

Contents	Pages					
	Silver Spirit Mulsanne	Silver Spur	Mulsanne Turbo	Bentley Eight	Bentley Turbo R	Corniche/ Continental
Introduction	G10-3	G10-3	G10-3	G10-3	G10-3	G10-3
Brake actuation linkage assembly - To remove	G10-4	G10-4	G10-4	G10-4	G10-4	G10-4
Brake actuation linkage - To dismantle	G10-5	G10-5	G10-5	G10-5	G10-5	G10-5
Brake linkage assembly bushes and pivot pins - To renew	G10-5	G10-5	G10-5	G10-5	G10-5	G10-5
Brake actuation linkage - To assemble	G10-5	G10-5	G10-5	G10-5	G10-5	G10-5
Brake actuation linkage - To adjust	G10-6	G10-6	G10-6	G10-6	G10-6	G10-6
Distribution valve push rods - To set	G10-6	G10-6	G10-6	G10-6	G10-6	G10-6
Rubber 'feel' cone - To set	G10-6	G10-6	G10-6	G10-6	G10-6	G10-6
Main 'feel' spring - To set	G10-7	G10-7	G10-7	G10-7	G10-7	G10-7
Brake pedal height setting	G10-7	G10-7	G10-7	G10-7	G10-7	G10-7
Brake pedal height - To check	G10-7	G10-7	G10-7	G10-7	G10-7	G10-7
Brake pedal lever - To remove	G10-8	G10-8	G10-8	G10-8	G10-8	G10-8
Brake pedal lever - To fit	G10-8	G10-8	G10-8	G10-8	G10-8	G10-8
Brake stop lamp and speed control switches - To adjust	G10-8	G10-8	G10-8	G10-8	G10-8	G10-8

Brake actuation linkage assembly

Introduction

The brake actuation linkage assembly is mounted just rearward of the toeboard. On right-hand drive cars the assembly is positioned just inboard of the body sill. On left-hand drive cars the assembly is fitted adjacent to the inner side of the body longeron.

The assembly houses the distribution valves, deceleration conscious pressure limiting valve, speed control switch, and the stop lamp switch. The assembly being the same for both right and left-hand drive cars.

Always ensure that replacement distribution valves and the deceleration conscious pressure limiting

valve fitted to this assembly are for use with hydraulic system mineral oil and bear the relevant identification markings (see Sections G8 and G9).

Under no circumstances must valves for use with conventional brake fluid systems (i.e. RR363) be used for replacements.

On cars from and including the following vehicle identification numbers (VIN) a new stop lamp and speed control switch assembly unit is fitted (see fig. G10-4).

Silver Spirit *SCAZS42A8FCX13483*

Silver Spur *SCAZN42A7FCX13451*

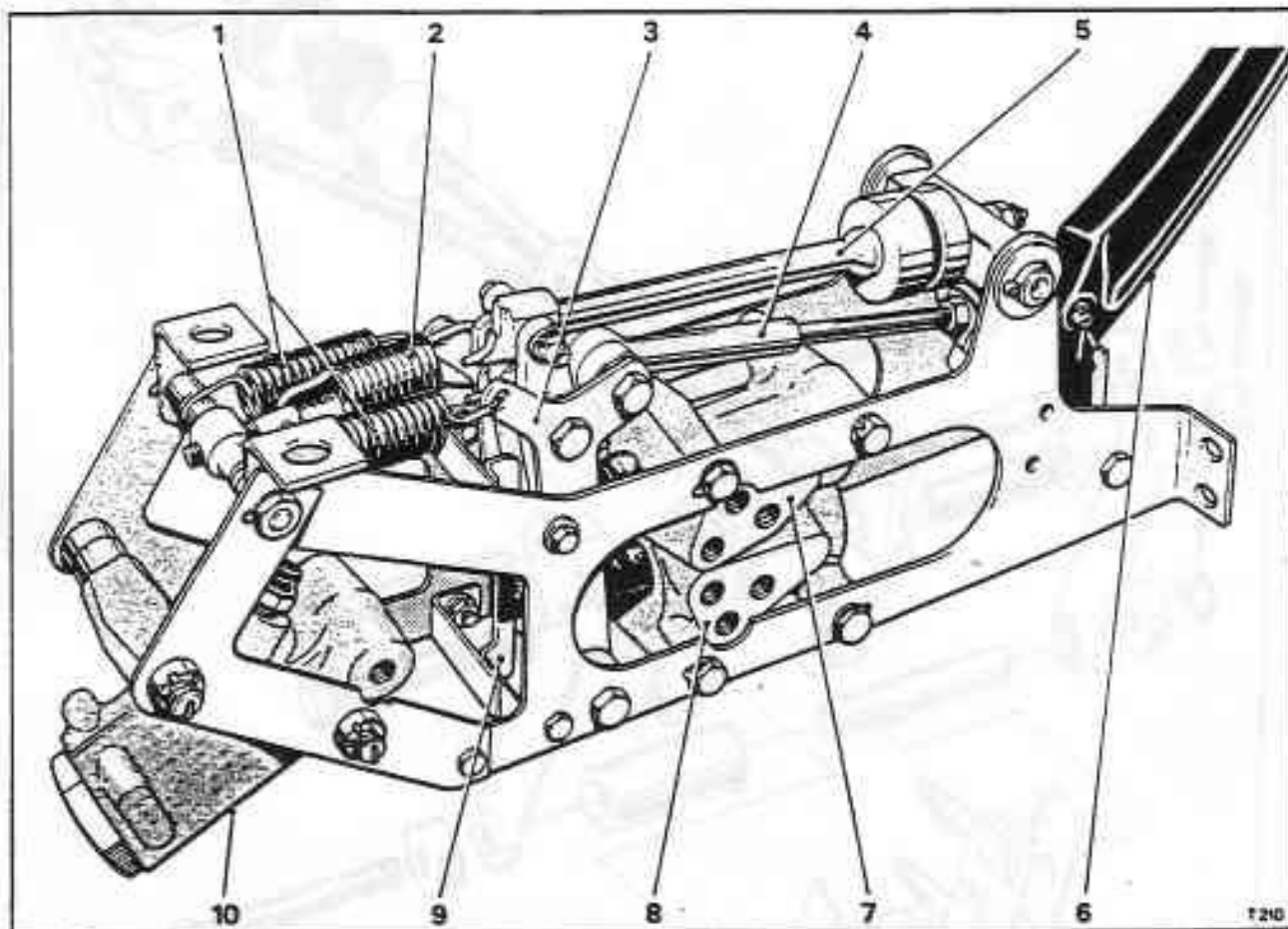

Fig. G10-1 Brake actuation linkage assembly

- | | |
|---------------------------------|---|
| 1 Return springs | 6 Brake pedal lever |
| 2 Pedal 'feef' spring | 7 Upper distribution valve (No. 1 system) |
| 3 Balance lever assembly | 8 Lower distribution valve (No. 2 system) |
| 4 Brake actuation operating rod | 9 Off stop bracket |
| 5 Pedal 'feef' rod | 10 Deceleration conscious pressure limiting valve |

Bentley Mulsanne and Mulsanne Turbo
 from *SCBZS0T04FCH13452* including
 SCBZN0T03FCH13394
 Bentley Turbo R *SCBZS0T00FCH13460*
 Comiche/Continental
 from *SCAZD42AXGCX13528* including
 SCAZD42A5GCX13470
 SCAZD42A9GCX13472
 SCAZD42A2GCX13524
 SCAZD42A6GCX13526

Brake actuation linkage assembly - To remove

1. Place the car on a ramp; depressurize the hydraulic

systems as described in Sections G2 and G2/1.

2. Turn the battery master switch to the off position.

3. Remove the undershield from around the linkage assembly.

4. Disconnect the Lucar connections, then remove the brake stop lamp switch, speed control switch, and mounting bracket.

5. Remove the brake pedal pinch bolt from the upper end of the brake pedal lever and ease the pedal stem out of the lever. Collect the rubber seal.

6. Disconnect the pipes from the distribution valves and deceleration conscious pressure limiting valve. Blank off all exposed pipe ends and valve ports.

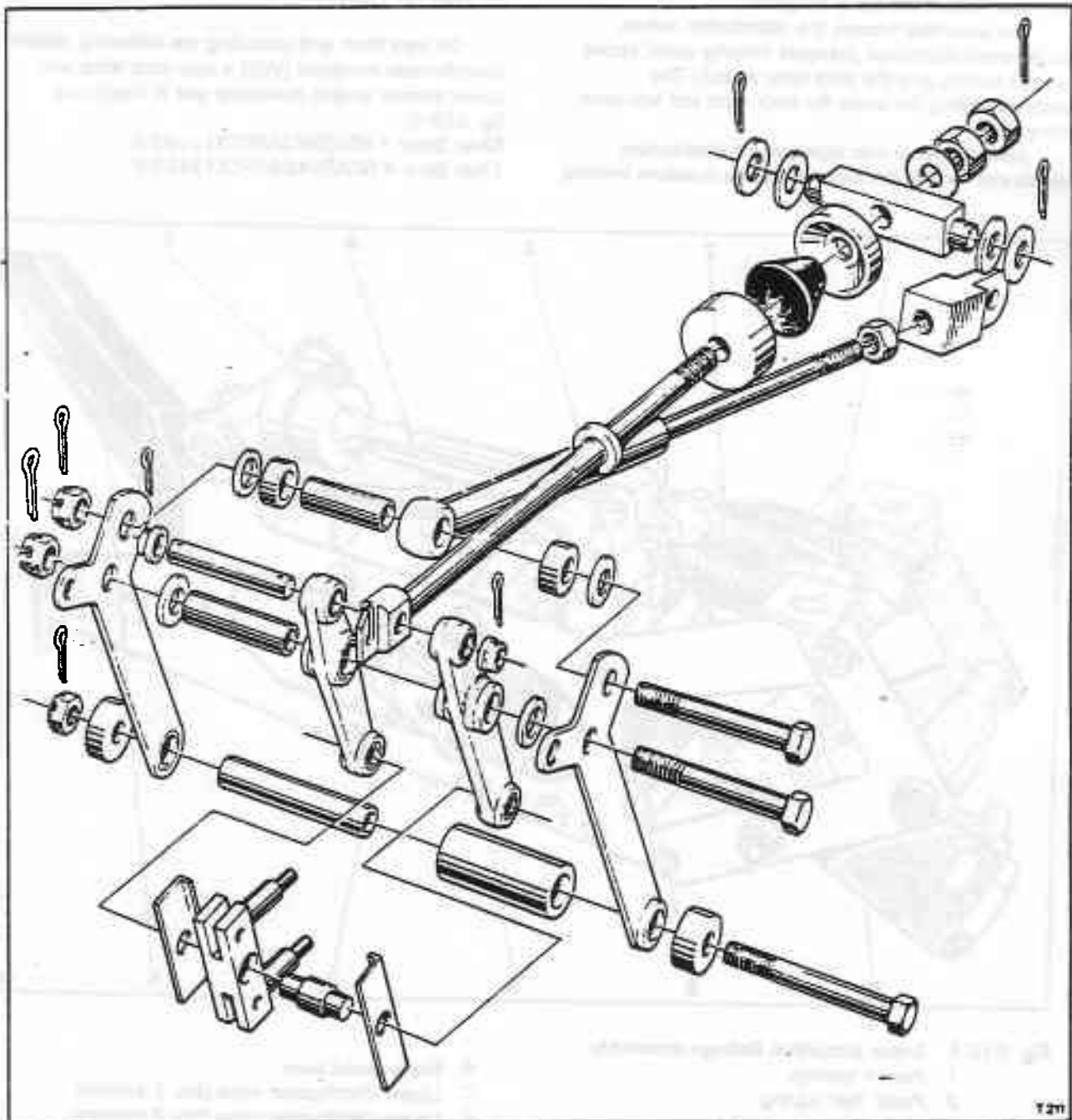

Fig. G10-2 Brake actuation linkage balance lever assembly

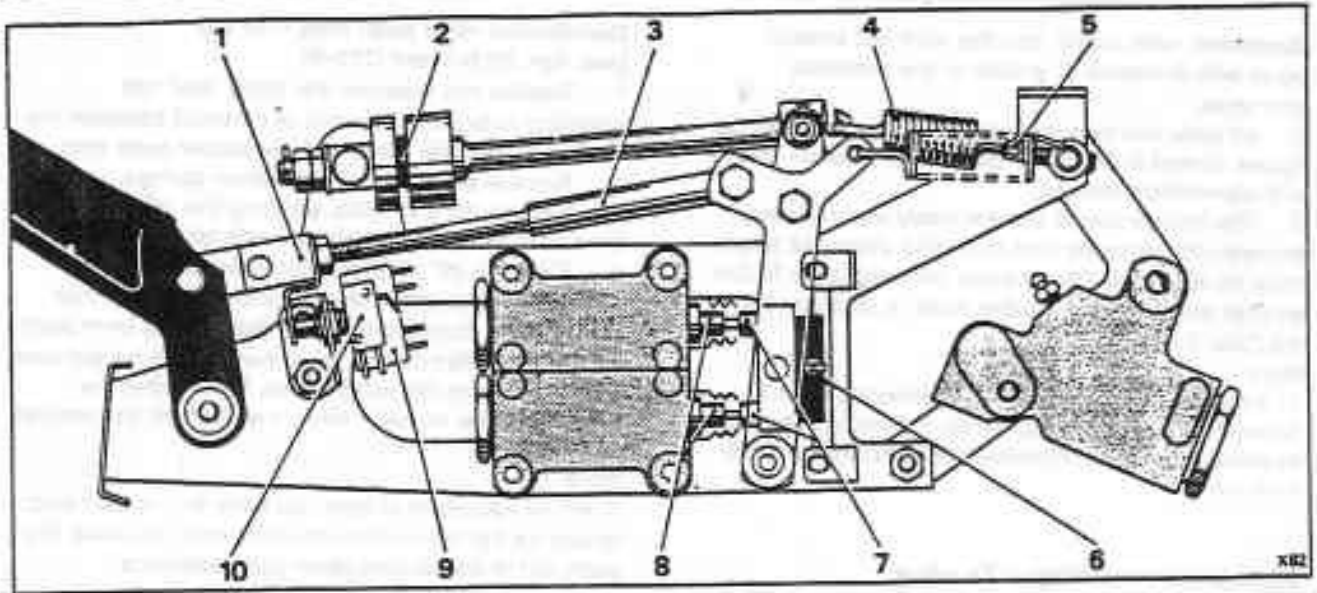

Fig. G10-3 Brake actuation linkage adjustment points (early type)

- | | |
|--------------------------------------|----------------------------|
| 1 Brake pedal lever adjustment block | 6 Off stop bracket |
| 2 Rubber 'feel' cone | 7 Balance lever push rods |
| 3 Brake actuation operating rod | 8 Distribution valve stems |
| 4 Main 'feel' spring | 9 Brake stop lamp switch |
| 5 Feel spring adjustment screw | 10 Speed control switch |

7. On right-hand drive cars disconnect the petrol pipe clip from the linkage side mounting bracket.
8. Remove the setscrews (right-hand drive cars) or bolts and nuts (left-hand drive cars) securing the linkage assembly side plates at the forward end. Support the linkage assembly and remove the two rear securing setscrews. Lower the assembly from the car.

On left-hand drive cars, the brake pedal lever must be withdrawn from the rubber sealing boot when lowering the actuation linkage from the car.

Important

Under no circumstances should the brake actuation assembly be allowed to hang from the brake pedal, supported by the actuation rod, as this may result in the rod being bent.

Brake actuation linkage - To dismantle

Prior to dismantling the linkage a note should be taken of the relative positions of the distance pieces and bolt direction (see figs. G10-1 and G10-2).

1. Remove the brake actuation linkage from the car as described previously.
2. Remove the split pin and clevis pin from the operating rod pivot on the brake pedal lever.
3. Remove the three springs from the rear of the linkage.
4. Remove the split pin and nuts from the end of the pedal 'feel' rod.
5. Remove the 'off' stop bracket from behind the balance levers.
6. Remove the pivot bolt from the lower end of the balance levers. Ease the levers rearward and carefully withdraw the balance lever push rods from the

- distribution valves. Remove the distance pieces and pivot tube from the lower end of the balance levers.
7. Lift the levers clear of the side plates and withdraw the 'feel' rod from its retaining bar. Collect the conical rubber and abutment cups.
8. Remove the split pin from one side of the 'feel' rod pivot pin, withdraw the pin and collect the collar.
9. Remove the two bolts retaining the pivot arms to the balance levers. Noting their positions collect the washers, distance pieces, and pivot tubes.
10. Remove the balance levers from each side of the distribution valve push rod equalizing block, collect the pin retaining plates.

Note

The levers and pivot pins are clearance fits and are easily removed.

Brake linkage assembly bushes and pivot pins - To renew

1. Remove and dismantle the brake linkage as described previously.
2. Carefully press the bushes requiring renewal out of their locations and fit new bushes. The bush bores are machined to final size, therefore no reaming or boring is necessary.
3. Any pivot pins that are worn or damaged must be renewed.

Brake actuation linkage - To assemble

Assemble the linkage by reversing the dismantling procedure noting the following.

1. Clean all components prior to assembly. Lightly lubricate the linkage pivots, the protruding parts of the

distribution valve stems, and the push rod location bores with Molytone 'C' grease or any approved alternative.

2. All bolts and nuts must be torque tightened to the figures quoted in Chapter P before split pins are fitted and tab-washers secured.
3. The linkage should operate freely when located between the assembly side mounting plates. All levers must be absolutely free to move with negligible friction on their pivots. Distance tubes must be similarly free in the Oilite bushes.

Note

All bolts should be fitted in the directions shown in figure G10-1 in order that certain individual items may be removed without removing the complete assembly from the car.

Brake actuation linkage - To adjust

Adjustment of the actuation linkage should be carried out in the following sequence.

- a. Distribution valve push rod clearance.
- b. Rubber 'feel' cone setting.
- c. Main 'feel' spring setting.
- d. Brake pedal height setting.

Note

Adjustment 'a', 'b', and 'c' can be carried out with the actuation linkage assembly removed from the car.

Distribution valve push rods - To set (see figs. G10-3 and G10-4)

1. Slacken and unscrew the brake 'feel' rod adjusting nuts until clearance is obtained between the 'feel' rod mounting block and the rubber cone seat.
2. Remove the 'feel' rod and return springs.
3. Slacken the four bolts securing the 'off' stop bracket to the actuation linkage side plate.
4. Slide the 'off' stop bracket forward on the elongated holes until a clearance of up to 0,25 mm (0.010 in) is obtained between the balance lever push rods and the distribution valve stems; with no pre-load being applied to the valve stems. Ensure that the setting is equal on each valve, then tighten the bracket securing bolts.

Note

It will be necessary to draw back the two rubber dust covers on the distribution valves in order to check the push rod to distribution valve stem clearance.

Rubber 'feel' cone - To set (see figs. G10-3 and G10-4)

1. Fit the two return springs to the linkage assembly. At this point the two abutment cups and the rubber 'feel' cone should be loose and free to slide on the shaft.
2. Tighten the adjusting nut until the clearance between the abutment cups and the rubber cone has

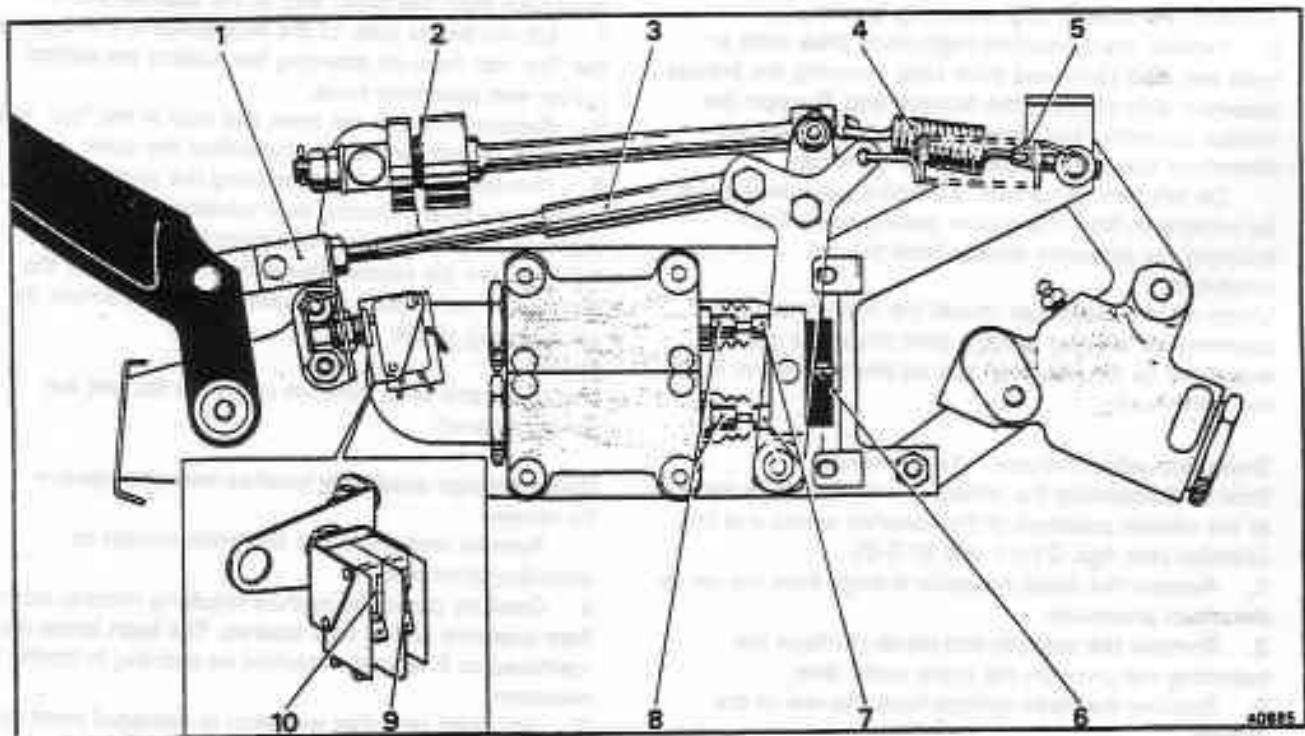

Fig. G10-4 Brake actuation linkage adjustment points (later type)

- | | |
|--------------------------------------|----------------------------|
| 1 Brake pedal lever adjustment block | 6 Off stop bracket |
| 2 Rubber 'feel' cone | 7 Balance lever push rods |
| 3 Brake actuation operating rod | 8 Distribution valve stems |
| 4 Main 'feel' spring | 9 Brake stop lamp switch |
| 5 Feel spring adjustment screw | 10 Speed control switch |

been removed, without a pre-load being applied to the rubber cone.

3. Securely tighten the lock-nut onto the adjusting nut, then depress and release the brake pedal several times to ensure that the cone is seated correctly. Re-check the cone setting. Ensure that a security split pin is fitted to the end of the shaft.

Main 'feel' spring – To set (see figs. G10-3 and G10-4)

1. Ensure that the actuation assembly remains in the 'off' position.

2. Fit one end of the 'feel' spring into the adjusting screw located in the centre of the spring anchor rod.

3. Rotate the spring and screw half a turn at a time in the direction required until the spring can be fitted into the 'feel' rod hook. With no clearance between the spring and hook, ensure that there is no spring pre-load.

Note

It is necessary to stretch the spring over the hook to obtain the correct position where clearance is determined.

4. Remove the spring from the hook and rotate the spring and screw 1½ turns clockwise, when viewed from the brake pedal end of the assembly (i.e. effectively tensioning the spring). Fit the spring onto the hook.

Note

It is essential to follow both of the previous setting instructions accurately as deviations will completely alter the subjective feel and acceptability of brake control.

Clearance between the rubber 'feel' cone and its abutments will cause a spongy, long travel pedal feel at low decelerations. Any pre-load on this rubber will cause jerky initial braking under these conditions. Inadequate pre-load on the rear tension spring will produce unwanted free travel at the pedal followed by jerky initial braking. Too much pre-load will give jerky initial braking followed by a period of 'spongy' pedal travel.

Brake pedal height setting (see figs. G10-5 and G10-6)

This setting can only be carried out with the actuation linkage assembly fitted to the car.

1. Locate the setting gauge into the brake pedal stem hole in the end of the pedal lever (see fig. G10-5). Raise the pedal lever until the gauge touches the underside of the toeboard seal housing.

2. Adjust the block on the lever operating rod until the hole in the block aligns with the hole in the pedal lever.

Note

Shortening the rod length reduces the gap between the pedal lever and seal plate, half a revolution of the block being equal to approximately 3,17 mm (0.125 in) of pedal lever movement.

3. Remove the setting gauge from the brake lever. Connect the rod to the lever by inserting the clevis pin. Fit the split pin.

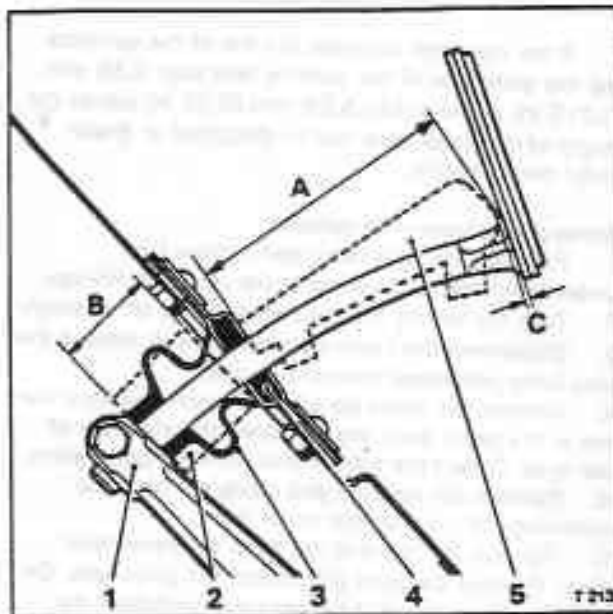

Fig. G10-5 Brake pedal height settings

- 1 Brake lever
- 2 Brake lever setting gauge
- 3 Rubber seal
- 4 Toeboard seal and housing
- 5 Pedal height checking template
- A 99,06 mm to 98,30 mm (3.90 in to 3.870 in)
- B 38,10 mm to 37,97 mm (1.50 in to 1.495 in)
- C 0,38 mm to 5,08 mm (0.015 in to 0.20 in)

4. Fit the rubber seal between the brake pedal lever and toeboard seal plate.

On left-hand drive cars slide the convoluted rubber seal over and down the brake pedal lever; fit the two retaining screws and washers. Ensure that the seal does not prevent the lever and linkage returning to the fully 'off' position.

5. Insert the brake pedal through the toeboard felt and rubber seals into the hole in the brake pedal lever.

6. Fit and tighten the pinch bolt to secure the brake pedal lever.

7. Check that the rubber seal does not prevent the actuation linkage returning to the 'off' position and that the brake pedal does not foul the seal housing at any point along its travel.

8. Fit the brake stop lamp and speed control switches. Adjust the setting as described under, Brake stop lamp and speed control switch - To adjust.

Brake pedal height – To check (see fig. G10-5)

1. Place the checking template between the underside of the brake pedal and the upper surface of the pedal seal housing with the two lugs of the gauge located under the pedal stem. Rest the flat base of the template on the seal housing. Ensure that both carpet and underlay are removed from the housing surface.

2. If the clearance between the top of the template and the underside of the pedal is less than 0,38 mm (0.015 in) or more than 5,08 mm (0.20 in) adjust the length of the pedal lever rod as described in Brake pedal height setting.

Brake pedal lever – To remove

1. Place the car on a ramp and remove the undershield from around the brake actuation linkage.
2. Turn the battery master switch to the off position.
3. Disconnect the Lucar connections and remove the stop lamp and speed control switches.
4. Remove the brake pedal stem pinch bolt from the top of the pedal lever and withdraw the stem out of the lever. Collect the rubber seal from the pedal stem.
5. Remove the split pin and clevis pin from the operating rod pivot on the pedal lever.
6. Remove the bolt and nut from the pedal lever pivot. Remove the lever and collect the pivot tube. On left-hand drive cars it is necessary to withdraw the lever from the convoluted rubber seal during final removal.

Brake pedal lever – To fit

To fit the brake pedal lever reverse the procedure given for removal noting the following.

1. All nuts must be torque tightened to the figures quoted in Chapter P.
2. The pedal lever, stop lamp, and speed control switches must be checked for correct operation and adjusted if necessary, as described under the appropriate headings in this Section.

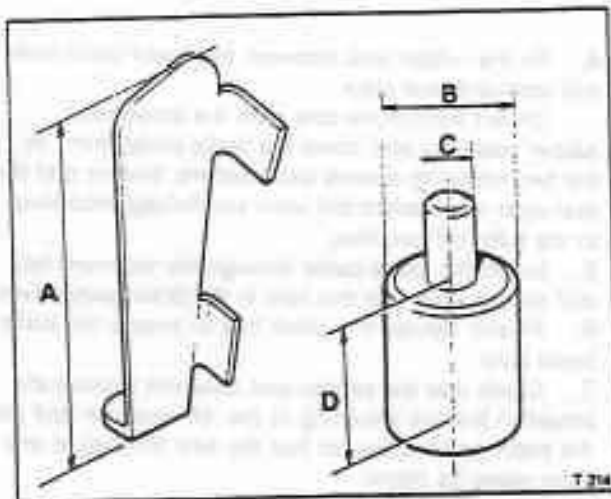

Fig. G10-6 Brake pedal setting and checking template

- A 99,06 mm to 98,30 mm
(3.90 in to 3.870 in)
- B 34,92 mm to 34,29 mm
(1.375 in to 1.350 in)
- C 12,50 mm to 12,44 mm
(0.492 in to 0.490 in)
- D 38,10 mm to 37,97 mm
(1.50 in to 1.495 in)

Brake stop lamp and speed control switches – To adjust

Cars prior to the vehicle identification numbers quoted in the Introduction on page G10-3 (see fig. G10-3)

With all other adjustments to the brake actuation linkage and brake pedal completed, set the brake stop lamp and speed control switches as follows.

1. Slacken the nuts retaining the switches to the switch mounting bracket.
2. Adjust the nuts until the switches just make contact with the striker plate.
3. Adjust the brake stop lamp switch towards the striker plate by a further 1 mm (0.040 in), (i.e. eight flats of the nut). Tighten the lock-nut.
4. Adjust the speed control switch towards the striker plate by a further 1,25 mm (0.050 in), (i.e. ten flats of the nut). Tighten the lock-nut.
5. Check the efficiency of the stop lamp and speed control switches, using an ohmmeter. The stop lamps should operate and the speed control release, with less than 13 mm (0.50 in) of brake pedal travel.
6. Check that the whole mechanism operates smoothly.

Cars from vehicle identification numbers quoted in the Introduction on page G10-3 (see fig. G10-4)

With all other adjustment to the brake actuation linkage and brake pedal completed, set the brake stop lamp and speed control switch as follows.

1. Ensure that the foot brake pedal is in the off position.
 2. Slacken the nuts retaining the switch assembly. Allow the assembly sufficient movement to enable the push button to be depressed fully against the striker plate of the foot brake lever.
 3. Position the switch assembly so that the push button is depressed against the foot brake striker plate, fully depressing the two switch contacts.
- Note**
Care must be taken not to deflect the mounting bracket.
4. Tighten each lock-nut.
 5. Check the efficiency of the stop lamp and speed control switches, using an ohmmeter. The stop lamps should operate and the speed control release, with less than 13 mm (0.50 in) of brake pedal travel.
 6. Reset the switch assembly if the required setting is outside the specified tolerance.
 7. Tighten each lock-nut.
 8. Check that the whole mechanism operates smoothly.

Priority valves/pressure switch

Introduction

The priority valves/pressure switches are mounted on the underside of the body on the rear seat heelboard.

A priority valve/pressure switch is incorporated into the supply line to each height control valve. The right-hand switch is incorporated into the number 1 system, the left-hand switch into the number 2 system.

The function of the priority valves is to prevent the flow of hydraulic system mineral oil to the height control valve until a pressure of between 87 bar and 120 bar (1250 lbf/in² and 1750 lbf/in²) is attained in the accumulators. This flow prevention ensures there is sufficient pressure in the hydraulic systems to operate the height control mechanism without jeopardising the braking efficiency of the car.

If the pressure in the hydraulic braking system(s) falls unduly while the engine is running, the priority valve(s) will close and isolate the suspension height control mechanism. The reduced hydraulic pressure is then totally utilized for braking purposes.

The pressure switches are actuated by the hydraulic system mineral oil in the hydraulic systems and will illuminate the warning panel(s) situated on the fascia if the pressure in the hydraulic system(s) falls below a safe working pressure. It is therefore important that the switches are operated correctly at all times.

In the event of a pressure switch failure the complete priority valve/pressure switch must be renewed.

A priority valve/pressure switch may be overhauled involving the replacement of the 'O' ring and an aluminium washer located on the small end plug.

On Corniche motor cars upto and including vehicle identification number (VIN)

SCAYD000BCHO4488 the priority valves/pressure switch cannot be overhauled, they must be discarded and a new replacement fitted.

The dual purpose priority valve/pressure switch is for use with hydraulic system mineral oil only and can be identified by the green outer body. **Important**

If contamination of the hydraulic system has occurred, overhauling of the unit is essential, and a thorough cleansing of components in Genklene or methylated spirits is of the utmost importance. Also, dry with dry compressed air, not any type of cloth.

Priority valve/pressure switch - To remove (see fig. G11-1)

1. Depressurize the hydraulic systems as described

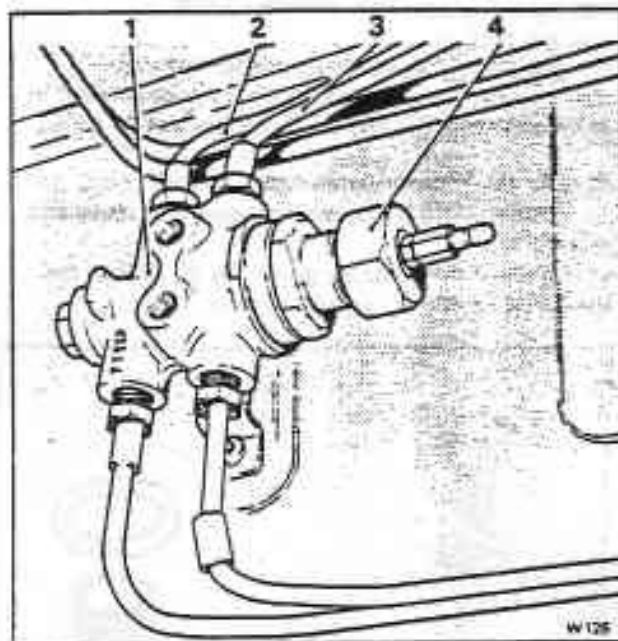

Fig. G11-1 Priority valve/pressure switch

- 1 Priority valve body
- 2 High pressure line (Red No. 1 system, Orange No. 2 system)
- 3 Low pressure line (Black No. 1 system, White No. 2 system)
- 4 Pressure switch

in Section G2.

2. Disconnect the electrical connection from the pressure switch.
3. Disconnect the inlet (2) and outlet (2) pipe connections from the priority valve.
4. Unscrew the bracket retaining screws (self-tapping). Remove the valve and bracket assembly.
5. Remove the priority valve/pressure switch from the bracket.

Priority valve/pressure switch - To dismantle (see fig. G11-2)

1. Unscrew and remove the switch housing cap. Remove the terminal post taking care not to lose the shim from the terminal post. Discard the 'O' ring.
2. Unscrew and remove the adapter union, and collect the components.
3. Unscrew the small end plug and remove the plunger valve.
4. Thoroughly clean all components in Genklene or methylated spirits. Dry with dry compressed air, not with any type of cloth.

Priority valve/pressure switch - To assemble (see fig. G11-2)

1. Reverse the procedure given for dismantling, ensuring that a new 'O' ring and an aluminium washer are fitted.
2. Torque tighten in accordance with the figures quoted in Section G19.

Priority valve/pressure switch - To fit (see fig. G11-1)

1. Reverse the procedure given for removal, ensuring that the connections are torque tightened in accordance with the figures quoted in Section G19.

Priority valve/pressure switch - To test

1. Depressurize the hydraulic systems as described in Section G2.
2. Connect the pressure gauge RH 9727 into the service points of the relevant system.

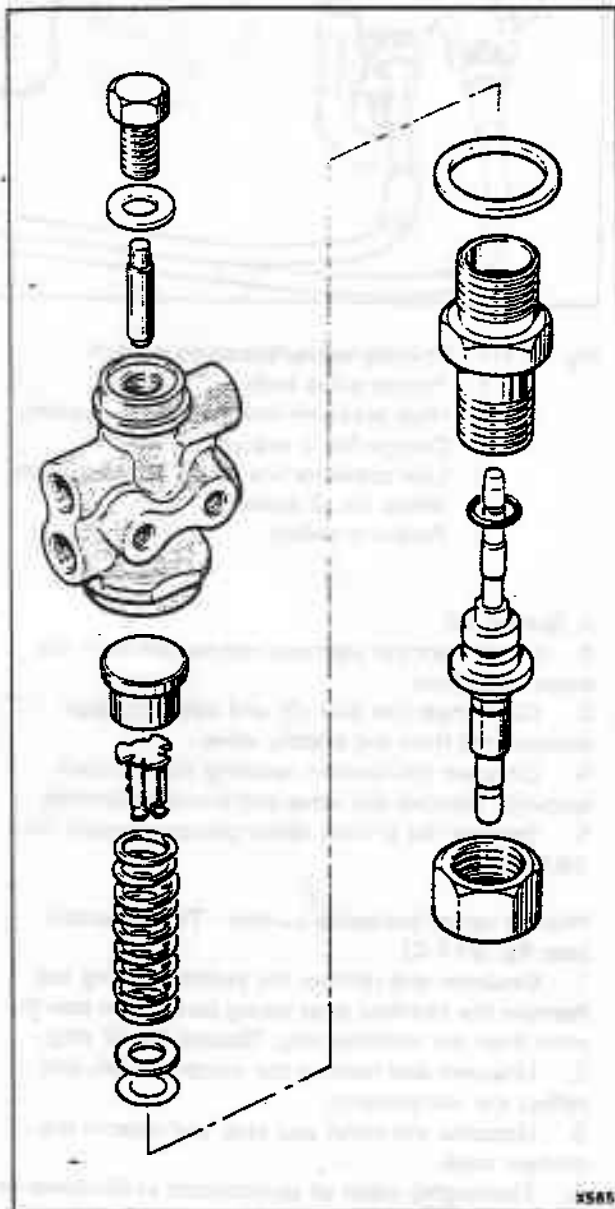

Fig. G11-2 Priority valve/pressure switch

On right-hand drive cars the service points are located under the left-hand floor area opposite the brake distribution valve assembly. On left-hand drive cars the service points are located on the right-hand inner wing, rearward of the spring pot as shown in figure G4-1.

3. Add weight to the luggage compartment of the car equal to 140 kg (300 lb).
4. Start and run the engine at approximately 1000 rev/min.
5. Note the pressure registered on the pressure gauge at the point that the car commences to level. This pressure must not exceed 120 bar (1750 lbf/in²).

The pressure switch lamp will extinguish before the valve opens and when the maximum pressure has been attained.

6. Switch off the ignition.
7. Attach bleed pipes to the rear suspension strut bleed screws.

Carefully open the bleed screws, and allow the hydraulic system mineral oil to flow into a clean container until the levelling system is fully exhausted, indicating that the priority valve has closed.

Whilst the pressure is decreasing the priority valve must close before the warning lamp operates.

8. The pressure retained in the braking system and registered on the pressure gauge with the priority valve closed must not be less than 86 bar (1250 lbf/in²).

9. Slowly open the bleed screw on the pressure gauge pipe and allow the hydraulic system mineral oil to flow into a clean container. Whilst bleeding, observe the pressure gauge needle descending. On reaching a pressure of between 83 bar and 76 bar (1200 lbf/in² and 1100 lbf/in²) the switch lamp should illuminate.

10. If the priority valve/pressure switch operating pressures are not within the above limits the complete unit must be renewed.

11. On completion of the test, top-up the reservoirs to the correct levels with clean hydraulic system mineral oil (see Chapter D).

Priority valve/pressure switches

Introduction

Number 1 system. A priority valve/pressure switch is fitted into the high pressure red line. This priority valve/pressure switch is located on the left-hand underside of the car body, secured to the rear seat heelboard.

Number 2 system. A pressure switch is fitted into the high pressure orange line. On right-hand drive cars the switch is located on the underside of the car body adjacent to a series of connectors. On left-hand drive cars the switch is located on the underside of the car body, adjacent to the distribution valve assembly.

The function of the priority valve is to prevent the flow of hydraulic system mineral oil to the height control valve until a pressure of between 87 bar and 120 bar (1250 lbf/in² and 1750 lbf/in²) is attained in the accumulator. This flow prevention ensures there is sufficient pressure in the hydraulic system to operate the height control mechanism without jeopardising the braking efficiency of the car.

If the pressure in the hydraulic braking system(s) falls unduly while the engine is running, the priority valve will close and isolate the suspension height control mechanism. The reduced hydraulic pressure is then totally utilized for braking purposes.

The pressure switches are actuated by the hydraulic system mineral oil in the hydraulic systems and will illuminate the warning panel(s) situated on the fascia if the pressure in the hydraulic system(s) falls below a safe working pressure. It is therefore important that the switches operate correctly at all times.

In the event of a pressure switch failure within No. 1 system, the complete priority valve/pressure switch must be renewed. Pressure switch failure within No. 2 system requires a new pressure switch.

A priority valve/pressure switch may be overhauled involving the replacement of the 'O' ring and the aluminium washer located on the small end plug.

The dual purpose priority valve/pressure switch is for use with hydraulic system mineral oil only and can be identified by the green outer body. Important

If contamination of the hydraulic system has occurred, overhauling of the unit is essential, and a thorough cleansing of components in Genklene or methylated spirits is of the utmost importance. Also, dry with dry compressed air, not any type of cloth.

Priority valve/pressure switch - To remove (see fig. G11/1-1)

Refer to Section G11 for operational procedures when

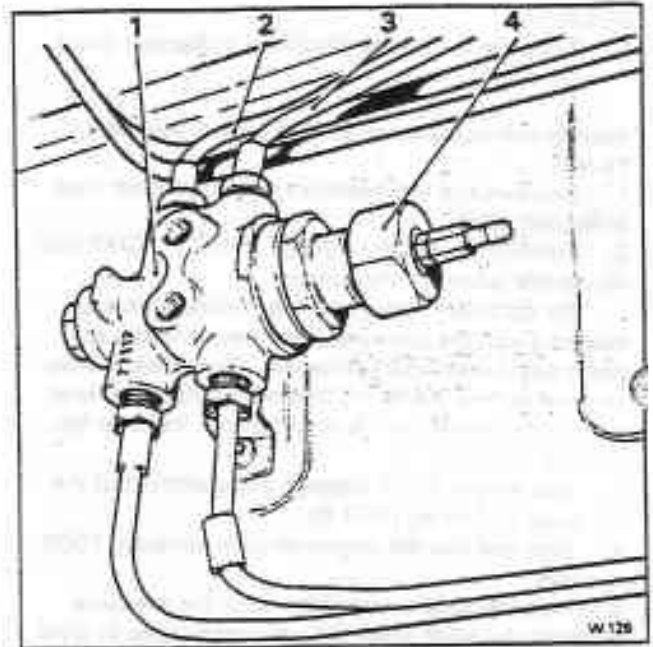

Fig. G11/1-1 Priority valve/pressure switch (No. 1 system)

- 1 Priority valve body
- 2 High pressure line (Red No. 1 system)
- 3 Low pressure line (Black No. 1 system)
- 4 Pressure switch

removal of the priority valve/pressure switch is necessary.

Priority valve/pressure switch - To dismantle (see fig. G11-2)

Refer to Section G11 for operational procedures when dismantling is necessary.

Priority valve/pressure switch - To assemble (see fig. G11-2)

Refer to Section G11 for operational procedures when assembling is necessary.

Priority valve/pressure switch - To fit (see fig. G11/1-1)

Refer to Section G11 for operational procedures when fitting of the unit is necessary.

Pressure switch No. 2 system - To renew (see fig. G11/1-2)

1. Depressurize the hydraulic systems as described in Section G2/1.

G11/1-2

2. Disconnect the electrical connection from the pressure switch.
3. Unscrew the switch from the connector block and discard.
4. Fit a new pressure switch into the connector block and torque/tighten in accordance with the figures in Section G19.
5. Connect the electrical connection to the pressure switch.
6. Bleed the system as described in Section G4/1.

Priority valve/pressure switch (No. 1 system) -

To test

1. Depressurize the hydraulic system as described in Section G2/1.
2. Connect the pressure gauge RH 9727 GMF into the service points of the system.

On right-hand drive cars the service points are located under the left-hand floor area opposite the brake distribution valve assembly. On left-hand drive cars the service points are located on the right-hand side of the car secured to the longeron (refer to figs. G1/1-2 and G4/1-1).

3. Add weight to the luggage compartment of the car equal to 140 kg (300 lb).
4. Start and run the engine at approximately 1000 rev/min.

5. Note the pressure registered on the pressure gauge at the point when the car commences to level.

This pressure must not exceed 120 bar (1750 lbf/in²).

The pressure switch lamp will extinguish before the valve opens and when the maximum pressure has been attained.

6. Switch off the ignition.
7. Attach a bleed pipe to the rear suspension struts bleed screw.

Carefully open the bleed screw, and allow the hydraulic system mineral oil to flow into a clean container until the levelling system is fully exhausted, indicating that the priority valve has closed.

Whilst the pressure is decreasing the priority valve must close before the warning lamp operates.

8. The pressure retained in the braking system and registered on the pressure gauge with the priority valve closed must not be less than 86 bar (1250 lbf/in²).

9. Slowly open the bleed screw on the pressure gauge pipe and allow the hydraulic system mineral oil to flow into a clean container. Whilst bleeding, observe the pressure gauge needle descending. On reaching a pressure of between 83 bar and 76 bar (1200 lbf/in² and 1100 lbf/in²) the lamp should illuminate.

10. If the priority valve/pressure switch operating pressures are not within the above limits the complete unit must be renewed.

11. On completion of the test, top-up the reservoirs to the correct levels with clean hydraulic system mineral oil (see Chapter D).

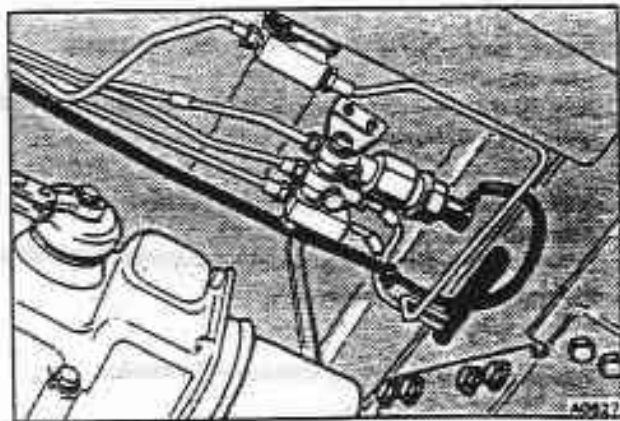

Fig. G11/1-2 Pressure switch (No. 2 system)

Height control valves

Introduction

The height control valves are mounted on the underside of the car body adjacent to each suspension spring.

Actuation of the valves is controlled by pivoting links attached to each trailing arm. Both valves are identical dependent on the type fitted.

The height control valves regulate the flow of hydraulic system mineral oil, either to or from the rear suspension struts, dependent on the variation in load applied to the rear suspension. Any sustained change in the suspension height of the car operates the valves. Under conditions where extra load is applied (i.e. car standing height is low) pressurized hydraulic system mineral oil is allowed to pass from the accumulator, through the height control valves to the rear suspension struts. When the load is reduced (i.e. car standing height is high) the height control valves allow hydraulic system mineral oil to return from the rear suspension struts to the respective system reservoir.

The height control valves are non-serviceable units. In the event of valve malfunction the complete valve assembly must be renewed.

Any error in standing height cannot be corrected by adjustment of the height control valve actuation links.

There are two types of height control valves fitted.

On cars prior to the following vehicle identification numbers (with certain exceptions, see Note) the arrangement shown in figure G12-1 is fitted.

Silver Spirit*SCAZS42A8ECX08170*

Silver Spur*SCAZN42A7DCX08070*

Bentley Mulsanne and Mulsanne Turbo

SCBZSOTO2DCH08080

Corniche/Continental*SCAZD42A5ECX07942*

On cars from vehicle identification numbers quoted, including Bentley Eight, the arrangement shown in figure G12-2 is fitted.

Note

A number of cars with vehicle identification numbers prior to those listed are fitted with the later type of arrangement shown in figure G12-2. Therefore, reference should always be made to figures G12-1 and G12-2 before starting work on the height control valves.

When work is being carried out on the levelling system of the car it should be noted that the height control valves are designed to give a pre-determined delay before they respond to movement of the operating lever. The delay period on the early type of valve (see fig. G12-1) is between 15 seconds and 30 seconds. The delay period on the later type of valve

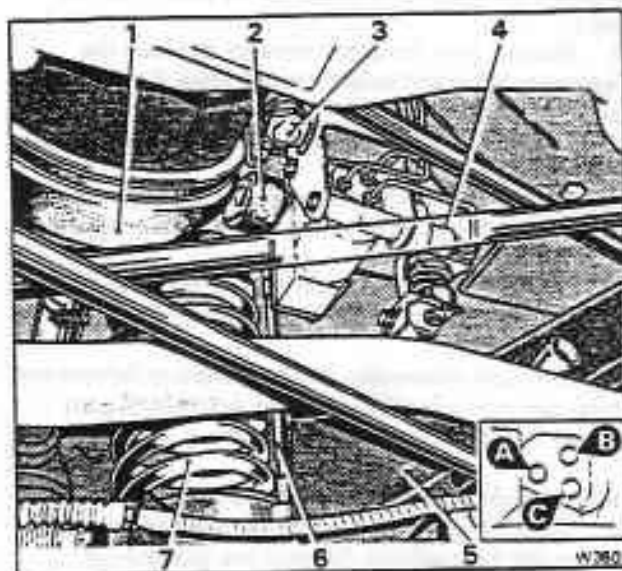

Fig. G12-1 Height control valve (early type)

- 1 Axle drive-shaft
- 2 Height control valve
- 3 Minimum pressure valve
- 4 Restrictor
- 5 Trailing arm
- 6 Height control actuation link
- 7 Rear suspension coil spring
- A Return to reservoir
- B Inlet from priority valve
- C Outlet to minimum pressure valve

(see fig. G12-2) is approximately 7 seconds.

The later type of control valve incorporates a rubber seepage return hose (see fig. G12-2). One end of the hose is connected to the underside of the valve body, the other end to the minimum pressure valve.

This hose arrangement enables designed seepage within the height control valve to return back to the reservoirs.

Height control valve mounting assembly - To remove (see fig. G12-2)

1. Place the car onto a ramp. Engage Park position. Chock the front wheels. Remove the gearchange isolator from the fuseboard.
2. Depressurize the hydraulic system as described in Section G2.
3. Disconnect the valve actuation link from the trailing arm.
4. Disconnect all piping, allowing the unit to be removed from the car. Fit blanks to the pipe ends and ports.

5. Support the unit assembly, remove the three mounting bolts, and collect the spacers (if fitted). Remove the unit from the car.

Height control valve - To remove from the mounting bracket (see fig. G12-2)

1. Remove the height control valve to minimum pressure valve pipe. Fit blanks to the pipe ends and ports.
2. Remove both the pipes situated between the connector block and height control valve. Fit blanks to the pipe ends and ports.
3. Remove the height control valve ball joint from the ball pin.
4. Slacken the clip that secures the seepage return hose to the height control valve. Remove the hose and blank the hose end.
5. Unscrew the height control valve securing bolts, remove the valve from the bracket assembly.

Note

On right-hand assemblies it is necessary to remove the minimum pressure valve from the brackets to gain access to the bolts securing the valve.

Height control valve - To remove (see fig. G12-1)

1. Place the car onto a ramp. Engage Park position. Chock the front wheels. Remove the gearchange isolator from the fuseboard.

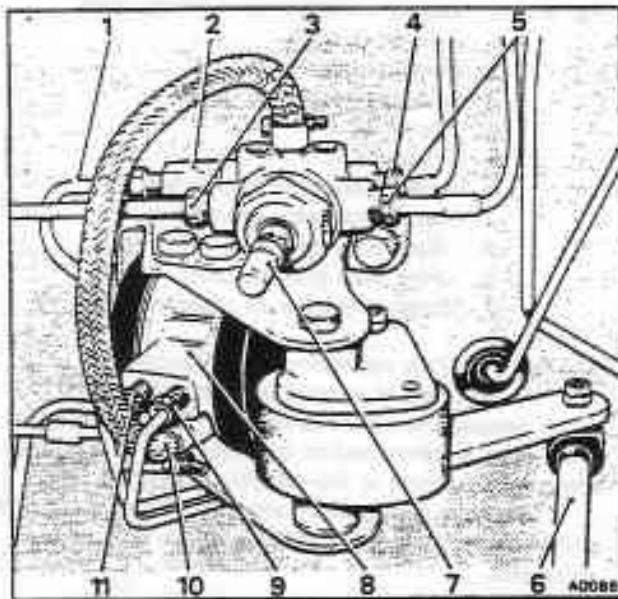

Fig. G12-2 Height control valve (later type)

- 1 High pressure feed
- 2 Restrictor
- 3 Low pressure return
- 4 High pressure feed
- 5 Low pressure return
- 6 Actuation link return
- 7 Domed nut - adjuster
- 8 Height control valve
- 9 Low pressure return
- 10 Hose - seepage return
- 11 High pressure feed

2. Depressurize the hydraulic system as described in Section G2.

3. Disconnect the valve actuation link from the trailing arm.
4. Remove the three pipe connections from the valve assembly; fit blanks to the pipe ends and valve ports.
5. Remove the valve mounting bolts. Lower the valve from its mounting bracket.
6. Remove the valve actuation link from the operating arm.

Height control valve - To fit (see fig. G12-2)

Fit the height control valve by reversing the procedure given for removal noting the following.

1. When fitting a new height control levelling valve, ensure that the new valve is charged with new hydraulic system mineral oil.
2. After positioning the valve into its mounting bracket torque tighten the securing screws to the figures given in Section G19.
3. Fit new sealing sleeves to all pipe connections.
4. All setscrews and pipe connections should be torque tightened in accordance with figures quoted in Section G19 and Chapter P.
5. Prior to fitting the height control seepage return hose, fill the hose with new hydraulic system mineral oil.
6. Grease the ball joint, connect to the ball pin, adjust to give free play ensuring freedom of movement.

Height control valve mounting assembly - To fit (see fig. G12-2)

Fit the assembled unit to the car by reversing the procedure noting the following

1. All pipe connections and bolts should be torque tightened in accordance with the figures quoted in Section G19 and Chapter P.
2. After fitting a height control valve the hydraulic system must be bled as described in Section G4.

Height control valve - To fit (see fig. G12-1)

Fit the height control valve by reversing the procedure for removal noting the following.

1. All setscrews and pipe connections should be torque tightened in accordance with the figures quoted in Section G19 and Chapter P.
2. After fitting a height control valve the hydraulic system must be bled as described in Section G4.

Height control valve links - To set

1. Check that the fuel tank is full. However, if the tank is partially empty, weight equivalent to the amount of missing fuel should be positioned adjacent to the fuel tank. For each 4.5 litres (1 Imp gal, 1.2 US gal) of missing fuel add 3.4 kg (7.5 lb) of weight.
2. Ensure that the spare wheel, jack, tools and accessories are fitted in their relevant positions.
3. Check the tyre pressures and adjust accordingly.

Height control valves

Introduction

The height control valves are mounted on the underside of the car body adjacent to each suspension spring.

Actuation of the valves is controlled by pivoting links attached to each trailing arm. Both valves are identical dependent on the type fitted.

The height control valves regulate the flow of hydraulic system mineral oil, either to or from the rear suspension struts, dependent on the variation in load applied to the rear suspension. Any sustained change in the suspension height of the car operates the valves. Under conditions where extra load is applied (i.e. car ride height is low) pressurized hydraulic system mineral oil is allowed to pass from the accumulator, through the height control valves to the rear suspension struts. When the load is reduced (i.e. car ride height is high) the height control valves allow hydraulic system mineral oil to return from the rear suspension struts to the respective system reservoir.

The height control valves are non-serviceable units. In the event of valve malfunction the complete valve assembly must be renewed.

Any error in ride height cannot be corrected by adjustment of the height control valve actuation links.

There are two types of height control valves fitted.

On cars prior to the following vehicle identification numbers (with certain exceptions, see Note) the arrangement shown in figure G12-1 is fitted.

Silver Spirit *SCAZS42A8ECX08170*

Silver Spur *SCAZN42A7DCX08070*

Bentley Mulsanne and Mulsanne Turbo

SCBZS0T02DCH08080

Corniche/Continental *SCAZD42A5ECX07942*

On cars from vehicle identification numbers quoted, including Bentley Eight, the arrangement shown in figure G12-2 is fitted.

Note

A number of cars with vehicle identification numbers prior to those listed are fitted with the later type of arrangement shown in figure G12-2. Therefore, reference should always be made to figures G12-1 and G12-2 before starting work on the height control valves.

When work is being carried out on the levelling system of the car it should be noted that the height control valves are designed to give a pre-determined delay before they respond to movement of the operating lever. The delay period on the early type of valve (see fig. G12-1) is between 15 seconds and 30 seconds. The delay period on the later type of valve (see fig. G12-2) is approximately 7 seconds.

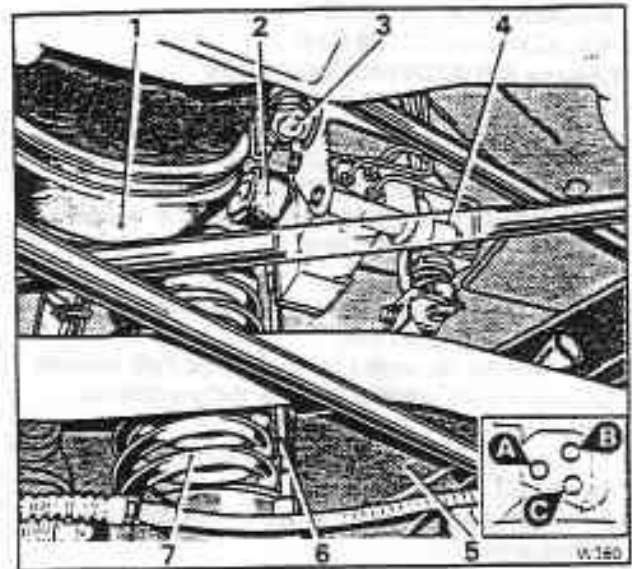

Fig. G12-1 Height control valve (early type)

- 1 Axle drive-shaft
- 2 Height control valve
- 3 Minimum pressure valve
- 4 Restrictor
- 5 Trailing arm
- 6 Height control actuation link
- 7 Rear suspension coil spring
- A Return to reservoir
- B Inlet from priority valve
- C Outlet to minimum pressure valve

The later type of control valve incorporates a rubber seepage return hose (see fig. G12-2). One end of the hose is connected to the underside of the valve body, the other end to the minimum pressure valve.

This hose arrangement enables designed seepage within the height control valve to return back to the reservoirs.

On cars from the following vehicle identification numbers (VIN), small bore pipes between the height control valve and the minimum pressure valve, together with an in-line hydraulic filter have been introduced. The pipes have an internal bore diameter of 0.76 mm (0.030 in), the purpose of which is to reduce the rate of flow of mineral oil between the height control valve and the strut.

In order to prevent any foreign matter entering the pipe from the strut or gas spring, the in-line filter replaces the connector block which was formerly located in the strut feed pipe, adjacent to the strut tower (see fig. G15-2).

Silver Spirit * SCAZS42AXFCX12755 * including
 * SCAZS0005FCX12617 *
 * SCAZS0005FCH12653 *
 * SCAZS0002FCH12710 *
 * SCAZS0005FCH12748 *
 * SCAZS0000FCX12749 *

Silver Spur * SCAZN42A8FCX12860 * including
 * SCAZN000XFCX12779 *
 * SCAZN42A4FCX12810 *

Corniche * SCAZD42A0FCX10314 *

Continental * SCBZD0001FCH10324 *

Bentley Mulsanne * SCBZS0002FCH12797 *

Bentley Mulsanne L * SCBZN42A3FCX13085 *

Mulsanne Turbo * SCBZS0T05FCH12580 *

Bentley Eight * SCBZS8008FCX12783 * including
 * SCBZS8005FCX12739 *

Height control valve mounting assembly - To remove (see fig. G12-2)

1. Place the car onto a ramp. Engage Park position. Chock the front wheels. Remove the gearchange isolator from the fuseboard.
2. Depressurize the hydraulic system as described in Section G2.
3. Disconnect the valve actuation link from the trailing arm.

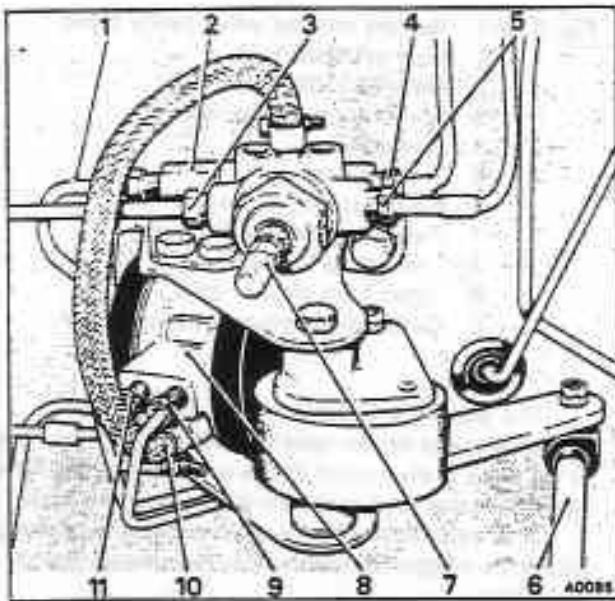

Fig. G12-2 Height control valve (later type)

- 1 High pressure feed
- 2 Restrictor
- 3 Low pressure return
- 4 High pressure feed
- 5 Low pressure return
- 6 Actuation link return
- 7 Domed nut - adjuster
- 8 Height control valve
- 9 Low pressure return
- 10 Hose - seepage return
- 11 High pressure feed

4. Disconnect all piping, allowing the unit to be removed from the car. Fit blanks to the pipe ends and ports.
5. Support the unit assembly, remove the three mounting bolts, and collect the spacers (if fitted). Remove the unit from the car.

Height control valve - To remove from the mounting bracket (see fig. G12-2)

1. Remove the height control valve to minimum pressure valve pipe. Fit blanks to the pipe ends and ports.
2. Remove both the pipes situated between the connector block and height control valve. Fit blanks to the pipe ends and ports.
3. Remove the height control valve ball joint from the ball pin.
4. Slacken the clip that secures the seepage return hose to the height control valve. Remove the hose and blank the hose end.
5. Unscrew the height control valve securing bolts, remove the valve from the bracket assembly.

Note

On right-hand assemblies it is necessary to remove the minimum pressure valve from the brackets to gain access to the bolts securing the valve.

Height control valve - To remove (see fig. G12-1)

1. Place the car onto a ramp. Engage Park position. Chock the front wheels. Remove the gearchange isolator from the fuseboard.
2. Depressurize the hydraulic system as described in Section G2.
3. Disconnect the valve actuation link from the trailing arm.
4. Remove the three pipe connections from the valve assembly; fit blanks to the pipe ends and valve ports.
5. Remove the valve mounting bolts. Lower the valve from its mounting bracket.
6. Remove the valve actuation link from the operating arm.

Height control valve - To fit (see fig. G12-2)

Fit the height control valve by reversing the procedure given for removal noting the following.

1. When fitting a new height control levelling valve, ensure that the new valve is charged with new hydraulic system mineral oil.
2. After positioning the valve into its mounting bracket torque tighten the securing screws to the figures given in Section G19.
3. Fit new sealing sleeves to all pipe connections.
4. All setscrews and pipe connections should be torque tightened in accordance with figures quoted in Section G19 and Chapter P.
5. Prior to fitting the height control seepage return hose, fill the hose with new hydraulic system mineral oil.
6. Grease the ball joint, connect to the ball pin, adjust to give free play ensuring freedom of movement.

Height control valve mounting assembly - To fit (see fig. G12-2)

Fit the assembled unit to the car by reversing the procedure noting the following.

1. All pipe connections and bolts should be torque tightened in accordance with the figures quoted in Section G19 and Chapter P.
2. After fitting a height control valve the hydraulic system must be bled as described in Section G4.

Height control valve - To fit (see fig. G12-1)

Fit the height control valve by reversing the procedure for removal noting the following.

1. All setscrews and pipe connections should be torque tightened in accordance with the figures quoted in Section G19 and Chapter P.
2. After fitting a height control valve the hydraulic system must be bled as described in Section G4.

Height control valve links - To set

1. Check that the fuel tank is full. However, if the tank is partially empty, weight equivalent to the amount of missing fuel should be positioned adjacent to the fuel tank. For each 4,5 litres (1 Imp gal, 1.2 US gal) of missing fuel add 3,4 kg (7.5 lb) of weight.
2. Ensure that the spare wheel, jack, tools and accessories are fitted in their relevant positions.
3. Check the tyre pressures and adjust accordingly.
4. Drive the car onto a suitable level ramp. Check the front road wheels.
5. Move the gear range selector lever to the Neutral position. Remove the gearchange isolator from the fuseboard and release the parking brake.
6. Depressurize by opening the bleed screws on the accumulators, allowing sufficient time for the mineral oil pressure to discharge back to the reservoirs.
7. Remove the strut bleed screws and fit pressure gauges, part number RH 9727 GMF.
8. Start the engine, allow the hydraulic system to fully pressurize (allow four minutes).
9. Bleed the struts.
10. Disconnect the actuation links.
11. Manually operate the actuation links, raising equal amounts. Check that there is a delay before the car begins to rise and that the car rises smoothly. Allow the car to rise until approximately 34,5 bar (500 lbf/in²) registers on the pressure gauge.
12. Slowly pull both links down simultaneously to the lowered position. Check that there is a delay before the car commences to descend.
13. Allow the car to settle at the fully lowered position. Pull down on the rear bumper to ensure that the car has fully settled. Release the bumper.
14. Check that the minimum pressure valve(s) setting pressure complies with the figures quoted in the chart (see Section G14).
15. With the height control links disconnected, fit the location setting pins into the height control levers (see fig. G12-3).
16. Adjust the links until they neatly fit onto the ball joints. Grease the ball pins, adjust to remove free play

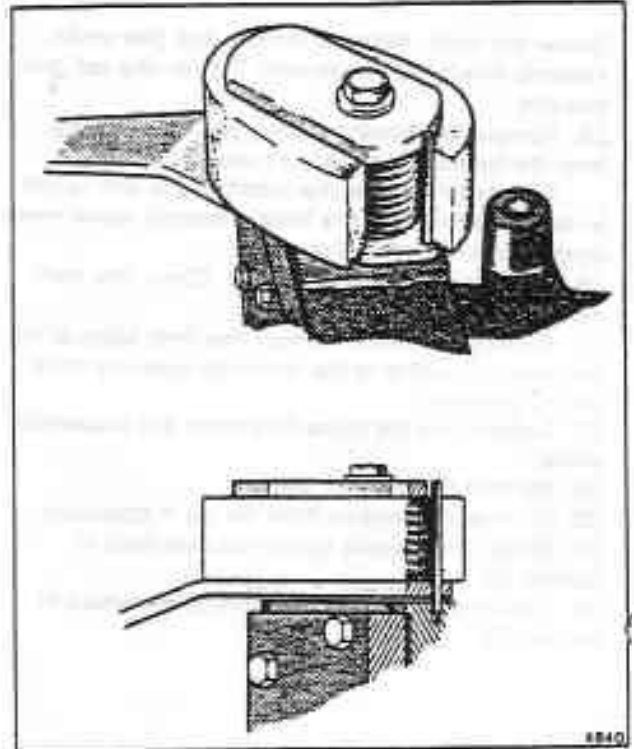

Fig. G12-3 Height control valve actuation arm location pin

whilst ensuring freedom of movement. Tighten the ball joint lock-nut.

17. On cars that have adjustable minimum pressure valves (see fig. G12-2) the valves can be adjusted by carrying out the following procedure, setting the pressure to within the required specification.
18. Remove the domed nut (see fig. G12-2) exposing the adjuster screw. Slacken the lock-nut.
19. Turn the adjuster screw either clockwise or anti-clockwise, depending on whether the pressure requires increasing or decreasing. A quarter (1/4) turn of the adjuster screw alters the pressure by approximately 7 bar (100 lbf/in²).
20. After making an adjustment to the pressure setting carry out operations 11, 12, and 13.
21. Tighten the lock-nut and replace the domed nut.
22. Raise both links slowly until the pressure gauge needles commence to move. At this point immediately pull both links down sufficiently to stop the needles moving. The height control valves are now in the neutral position.
23. On cars fitted with the later type of height control valve (see fig. G12-2) slacken the ball pin retaining nut on the trailing arms. Slide the ball pin up or down to a position where the actuation link ball joint fits neatly onto the ball pin. Adjust to remove free play whilst ensuring freedom of movement. Tighten the ball joint lock-nuts.
24. On cars fitted with the early type of height control valve (see fig. G12-1) adjust the links until the ball joint fits neatly onto the ball pins on the trailing arms.

Grease the joints, adjust to remove free play whilst ensuring freedom of movement. Tighten the ball joint lock-nut.

25. Remove the location setting pin (where fitted) from the height control valves (see fig. G12-3).

Failure to remove the location pin will result in severe damage to the height control valve when suspension movement occurs.

26. Pull down on the rear bumper. Check that both sides of the car rise smoothly.

27. Release the bumper. Check that both sides of the car lowers smoothly to the minimum pressure valve setting pressure.

28. Depressurize the hydraulic system and suspension struts.

29. Remove the pressure gauges.

30. Remove the weights from the car if applicable.

31. Bleed the hydraulic system as described in Section G4.

32. Top-up and seal the reservoirs as described in Section G5.

Restrictor - height control valve/minimum pressure valve

Introduction

A restrictor is situated into each high pressure system as shown in figures G1-1 to G1-9 inclusive.

The function of a restrictor is to allow a constant amount of hydraulic system mineral oil to flow through the system.

The restrictors are situated either: one adjacent to each height control valve (see fig. G1-1), or one secured into each minimum pressure valve (see fig. G1-8).

Restrictor fitted adjacent to the height control valve - To remove

The restrictor mounted onto the right-hand height control levelling valve bracket is fitted into the number 1 high pressure system. The restrictor mounted onto the left-hand bracket is fitted into the number 2 high pressure system.

1. Depressurize the system as described in Section G2.
2. Disconnect the hydraulic pipes from the restrictor and blank off the pipe ends.
3. Release the restrictor from its mounting bracket.

Restrictor fitted adjacent to the height control valve - To dismantle (see fig. G13-1)

1. Remove the plug from the restrictor body.
2. Invert the restrictor valve body, collect the sealing ring restrictor plate, roller, and end plates.
3. Thoroughly clean all components with either Genklene or methylated spirits. Dry with clean compressed air. Do not use any type of cloth.

Restrictor fitted adjacent to the height control valve - To assemble

Assemble the restrictor by reversing the dismantling procedure noting the following.

1. All components must be thoroughly cleaned before assembly.
2. Ensure that the roller moves freely in the restrictor plate bore prior to fitting into the valve body.
3. Fit a new sealing ring if necessary.
4. Lightly smear the threads of the plug with Rocol MTS 1000 grease or a suitable equivalent prior to fitting.
5. Torque tighten the plug in accordance with the figures quoted in Section G19.

Restrictor fitted adjacent to the height control valve - To fit

Fit the restrictor by reversing the procedure given for removal noting the following.

1. Torque tighten the securing nut and bolt, and the

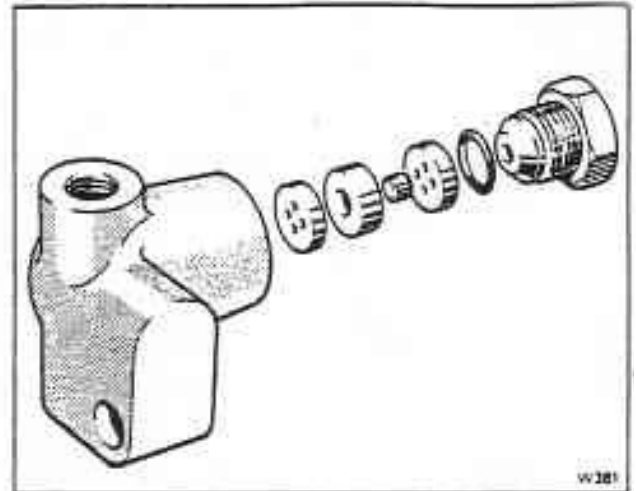

Fig. G13-1 Restrictor - height control valve

pipe connections in accordance with the figures quoted in Section G19 and Chapter P.

2. After fitting, bleed the hydraulic system as described in Section G4.

Restrictor screwed into the minimum pressure valve - To renew (see figs. G14-2 and G14-3)

The restrictor screwed into the right-hand minimum pressure is fitted into the number 1 high pressure system. The restrictor screwed into the left-hand minimum pressure valve is fitted into the number 2 high pressure system.

1. Depressurize the systems as described in Section G2.
2. Disconnect the hydraulic pipe from the restrictor and blank off the pipe.
3. Remove the restrictor from the minimum pressure valve, discard the sealing ring. Blank off the port from which the restrictor has been removed.
4. Inspect the restrictor, renew if necessary.
5. Obtain a new sealing ring. Thoroughly clean all the components with either Genklene or methylated spirits. Dry with clean compressed air. Do not use any type of cloth.
6. Fit the washer and restrictor to the minimum pressure valve. Connect the hydraulic pipe to the restrictor. Torque tighten in accordance with the figures quoted in Section G19.
7. After fitting, bleed the hydraulic system as described in Section G4.

Restrictors, one-way valve, and filter

Introduction (see figs. G1/1-1, G1/1-2, and G1/1-3)

Two restrictors are situated in the No.1 system high pressure line to the rear suspension struts. A restrictor is also fitted into each brake line.

The function of a restrictor is to reduce the flow of hydraulic system mineral oil under certain operating conditions.

A one-way valve is incorporated in the No.1 system left-hand height control valve high pressure exhaust line. The one-way valve is necessary to protect the left-hand height control valve against pressurized fluid from the right-hand height control valve entering the exhaust port. Thereby, preventing damage to the left-hand height control valve.

Under conditions where the suspension is levelling in the upward mode, the one-way valve prevents high pressure fluid from the right-hand height control valve entering the exhaust port of the left-hand height control valve. With the suspension levelling in the downward mode, the one-way valve allows the returning fluid from both suspension struts to pass through both levelling valves.

A filter is incorporated in the No.1 system high pressure line, positioned between the accumulator and priority valve/pressure switch. Its function being, to ensure that any foreign matter does not proceed into the system.

Restrictor - To renew

1. Depressurize the system as described in Section G2/1.
2. Disconnect the hydraulic pipes from the restrictor and blank off the pipes. Discard the sealing ring.
3. Inspect the restrictors. Renew if necessary.
4. Thoroughly clean the components with either Genklene or methylated spirits. Dry with clean compressed air. Do not use any type of cloth. Fit a new sealing ring.
5. Fit the washer and restrictor. Connect the hydraulic pipes. Torque tighten in accordance with the figures quoted in Section G19. Ensure that the correct restrictor is fitted.
6. Bleed the hydraulic system as described in Section G4/1.

One-way valve - To renew (see fig. G13/1-1)

1. Depressurize the system as described in Section G2/1.
2. Disconnect the hydraulic pipes from the valve and blank off the pipes. Discard the sealing ring.
3. Unscrew the securing bolt and remove the valve from the car.

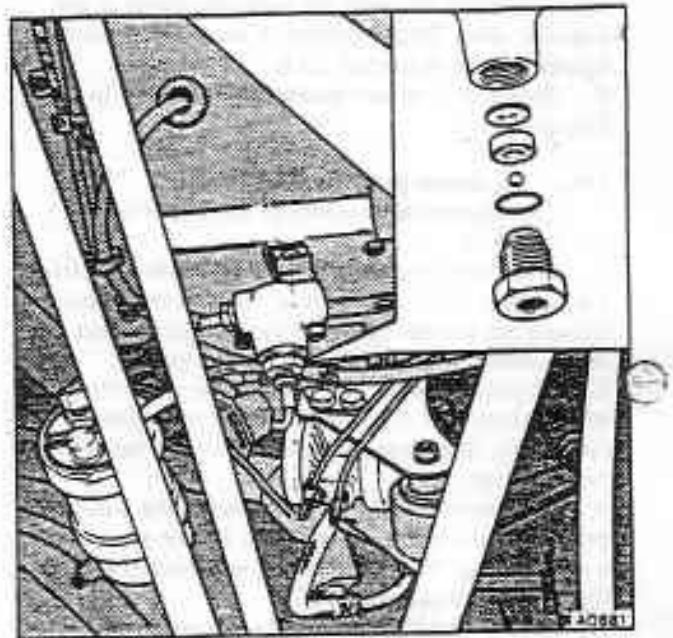

Fig. G13/1-1 One-way valve

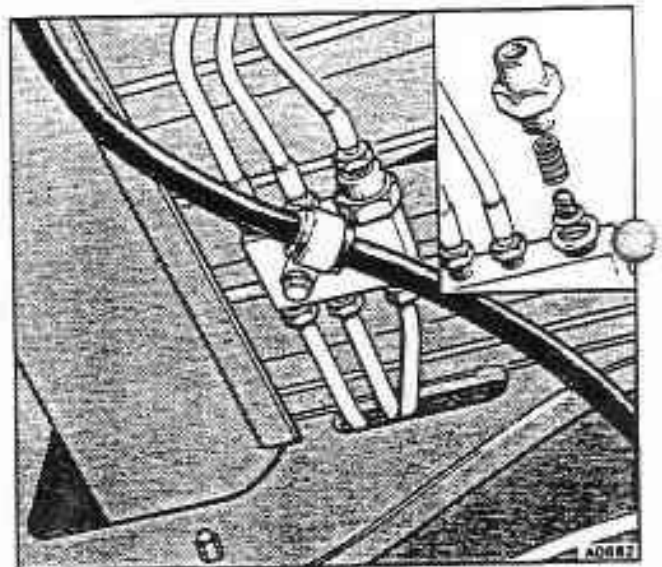

Fig. G13/1-2 Filter - Adapter

4. Unscrew and remove the union. Dismantle the components. Discard the sealing ring.
5. Thoroughly clean all components with either Genklene or methylated spirits. Dry with clean compressed air. Do not use any type of cloth.

6. Using a new sealing ring assemble the components. Torque tighten the union in accordance with the figures quoted in Section G19. Blank off the ports.
7. Position the one-way valve onto the car. Secure in place, torque tightening in accordance with the figures quoted in Chapter P.
8. Remove the blanks from the valve ports and the hydraulic pipes. Connect the hydraulic pipes to the one-way valve. Torque tighten in accordance with the figures quoted in Section G19.
9. Bleed the hydraulic system as described in Section G4/1.

Filter - To renew (see fig. G13/1-2)

1. Depressurize the system as described in Section G2/1.
2. Disconnect the No.1 system hydraulic pipe from the adapter. Blank off the pipe. Remove the adapter. Discard the washer. Carefully remove and collect the components. Blank off the port in the block.
3. Obtain a new washer. Thoroughly clean the components with either Genklene or methylated spirits. Dry with clean compressed air. Do not use any type of cloth.
4. Remove the blank from the port in the connector block. Assemble the components. Fit the adapter with a new washer. Torque tighten in accordance with the figures quoted in Section G19.
5. Remove the blanks from the hydraulic pipe. Connect the hydraulic pipe to the adapter. Torque tighten in accordance with the figures quoted in Section G19.

Minimum pressure valve

Introduction

On cars other than Bentley Turbo R, a minimum pressure valve is incorporated into each hydraulic system, situated between the height control valve and the suspension strut.

Each valve is mounted behind its respective height control valve.

On Bentley Turbo R models there is only one minimum pressure valve fitted. This is incorporated into the No. 1 high pressure system situated between the height control valve and the suspension struts.

The purpose of the valve(s) is to retain a pre-determined hydraulic pressure in the suspension strut(s).

During normal system operation, the minimum pressure valve is held in the open position by hydraulic system pressure. This allows the uninterrupted flow of hydraulic system mineral oil between the height control valve and the suspension strut(s).

However, if the supply of hydraulic system mineral oil to the suspension strut(s) falls below a pre-determined pressure the minimum pressure valve will close and isolate the suspension strut(s) from the system.

It is important that the minimum pressure valve setting pressures are within the specifications listed, in conjunction with the correct vehicle identification number range, as the combination of road springs, adjusting shims, and suspension strut pressures are governed by the accuracy of the minimum pressure valve. A chart listing the acceptable pressures and height measurements can be found at the end of this section.

On cars from the following vehicle identification numbers an adjustable minimum pressure valve, in conjunction with a new height control valve arrangement was introduced (see figs. G12-2 and G14-2). However, there are a small number of cars that have this arrangement fitted prior to the numbers listed. Furthermore, there are cars that have the non-adjustable minimum pressure valve fitted (see fig. G14-1) with the latest height control valve (see fig. G12-2).

Silver Spirit *SCAZS42A8ECX08170*

Silver Spur *SCAZN42A7DCX08070*

Bentley Mulsanne and Mulsanne Turbo

SCAZS0T02DCH08080

Corniche/Continental

SCAZD42A5ECX07942

Bentley Turbo R incorporates the adjustable minimum pressure valve with an adapter.

As there are a number of different minimum pressure valve setting pressures on cars in service, an

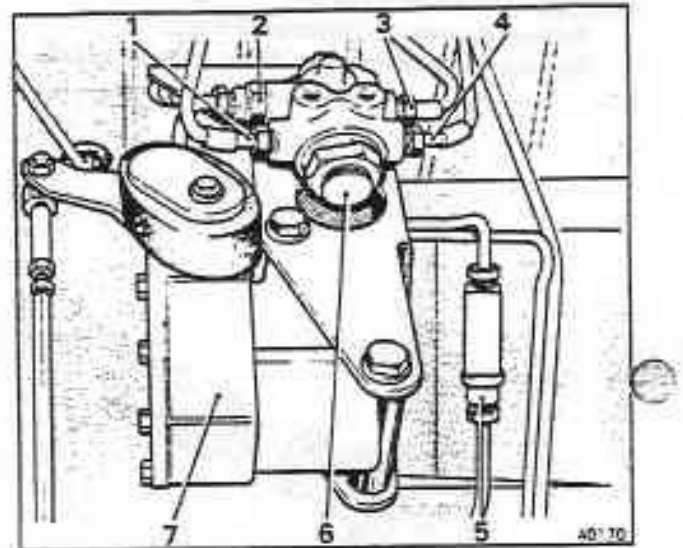

Fig. G14-1 Minimum pressure valve

- 1 Seepage return pipe from suspension strut
- 2 Supply pipe from height control valve
- 3 Supply pipe to suspension strut
- 4 Seepage return pipe to reservoir
- 5 Filter/restrictor
- 6 Minimum pressure valve.
- 7 Height control valve

adjustable minimum pressure valve enables the individual valve to be set without removing the unit from the car.

A seepage return hose has been introduced and is fitted between the minimum pressure valve and the underside of the height control valve body (see figs. G12-2 and G12/1-1).

Minimum pressure valve - To remove (see fig. G14-1)

1. Depressurize the hydraulic system as described in Section G2.
2. Disconnect the pipe connections from the minimum pressure valve. Blank off all pipe ends and valve ports.
3. Unscrew the mounting bolts, collect the washers. Remove the minimum pressure valve.

Minimum pressure valve - To remove (see figs. G12-2 and G12/1-2)

1. Remove the height control valve arrangement as described in Section G12, Height control valve mounting assembly - To remove.

2. Disconnect all pipe connections from the minimum pressure valve. Blank off all pipe ends and valve ports.
3. Unscrew the setscrews and remove the minimum pressure valve from the bracket. Retain the setscrews and washers.

Minimum pressure valve - To dismantle
(see figs. G14-2 and G14-3)

1. Remove the adapter/restrictor (if fitted).
2. Remove the large end cap, taking care not to lose

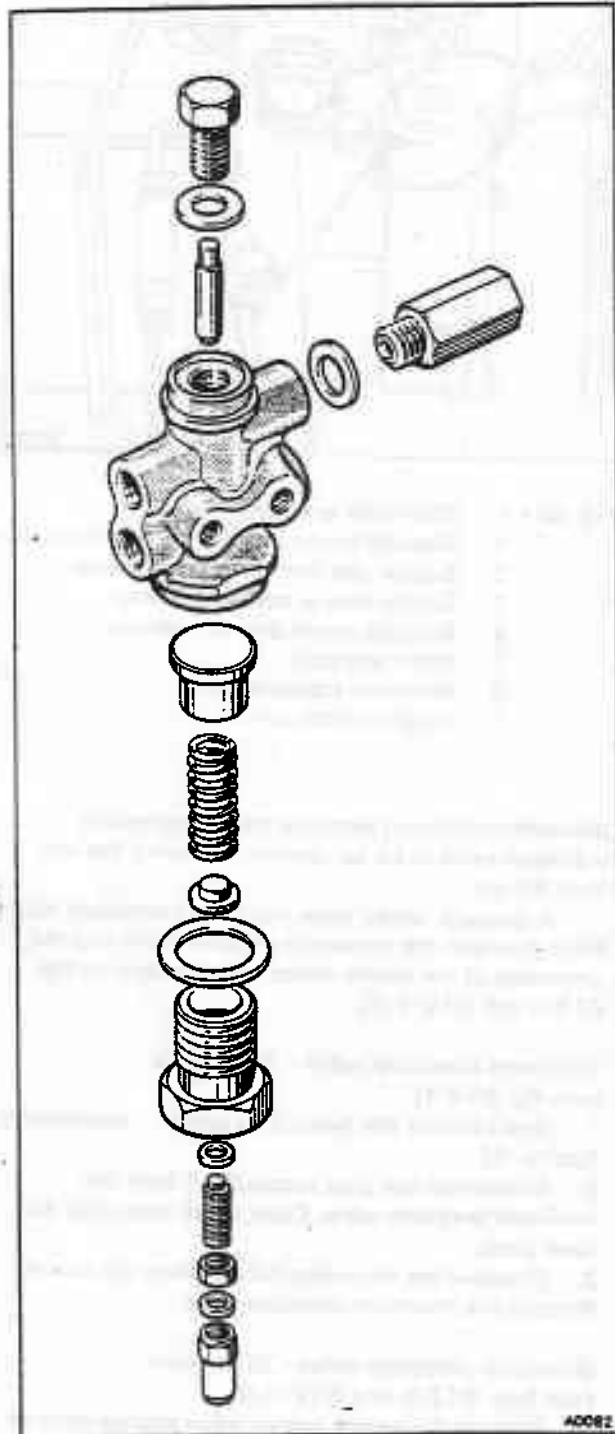

Fig. G14-2 Minimum pressure valve with adjuster

any shims from beneath the spring. Remove the spring cup and seat (if fitted).

3. Remove the small end plug.
4. Remove the plunger from the valve housing. It may be necessary to use air pressure applied through the inlet port to blow out the valve.
5. Remove the adjuster from the large end cap (see fig. G14-2). Retain the adjuster screw, lock-nut, and domed end nut.
6. Thoroughly clean all components with Genkylene or methylated spirits. Dry with clean compressed air. Do not use any type of cloth.

Minimum pressure valve - To assemble
(see figs. G14-2 and G14-3)

Assemble the minimum pressure valve by reversing the procedure for dismantling noting the following.

1. Ensure that the plunger valve is fitted with the longer shoulder towards the small end plug.
2. Fit the adapter/restrictor if applicable.
3. Fit new sealing washers.
4. Torque tighten in accordance with the figures quoted in Section G19.

Minimum pressure valve - To fit (see figs. G14-1 and G14-3)

1. Fit the minimum pressure valve into position and secure with setscrews and washers.
2. Remove the blanks and connect the pipes.
3. Torque tighten all bolts and pipe connections to the figures quoted in Section G19 and Chapter P.
4. Bleed the hydraulic system as described in Section G4.

Minimum pressure valve - To fit (see figs. G12-2 and G14-2)

1. Fit the minimum pressure valve onto the bracket and secure in position.
2. Remove the blanks and connect the pipe located between the minimum pressure valve and the height control valve.
3. Fill the seepage return hose with new hydraulic system mineral oil and secure the hose into position between the minimum pressure valve and the underside of the height control valve body.
4. Fit the assembled unit as described in Section G12, Height control valve mounting assembly - To fit.
5. Bleed the hydraulic system as described in Sections G4 and G4/1.
6. Torque tighten all bolts and pipe connections to the figures quoted in Section G19 and Chapter P.

Minimum pressure valves - To test

Before commencing setting procedures on the minimum pressure valves, ensure that the cars standing height is correct in accordance with the figures quoted in Chapter H.

1. Depressurize the hydraulic system as described in Sections G2 and G2/1.
2. Remove the suspension struts bleed screw. Connect a pressure gauge RH9727 GMF into the bleed screw adapters.

3. Ensure that the gearchange selector is in the Park position and that the gearchange thermal cut-out is removed from the fuseboard. Start the engine.
4. Disconnect both height control valve links at the bell joints on the trailing arms.
5. Lift both height control valve links approximately 25,4 mm (1.0 in) and allow the strut pressures to rise to 34,5 bar (500 lbf/in²).

Note

There should be a delay before the car starts to level after raising the control valve links. This delay can vary with different cars and variations in engine speed. It may take up to two minutes for the pressure to reach 34,5 bar (500 lbf/in²).

6. Slowly pull down both control valve links approximately 25,4 mm (1.0 in) to exhaust the hydraulic pressure from the rear suspension struts. Allow 3 minutes for the car to stabilize.

7. With the height control systems exhausted, the minimum pressure valves should retain a pressure in accordance with the figures quoted in the chart on pages G14-4 and G14-5.

Allow the pressure to stabilize for 1 minute after the minimum pressure valve closes before noting the pressure.

The actual retained pressure will be registered on the pressure gauges inserted at the bleed connections. Should the retained pressure be outside the above limits, the faulty valve(s) should be renewed, or suitably adjusted.

8. Connect the actuation links at the trailing arm. Ensure that freedom of movement is present.
9. Depressurize the system as described in Sections G2 and G2/1.
10. Remove the pressure gauge(s). Fit bleedscrews.
11. Bleed the hydraulic system as described in Sections G4 and G4/1.
12. Top-up and re-seal reservoirs as described in Sections G5 and G5/1.

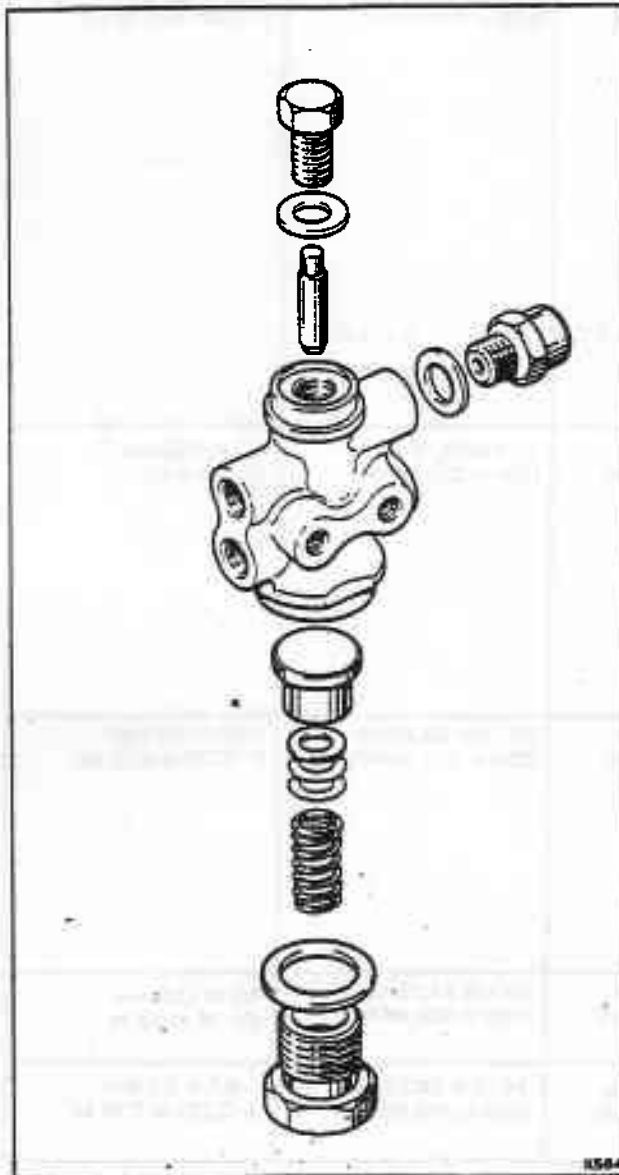

Fig. G14-3 Minimum pressure valve

Car type	Vehicle identification number	Gas spring pressure	Minimum pressure valve setting pressure	Rear suspension height
Silver Spirit	From *SCAZS0000ACH01001* to *SCAZS0006DCH06969* including *SCAZS0006DCX07004* *SCAZS0008DCX07005* *SCAZS0008DCX07022* *SCAZS000XDCX07023* *SCAZS0003DCX07025* excluding *SCAZS42A9DCX06572* *SCAZS0005DCJ06882* *SCAZS0004DCX06921* *SCAZS0007DCH06950* *SCAZS0000DCH06952* *SCAZS0004DCH06954* *SCAZS0008DCH06956* *SCAZS0001DCH06958* *SCAZS000XDCX06960* *SCAZS0003DCH06962*	10.35 to 16.0 bar (150 to 232 lbf/in ²)	20.7 to 24.15 bar (300 to 350 lbf/in ²)	4.5 to 12.5 mm (0.175 to 0.5 in)
Silver Spirit	From *SCAZS0002DCH06970* onwards, including *SCAZS42A9DCX06572* *SCAZS0005DCH06882* *SCAZS0004DCX06921* *SCAZS0007DCH06950* *SCAZS0000DCH06952* *SCAZS0004DCH06954* *SCAZS0008DCH06956* *SCAZS0001DCH06958* *SCAZS000XDCX06960* *SCAZS0003DCH06962* excluding *SCAZS0006DCX07004* *SCAZS0008DCX07005* *SCAZS0008DCX07022* *SCAZS000XDCX07023* *SCAZS0003DCX07025*	10.35 to 18.63 bar (150 to 270 lbf/in ²)	24.15 to 26.22 bar (350 to 380 lbf/in ²)	- 5.5 to 2.5 mm (- 0.225 to 0.10 in)
Silver Spur	From *SCAZN0000ACH01006* to *SCAZN42A6DCX06844* including *SCAZN0008DCH06852* *SCAZL0007DCH06993* *SCAZN0006DCH06994* excluding *SCAZN0001DCX06656* *SCAZN000XDCX06786* *SCAZN0003DCH06791* *SCAZN0002DCX06794*	10.35 to 16.0 bar (150 to 232 lbf/in ²)	20.7 to 24.15 bar (300 to 350 lbf/in ²)	4.5 to 12.5 mm (0.175 to 0.5 in)
Silver Spur	From *SCAZN0004DCX06845* onwards, including *SCAZN0001DCX06656* *SCAZN000XDCX06786* *SCAZN0003DCH06791* *SCAZN0002DCX06794* excluding *SCAZN0008DCH06852* *SCAZL0007DCH06993* *SCAZN0006DCH06994*	10.35 to 18.63 bar (150 to 270 lbf/in ²)	24.15 to 26.22 bar (350 to 380 lbf/in ²)	- 5.5 to 2.5 mm (- 0.225 to 0.10 in)
Bentley Mulsanne	From *SCBZS0000ACH01009* to *SCBZS0004DCH06917*	10.35 to 16.0 bar (150 to 232 lbf/in ²)	20.7 to 24.15 bar (300 to 350 lbf/in ²)	4.5 to 12.5 mm (0.175 to 0.5 in)
Bentley Mulsanne	From *SCBZS0003DCH07007* onwards	10.35 to 18.63 bar (150 to 270 lbf/in ²)	24.15 to 26.22 bar (350 to 380 lbf/in ²)	- 5.5 to 2.5 mm (- 0.225 to 0.10 in)

Car type	Vehicle identification number	Gas spring pressure	Minimum pressure valve setting pressure	Rear suspension height
Mulsanne Turbo	From *SCBZSOT05CCH04233* to *SCBZSOT09DCX06906* including *SCBZSOT06DCH06977* *SCBZSOT0XDCX07059* excluding *SCBZSOT01DCX06639* *SCBZSOT01DCX06642* *SCBZSOT06DCH06803* *SCBZSOT0XDCX06867* *SCBZSOT08DCH06872*	10,35 to 16,0 bar (150 to 232 lbf/in ²)	20,7 to 24,15 bar (300 to 350 lbf/in ²)	4,5 to 12,5 mm (0.175 to 0.5 in)
Mulsanne Turbo	From *SCBZSOT00DCX06907* onwards, including *SCBZSOT01DCX06639* *SCBZSOT01DCX06642* *SCBZSOT06DCH06803* *SCBZSOT0XDCX06867* *SCBZSOT08DCH06872* excluding *SCBZSOT06DCH06977* *SCBZSOT0XDCX07059*	10,35 to 18,63 bar (150 to 270 lbf/in ²)	24,15 to 26,22 bar (350 to 380 lbf/in ²)	- 5,5 to 2,5 mm (- 0.225 to 0.10 in)
Bentley Turbo R	From *SCBZSOT0XFCH12834*	10,35 to 18,63 bar (150 to 270 lbf/in ²)	24,15 to 26,22 bar (350 to 380 lbf/in ²)	- 5,5 to 2,5 mm (- 0.225 to 0.10 in)
Corniche	From *SCAZD0006CCH05037* to *SCAZD0004ECH07940* excluding *SCAZD0005ECH07815*	10,35 to 16,0 bar (150 to 232 lbf/in ²)	20,7 to 24,15 bar (300 to 350 lbf/in ²)	<i>Other than N. America</i> 4,5 to 12,5 mm (0.175 to 0.5 in) <i>North America</i> 19,5 to 28,0 mm (0.775 to 1.10 in)
Corniche	From *SCAZD42A5ECX07942* onwards including *SCAZD0005ECH07815*	10,35 to 18,63 bar (150 to 270 lbf/in ²)	24,15 to 26,22 bar (350 to 380 lbf/in ²)	<i>Other than N. America</i> - 5,5 to 2,5 mm (- 0.225 to + 0.10 in) <i>North America</i> 9,5 to 17,5 mm (0.375 to 0.70 in)

Gas springs and Suspension struts

Introduction

A rear suspension strut is situated beneath each rear wheel arch. They are mounted between the rear suspension trailing arm and the car body. A gas spring is bolted to the top of each strut.

With the exception of Corniche/Continental cars the gas springs and top mountings of the suspension struts are situated in the luggage compartment.

On Corniche/Continental cars the gas springs and mountings are situated in the hood stowage well.

The gas spring and suspension strut combine to perform the functions of car height levelling and suspension damper. The suspension strut is similar in design to a conventional damper but is supplied with pressurized oil from its respective hydraulic system accumulator, except for Bentley Turbo R, where both struts are supplied by No. 1 system. The gas spring consists of a sphere similar to that fitted to the hydraulic accumulator, divided into two chambers by a rubber diaphragm.

Nitrogen gas, under pressure, is retained on one side of the diaphragm. Refer to the chart in Section G14 for relevant sphere gas pressures. Hydraulic system mineral oil fills the other half of the sphere and suspension strut.

When the road wheel hits a bump the piston of the suspension strut is forced upwards. This action forces mineral oil into the gas spring sphere compressing the gas behind the diaphragm. Conversely, when the road wheel travels over a hollow the piston is forced down by the expansion of the gas.

Holes machined into the suspension strut piston allow a restricted mineral oil flow from one side of the piston to the other thus acting as a shock damper.

Height control is achieved by increasing or decreasing the amount of mineral oil in the suspension strut and gas spring assembly. If extra load is applied to the car the height control valves will actuate and allow extra mineral oil to flow into the suspension strut. This increase in the volume of mineral oil within the suspension strut, effectively raises the body height of the car to the correct levelled height position. When load is removed from the car, the height control valve is actuated in the opposite direction, allowing the excess mineral oil to exhaust from the suspension strut to the respective reservoir, thus lowering the height of the car body.

Gas spring spheres and suspension struts are both non-serviceable items. Therefore, in the event of failure a new component must be fitted.

No attempt should be made to charge a gas spring sphere. All spheres are charged to the correct pressure prior to despatch from the manufacturer.

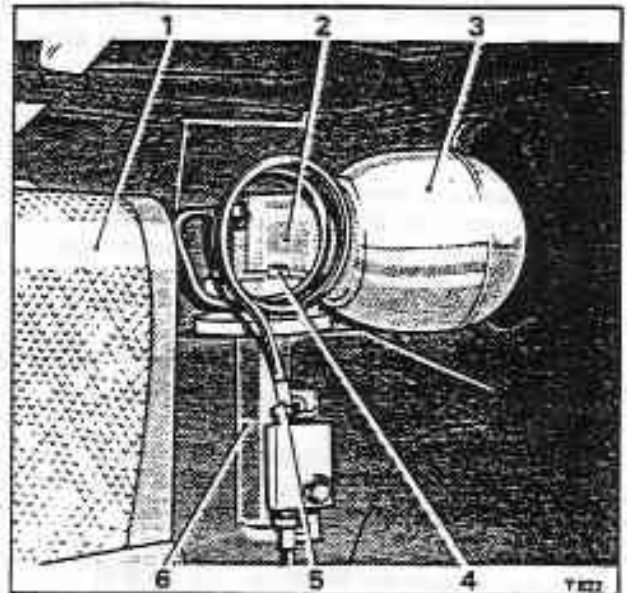

Fig. G15-1 Gas spring sphere (early cars)

- 1 Fuel tank
- 2 Adapter
- 3 Sphere
- 4 Mounting Allen screw
- 5 Pressure supply pipe
- 6 Car body strut tower

Note

RH 9727 GMF pressure gauges are quoted for the testing of the gas spring spheres and suspension struts in this Section. These gauges give a reading of between zero bar and 344 bar (zero lbf/in² and 5000 lbf/in²). However, it is essential that the gauges give a correct reading in the 7 bar to 28 bar (100 lbf/in² to 400 lbf/in²) range.

Gas spring sphere - To remove (see figs. G15-1 and G15-2)

1. Depressurize the hydraulic system as described in Sections G2 and G2/1.
2. Disconnect the battery.
3. Unscrew the Pozidriv screws from the carpet covered sealing panel. Collect the screws and washers.
4. Remove the battery master switch knob and special ring nut from the right-hand side of the panel (if fitted).
5. Release the press stud straps adjacent to each hinge. Withdraw the panel to expose the fuel tank and gas spring spheres.

RROC (A) Editor's Note

Gas Spring Sphere Removal.

The gas spring spheres may best be removed WITHOUT removing the accumulator assembly from the vehicle as prescribed in this manual. This preserves the seal between the accumulator body and the suspension strut, and saves considerable time.

Once the sphere is accessed, simply use a suitable strap wrench such as a sturdy oil filter removal tool, or a chain wrench for very tight spheres. In some cases, in order to use a chain wrench it may be necessary to bend the body seam adjacent to the sphere slightly. This is a very minor procedure and the bend cannot be seen.

Suitable Tools for Gas Spring Sphere Removal



6. Unscrew the setscrews that secure the master switch mounting bracket in position.
7. With care lower the mounting bracket to enable removal of the gas sphere from behind the bracket.
Operations 8 to 11 inclusive are applicable only to Corniche/Continental cars.
8. Carefully remove the rear seat cushion.
9. On cars fitted with rear seat belts, remove the trim covers from the reel mechanisms. Remove the bolts and washers that secure the reels to the parcel shelf. Remove the reels.
10. Release the lower seat squab brackets from the body. Lift and slide the seat squab upwards. Remove the squab.
11. Release and remove the parcel shelf to gain access to the rear suspension strut spheres.
12. Disconnect the coiled feed pipe from the gas spring, blank off the pipe and port.
13. Remove the three Allen screws from the gas spring adapter.
14. Carefully lift the adapter and sphere off the top of the suspension strut and remove it from the car. Discard the sealing rings.
15. Secure the sphere adapter in a soft jawed vice. Using a suitable strap spanner, unscrew the sphere from the adapter. Discard the sealing ring.

Gas spring sphere - To fit (see fig. G15-3)

Fit the sphere by reversing the procedure for removal noting the following.

1. Ensure that all components are free from burrs. Thoroughly clean them with Genklene or methylated

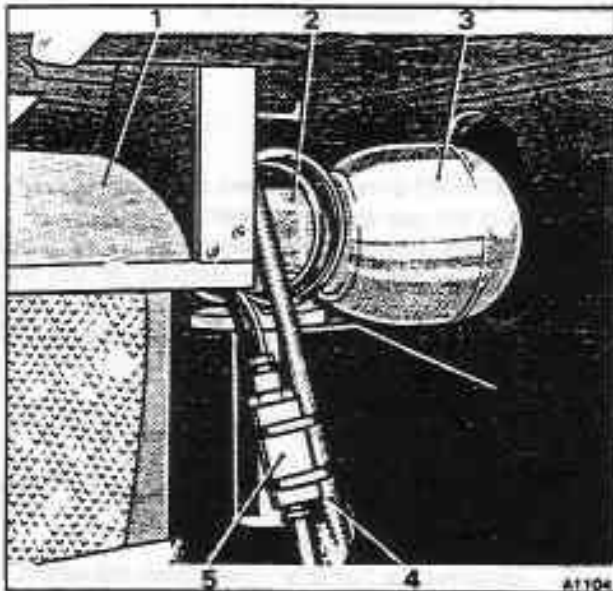

Fig. G15-2 Gas spring sphere (later cars)

- 1 Fuel tank
- 2 Adapter
- 3 Sphere
- 4 Parcel shelf tie-bar
- 5 In-line filter

spirits. Dry with clean compressed air. Do not use any type of cloth.

2. Lubricate the new sealing rings with clean hydraulic system mineral oil.
3. If a replacement sphere is being fitted, remove the blanking cover and allow any hydraulic system mineral oil to drain from the sphere.
4. Torque tighten all setscrews and pipe connections in accordance with the figures quoted in Section G19 and Chapter P.
5. On completion bleed the hydraulic system as described in Sections G4 and G4/1. Check all disturbed joints and pipe connections for leaks.
6. Applicable to Corniche/Continental cars only. Carefully replace the parcel shelf, rear seat squab, rear seat belt reels, and seat cushion.

Suspension strut - To remove (see figs. G15-3 and G15-4)

1. Place the car on a ramp and securely chock the front wheels.
2. Depressurize the hydraulic system as described in Sections G2 and G2/1.
3. Raise the rear of the car and place sill blocks under the rear end of the body sills. Support the trailing arms in the raised position; do not allow the suspension rebound struts to support the full suspension load.
4. Remove the relevant rear wheel trim and the rear wheel.
5. Remove the gas spring sphere as described under Gas spring sphere - To remove. Fit a protective blank to the top of the strut.
6. Disconnect the leakage return pipe from the lower end of the suspension strut. Blank off the port and pipe connections.
7. Remove the self-locking nut from the lower end of the suspension strut situated at the rear of the suspension trailing arm. Collect the rubber mounting bush and cup-washer.

Note

In order to prevent rotation of the strut during removal of the retaining nut the location pin should be inserted through the mount. For details refer to Suspension strut - To fit.

8. Remove the retaining nut from the upper suspension strut mount. Collect the rubber mounting bush, gas spring mount, and cup-washers.
9. Support the suspension strut and lower the trailing arm. Lower the suspension strut from beneath the car, taking care not to damage the gas spring connection stem. Collect the rubber mounts, distance pieces, and cup-washers.

Suspension strut - To fit (see fig. G15-5)

In order to correctly locate the suspension strut into position, location holes are situated in the top face of the suspension strut and mount components. These location holes can be aligned by using a 76.20 mm (3 in) length of 4.75 mm (0.187 in) diameter bar.

The location peg can be fitted to either of two diametrically opposed holes in the strut, dependent on

which side of the car the suspension strut is to be fitted. When positioned correctly the seepage drain unions should point rearwards on both sides of the car. Fit the suspension strut by reversing the procedure for removal noting the following.

1. Fully compress the suspension strut. Retain the piston rod in this position with a suitable piece of wire or rubber band attached to the drain union.
2. Fit the upper strut mount, distance piece, cup-washers, and locating peg into position on the strut stem.
3. Pass the strut stem through the hole in the body strut tower using the peg to locate its angular position i.e. drain union to the rear of the car.
4. Fit the cup-washer, rubber mount, and gas spring mount onto the strut stem and location pin. Fit and torque tighten the stem nut to the figures quoted in Section G19.
5. Remove the location pin.
6. Connect the strut piston rod to the trailing arm using a self-locking nut. Torque tighten the nut to the figures quoted in Section G19.
7. Remove the protective cap from the strut stem. Lubricate the two stem sealing rings with hydraulic system mineral oil prior to fitting to the strut stem.
8. Fit the gas spring sphere assembly onto the strut stem mount, taking care not to damage the sealing rings (see Gas spring sphere - To fit).
9. All nuts, capscrews, and pipe connections should be torque tightened in accordance with the figures quoted in Section G19 and Chapter P.
10. On completion, bleed the hydraulic system as described in Sections G4 and G4/1.

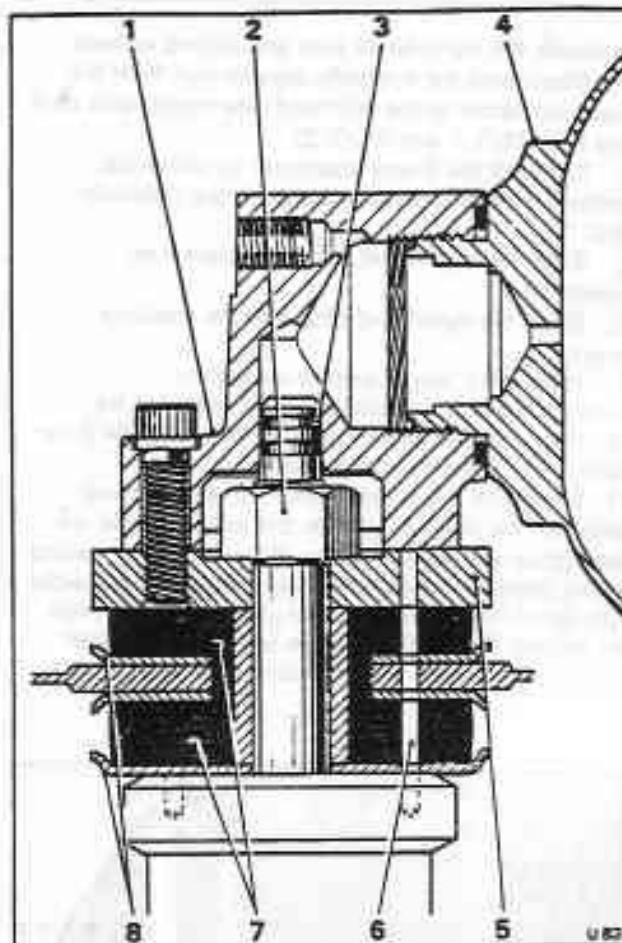

Fig. G15-3 Gas spring to suspension strut mounting

- 1 Adapter
- 2 Strut retaining nut
- 3 Sealing rings
- 4 Gas spring sphere
- 5 Gas spring mounting plate
- 6 Location peg holes
- 7 Rubber mounts
- 8 Cup-washer

Gas spring sphere and Suspension strut operating pressures - To check

Cars other than Bentley Turbo R

If a malfunction of the levelling system or ride deterioration is difficult to diagnose the gas spring gas charge pressure and the suspension strut operating pressure should be checked as follows.

1. Place the car on a ramp and securely chock the front wheels.
2. Depressurize the hydraulic system as described in Section G2.
3. Fit the pressure gauge RH 9727 GMF into the suspension strut bleed screw.
4. Disconnect the height control rods at the lower end.
5. Start the engine and allow the systems to pressurize.
6. Raise the two height control valve links approximately 25,4 mm (1.0 in) and allow the car to level.
7. Keep the links raised until a pressure of 34,5 bar (500 lbf/in²) is indicated in the struts.
8. Switch off the engine. Open the bleed screw on the pressure gauge; the gauge needle will commence to descend slowly. Note the actual reading on the pressure gauge when the needle drops sharply. This figure indicates the actual gas pressure within the sphere. The figure must be within the required limits, refer to the chart in Section G14.

9. Connect the height control rods at the lower end.
10. Remove the pressure gauge.
11. Fit the suspension strut bleed screw(s).
12. Top-up the reservoir(s), refer to Section G5.

Gas spring sphere and Suspension strut operating pressures - To check

Bentley Turbo R

1. Place the car on a ramp and securely chock the front wheels.
2. Depressurize the hydraulic system as described in Section G2/1.
3. Fit the pressure gauge RH 9727 GMF into the suspension strut bleed screw port.
4. Disconnect the height control valve links at the lower end.

G15-4

- To check the right-hand side gas spring sphere
5. Disconnect the hydraulic pipe section from the 3-way connector to the left-hand side suspension strut (see figs. G1/1-1 and G1/1-2).
 6. Blank off the 3-way connector to withstand hydraulic system pressure. Blank off the hydraulic pipe.
 7. Start the engine and allow the system to pressurize.
 8. Bleed the right-hand strut and the pressure gauge.
 9. Raise both height control valve links simultaneously, approximately 25,4 mm (1.0 in).
 10. Keep the links raised until a pressure of 34,5 bar (500 lbf/in²) is indicated in the strut.
 11. Switch off the engine. Slowly open the bleed screw on the pressure gauge; the gauge needle will commence to descend slowly. Note the actual reading on the pressure gauge when the needle drops sharply. This figure indicates the actual gas pressure within the sphere. The figure must be within the required limits, refer to the chart in Section G14.

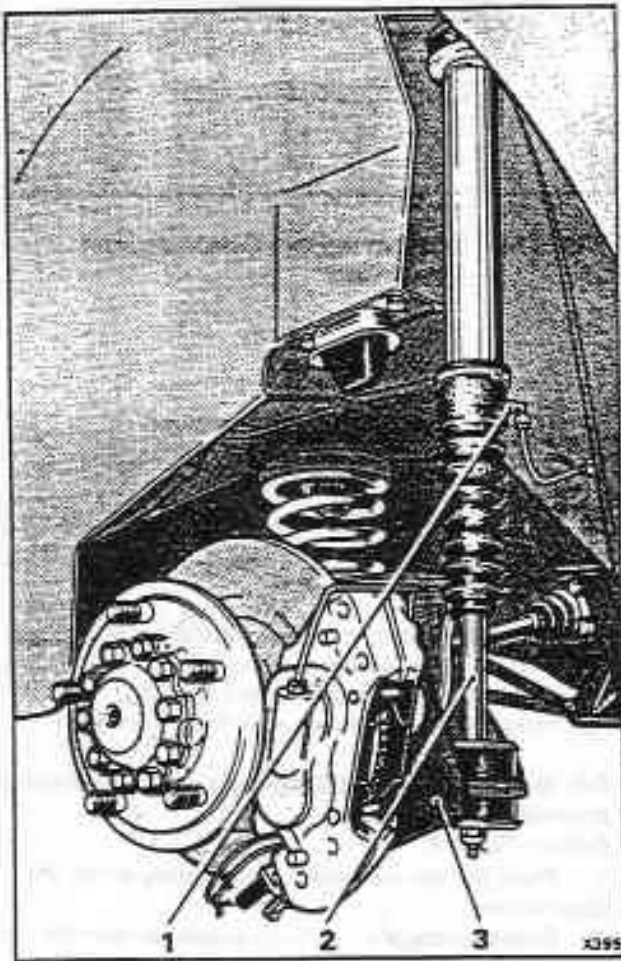

Fig. G15-4 Rear suspension strut

- 1 Leakage return pipe
- 2 Suspension strut
- 3 Trailing arm

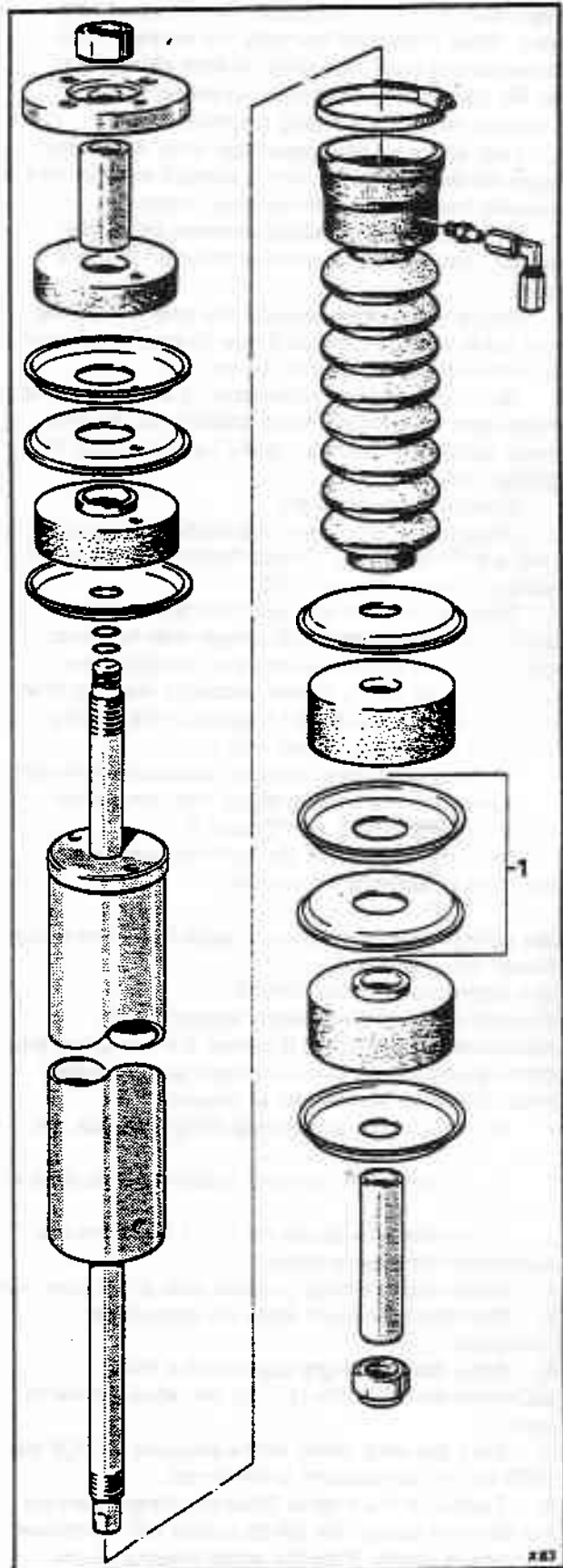

Fig. G15-5 Rear suspension strut mounts

- 1 Cup-washers (welded to the trailing arm on later cars)

12. Depressurize the system as described in Section G2/1.

13. Remove the blanks from both the 3-way connector and the hydraulic pipe. Connect the hydraulic pipe to the connector. Ensure that the restrictor is fitted. Torque tighten in accordance with the figures quoted in Section G19.

To check the left-hand side gas spring sphere.

14. Disconnect the hydraulic pipe section from the 3-way connector to the right-hand side suspension strut (see figs. G1/1-1 and G1/1-2).

15. Blank off the 3-way connector to withstand hydraulic system pressure. Blank off the hydraulic pipe.

16. Start the engine and allow the system to pressurize.

17. Bleed the left-hand strut and the pressure gauge.

18. Raise both height control valve links simultaneously, approximately 25,4 mm (1.0 in).

19. Keep the links raised until a pressure of 34,5 bar (500 lbf/in²) is indicated in the strut.

20. Switch off the engine. Slowly open the bleed screw on the pressure gauge; the gauge needle will commence to descend slowly. Note the actual reading on the pressure gauge when the needle drops sharply. This figure indicates the actual gas pressure within the sphere. The figure must be within the required limits, refer to the chart in Section G14.

21. Depressurize the system as described in Section G2/1.

22. Remove the blanks from both the 3-way connector and the hydraulic pipe. Connect the hydraulic pipe to the connector. Torque tighten in accordance with the figures quoted in Section G19.

23. Remove the pressure gauge.

24. Fit the suspension strut bleed screw.

25. Connect the height control valve links.

26. Bleed the system in accordance with Section G4/1.

27. Top-up the reservoirs in accordance with Section G5/1.

Front and rear disc brakes

Introduction

Two twin cylinder calipers are fitted to each front wheel and a four cylinder caliper to each rear wheel.

The calipers are divided between the two independently operated hydraulic systems, System 1 operates the front calipers on the front wheels and the upper cylinders on the rear wheel calipers. System 2 operates the rear calipers on the front wheels and the lower cylinders on the rear wheel calipers.

Bleed screws are fitted to the inner face of each caliper to facilitate bleeding of the two systems.

Brake calipers fitted to cars with mineral oil hydraulic systems are similar in appearance to those fitted to cars using conventional brake fluid (i.e. RR363). In order to distinguish calipers suitable for use with hydraulic system mineral oil a section of the outer surface is painted green. The calipers are also fitted with a green identification tag around each bleed screw.

Under no circumstances should a caliper for use with a conventional brake fluid be used as a replacement.

In order to obtain a maximum efficiency and safety from the braking systems it is important that only replacement disc pads of an approved design and material specification are fitted.

Brake pads of a different specification or different manufacture vary in their friction, wear, and operating characteristics and if mixed could have an adverse effect on the braking performance.

It is important when changing the brake pads that the friction material of the new pads is of the same type and grade as that fitted to the other brake calipers, otherwise it will be necessary to renew all the brake pads.

Inspection of all brake pads must be carried out at the specified service intervals; for details reference should be made to the Service Schedule Manual publication number TSD 4406.

The brake pads must be renewed when the brake pad linings are worn to within 3.18 mm (0.125 in) of the back plate.

After fitting new brake pads an initial running-in period of between 1100 kilometres and 1300 kilometres (700 miles and 800 miles) should be observed.

During this initial running-in period, the brakes should not be applied harshly or for prolonged periods from high speeds except in an emergency. The force with which the brakes are applied may be progressively increased towards the end of the running-in period.

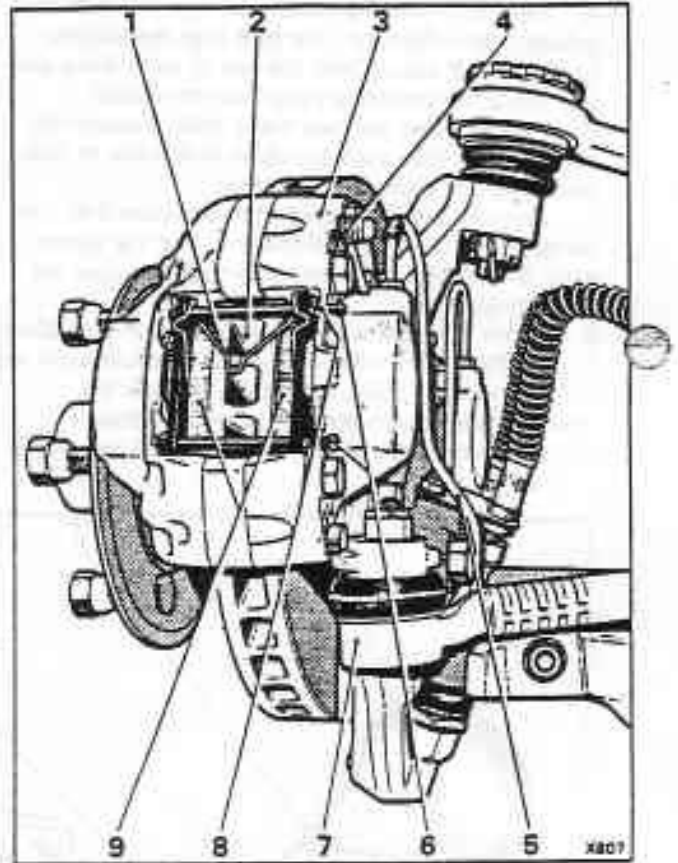

Fig. G16-1 Front wheel front brake caliper

- 1 'M' spring
- 2 Brake disc
- 3 Brake caliper
- 4 Bleed screw
- 5 Brake pressure supply pipe
- 6 Brake pad retaining pins
- 7 Track rod
- 8 Pin retaining clips
- 9 Brake pads

Note

If the brakes are to be relined with pads which have different recommended linings from those previously fitted, the disc faces should be cleaned prior to fitting the new pads. All traces of the old pad material should be removed by hand rotating the disc whilst applying fine emery cloth to the disc faces. Do not emery the disc radially. Always ensure that the same type and grade of pad lining is fitted to all six brake calipers.

Front wheel brake pads - To renew (see figs.G16-1 and G16-2)

1. Slacken but do not remove the front road wheel retaining nuts.
2. Securely chock the rear road wheels. Jack up the front of the car. Support the car with stands and sill blocks.
3. Remove the front road wheels.
4. Remove the spring clips from the two brake pad retaining pins. Withdraw the pins from the caliper. Unclip the 'M' spring from the rear of each brake pad.
5. Withdraw the brake pads from the caliper.
6. Prior to fitting the new brake pads; inspect the caliper piston dust seals for signs of damage or heat hardening and renew as necessary.
7. Carefully press the caliper pistons back into their bores, taking care not to damage or trap the piston seals. Ensure that the piston seal retaining clips are correctly located.
8. Fit the new brake pads into position in the caliper.
9. Fit the trailing brake pad retaining pin through the caliper and brake pads. Secure the pin with the retaining clip. Ensure that the pads slide freely.
10. Locate the ends of the 'M' spring into the centre

holes of the brake pad back plate. Ease the spring into position and secure with the leading pad retaining pin. Fit the pin retaining clip. When fitted the 'ears' of the 'M' spring must rest on the edge of the brake pad backing plate, with the bends at the top of the 'M' figuration butting against the caliper body (see fig. G16-1).

Note

The 'M' spring is only fitted onto the brake pad retaining pin at the leading end of the caliper, i.e. upper pin on the front brake caliper and lower pin on the rear brake caliper.

When fitting the 'M' spring do not compress the spring, more than the normal gap between the two brake pads, otherwise permanent distortion of the spring may occur.

Due to inherent distortion during pad wear, new 'M' springs should be fitted whenever the brake pads are renewed.

Rear wheel brake pads - To renew (see figs.G16-3 and G16-4)

1. Securely chock the front road wheels. Jack up the

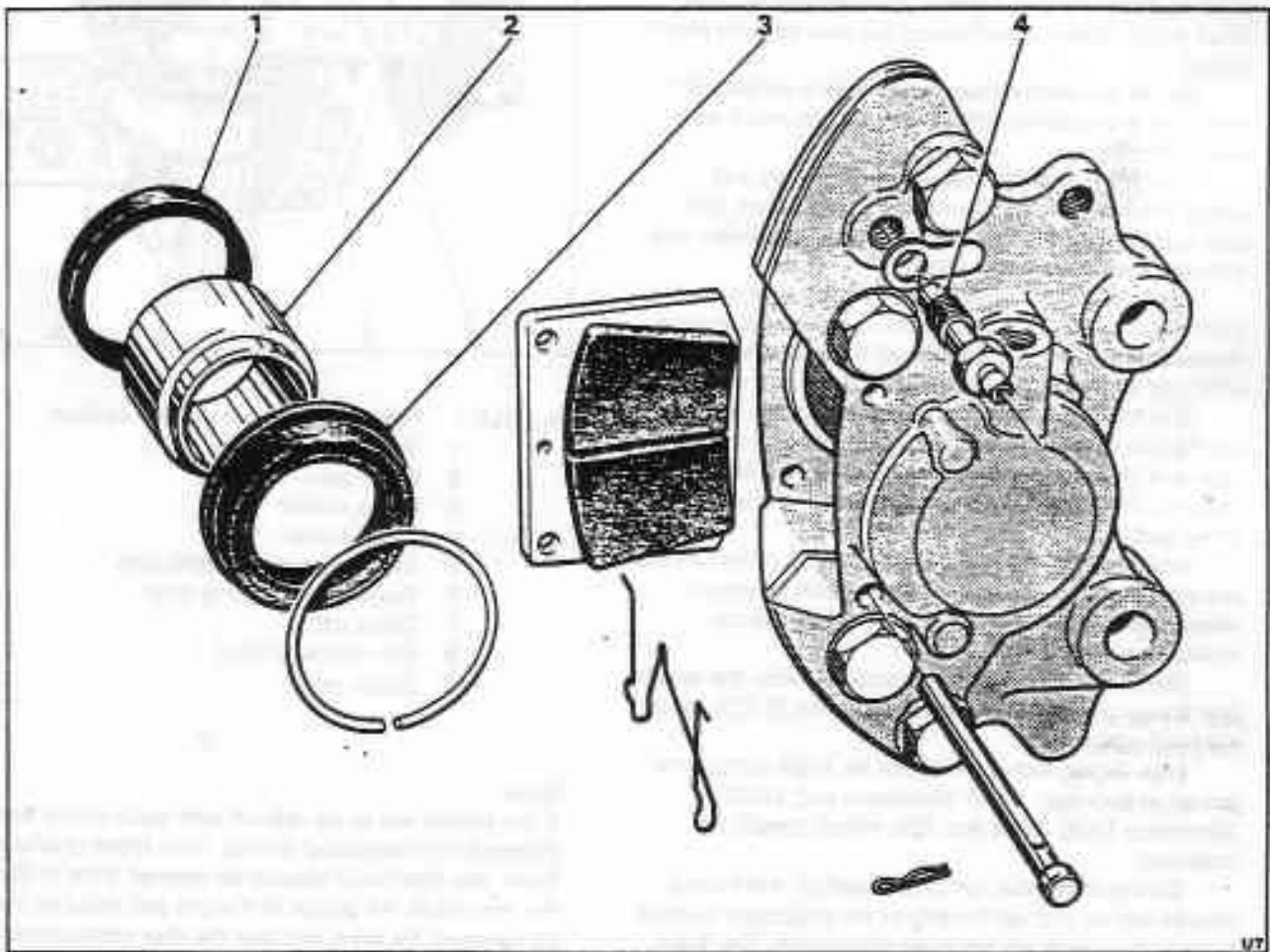

Fig. G16-2 Front wheel brake caliper (left-hand rear shown)

- | | | | |
|---|-------------|---|-------------|
| 1 | Piston seal | 3 | Dust seal |
| 2 | Piston | 4 | Bleed screw |

holes of the brake pad back plate. Ease the spring into position and secure with the leading pad retaining pin. Fit the pin retaining clip. When fitted the 'M' spring must rest on the edge of the brake pad backing plate, with the bends at the top of the 'M' figuration butting against the caliper body (see fig. G16-1).

Note

The 'M' spring is only fitted onto the brake pad retaining pin at the leading end of the caliper, i.e. upper pin on the front brake caliper and lower pin on the rear brake caliper.

When fitting the 'M' spring do not compress the spring, more than the normal gap between the two brake pads, otherwise permanent distortion of the spring may occur.

Due to inherent distortion during pad wear, new 'M' springs should be fitted whenever the brake pads are renewed.

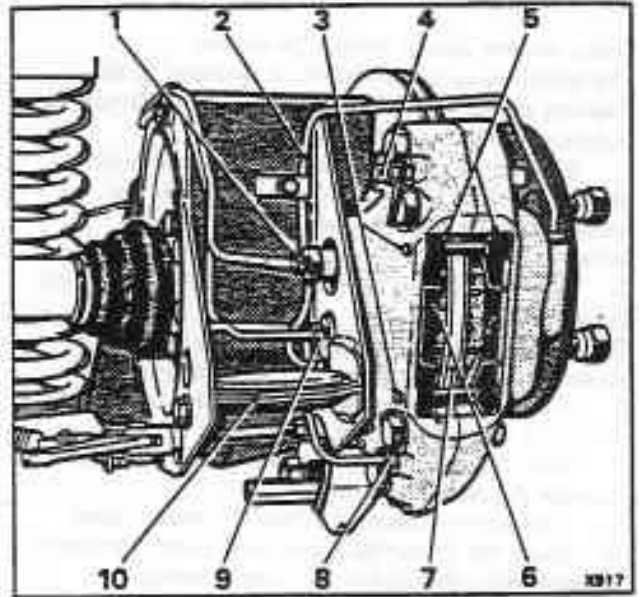

Fig. G16-3 Rear wheel brake caliper

- 1 Upper cylinder supply pipe
- 2 Lower cylinder supply pipe
- 3 Brake pad retaining pins
- 4 Upper cylinder bleed screw (No. 1 system)
- 5 Anti-rattle spring clips
- 6 Brake pads
- 7 Brake disc
- 8 Lower cylinder supply pipe
- 9 Lower cylinder bleed (No. 2 system)
- 10 Trailing arm suspension strut mount

Rear wheel brake pads - To renew (see figs. G16-3 and G16-4)

1. Securely chock the front road wheels. Jack up the rear of the car. Support the car with stands and sill blocks.
2. Remove the rear road wheels.
3. Remove the spring clips from the two brake pad retaining pins (see fig. G16-3). Withdraw the pins. Collect the anti-rattle spring clips from the rear of each brake pad.
4. Withdraw the brake pads from the caliper.
5. Prior to fitting the new pads, inspect the caliper piston dust seals for signs of damage or heat hardening. Renew as necessary.
6. Carefully press the caliper pistons back into their bores, taking care not to damage or trap the seals. Ensure that the seal retaining clips are correctly located.
7. Fit the new pads by reversing the removal procedure, ensure that the pads slide freely. Ensure that the anti-rattle spring clips and pad retaining pin clips are correctly located (see fig. G16-3), heads of the retaining pins to be on the wheel side of the caliper.

8. It is recommended that a distance piece is fitted between the caliper pads after removal, to prevent the pistons easing out of their bores.

Front brake caliper - To remove (see figs. G16-1 and G16-2)

1. Depressurize the hydraulic systems as described in Section G2.
2. Securely chock the rear road wheels.
3. Remove the wheel disc from the front wheel then slacken but do not remove the wheel retaining nuts.
4. Raise the front of the car on a hydraulic jack. Securely support the car on stands and sill blocks.
5. Remove the road wheels.
6. Disconnect the caliper feed pipe, blank off the pipe end and caliper port against the ingress of dirt.
7. Remove the fitted bolts which secure the caliper to the axle yoke. Withdraw the caliper from off the brake disc.

Rear brake caliper - To remove (see figs. G16-3 and G16-4)

1. Depressurize the hydraulic systems as described in Section G2.
2. Securely chock the front wheels of the car.
3. Remove the wheel disc then slacken but do not remove the wheel retaining nuts.
4. Raise the rear of the car with a hydraulic jack.
5. Remove the road wheels.
6. Disconnect the parking brake operating rod from the caliper lever.
7. Disconnect the two feed pipes from the caliper; fit blanks to the pipe ends and caliper ports.
8. Remove the caliper bridge pipe; fit blanks to the pipe ends and caliper ports.
9. Remove the pipe connection adapter and lower bleed screws from the inner face of the caliper.
10. Remove the fitted bolts securing the caliper to the rear hub yoke.
11. Carefully withdraw the caliper off the brake disc.
12. Slacken the four bolts securing the hub yoke to the trailing arm approximately four revolutions. Carefully draw the hub assembly away from the trailing arm until sufficient clearance is obtained to allow the removal of the caliper from the brake discs.

Brake caliper piston seals - To renew
 The brake caliper seals should be renewed at the intervals specified in the Service Schedule Manual publication number TSD 4406.

Only seals suitable for use with hydraulic system mineral oil must be fitted. Under no circumstances should seals for use with conventional brake fluid (i.e. RR363) be used.

1. Depressurize the hydraulic systems as described in Section G2.
2. Remove the brake caliper from the car and remove the brake pads as described previously.
3. Remove the spring clip retaining the caliper piston dust seal; remove the dust seal.
4. Ease the piston from its bore taking care not to damage the piston.
5. Remove the piston seal from the caliper bore.
6. Clean the caliper bore and piston with Genklene or methylated spirits. Dry thoroughly, using dry compressed air, not any type of cloth.
7. Immerse the new piston seal in an approved

hydraulic system mineral oil (refer to Chapter D). Then, carefully insert it into the groove in the caliper bore, ensuring that it is correctly seated.

8. Lubricate the piston outside diameter with a small quantity of an approved hydraulic system mineral oil, carefully fit the piston.

9. Fit a new dust seal around the piston top and over the caliper bore flange. Fit the spring ring taking care not to 'pinch' the seal with the ends of the ring.

Brake calipers - To fit

Fit the brake calipers by reversing the respective removal procedure noting the following.

1. All setscrews and pipe connections must be torque tightened in accordance with the figures quoted in Section G19 and Chapter P.
2. Ensure that a minimum clearance of 8.0 mm (0.312 in) is maintained between the caliper bridge pipe and the brake disc when fitting rear brake calipers.

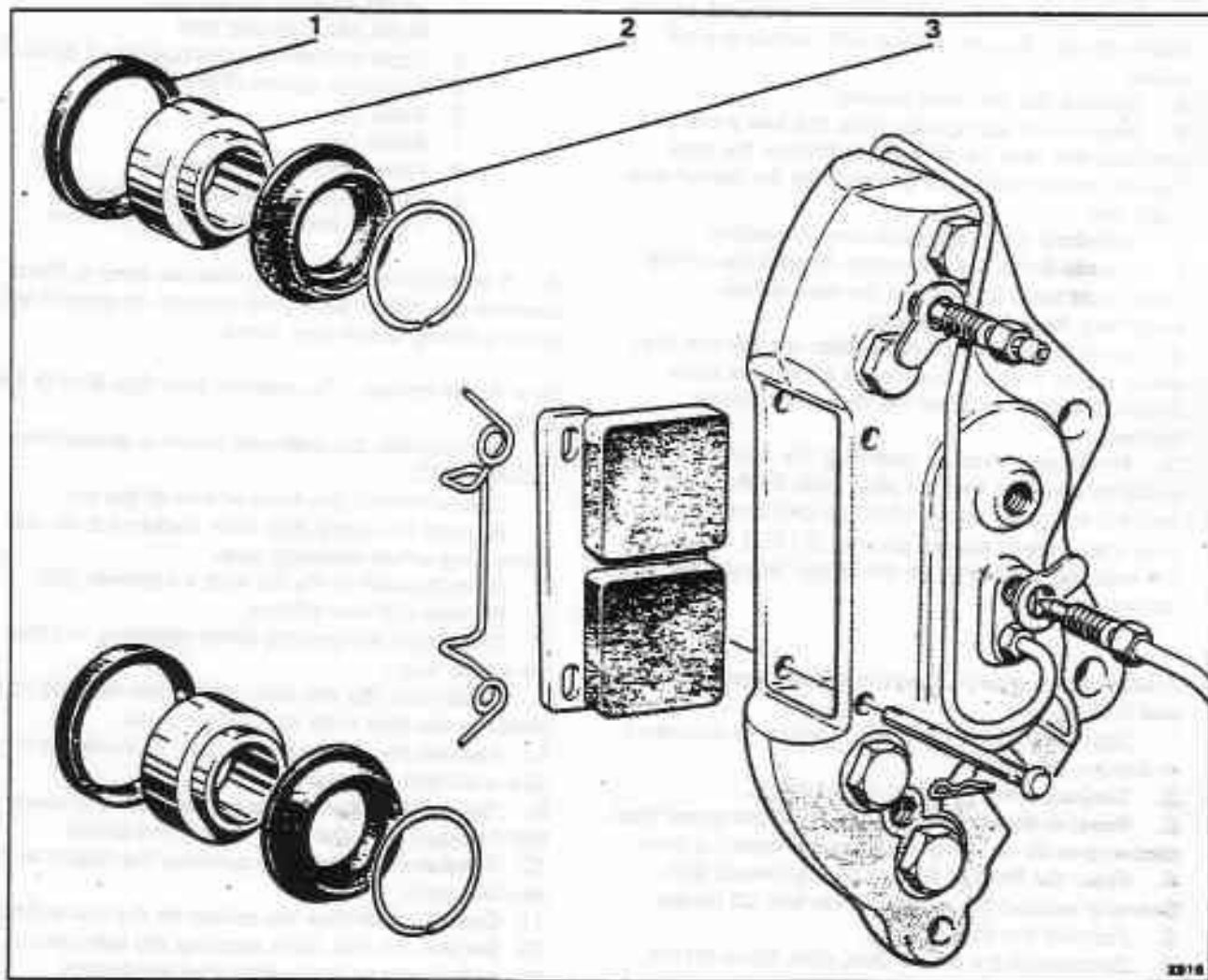

Fig. G16-4 Rear wheel brake caliper

- | | |
|---|---|
| <ol style="list-style-type: none"> 1 Piston seal 2 Piston | <ol style="list-style-type: none"> 3 Dust seal |
|---|---|

3. When fitting is completed, bleed the hydraulic systems as described in Section G4.

Note

The supply pipe connection ports on the front wheel brake calipers are a metric threaded fitting and only pipes fitted with the correct metric pipe nuts should be used.

Brake disc - To remove

1. Depressurize the hydraulic systems as described in Section G2.
2. Remove the front or rear hub as necessary, following the procedure described in Chapter H Front hubs or Chapter J Rear hubs.
3. To remove a front disc remove the setscrews securing the disc to the hub.
4. To remove a rear brake disc dismantle the rear hub as described in Chapter J then unscrew the disc retaining setscrews.

Brake disc - To fit

Fit the brake disc by reversing the procedure for removal noting the following.

1. All setscrews must be torque tightened in accordance with the figures quoted in Section G19.
2. The hubs must be assembled and fitted as described in their respective Chapters H or J.
3. On completion the hydraulic systems must be bled as described in Section G4.

Note

New brake discs are treated with a protective film. When a new disc has been fitted the brakes should be gently applied until the protective film has been removed from the working surface of the disc by the first few brake applications.

If only one front brake disc has been replaced the car will gently pull to the side opposite the new disc until the protective film has been removed.

Parking brake linkage

Introduction

The parking brake is operated by a foot pedal application with a hand pull release for both right-hand and left-hand drive cars.

The mechanism operates a caliper lever arrangement fitted beneath the two rear hydraulic brake calipers. These levers apply a wedge shaped friction pad to each side of the brake disc.

The parking brake should be inspected for wear and manually adjusted at the intervals specified in the Service Schedule Manual TSD 4406.

Pads must be renewed when the friction material has worn to within 3.18 mm (0.125 in) of the pad back plates.

Foot operated parking brake mechanism - To remove

1. Place the car on a ramp. Securely chock the road wheels. Release the parking brake.
2. At the intermediate linkage on the underside of the body, unhook the parking brake return spring from the operating lever. Remove the clevis pin attaching the front brake cable to the lever (see fig. G17-1).
3. Remove the knee roll trim from the parking brake area as described in Chapter S in order to gain access to the two setscrews and the two studs, which retain the foot pedal mechanism in position.
4. Disconnect the Lucar connectors from the micro-switch.
5. Disconnect the brake cable from the cable connector attached to the pedal lever.
6. Remove the two setscrews and two nuts that retain the mechanism in position. Lower the mechanism from beneath the fascia.

Foot operated parking brake mechanism - To dismantle (see fig. G17-2)

1. Remove the foot operated parking brake mechanism as described previously.
2. Remove the side plates guard from the mechanism assembly, taking care not to damage the clipping tabs.
3. Remove the micro-switch, collect the screws, nuts, and washers.
4. Remove the cable connector from the pedal lever by removing a circlip from one end of the pin. Withdraw the pin. Collect the pin, circlip, and connector.
5. Remove the sprag plate stop by removing the setscrew and the self-tapping screw.
6. Straighten the tension spring split pin. Withdraw the pin from the sprag plate to release the spring.
7. Remove the sprag plate by removing the circlips and washers from the pivot pin. Withdraw the pivot

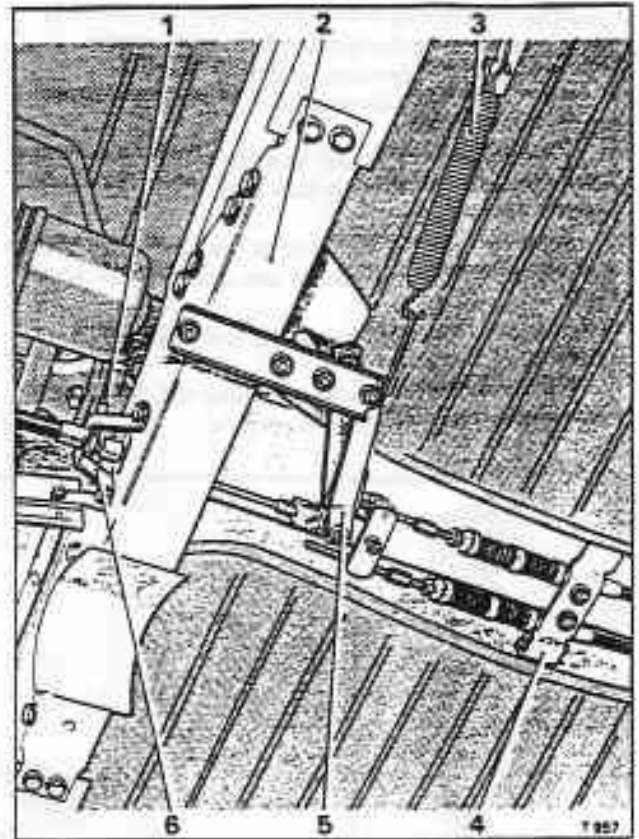

Fig. G17-1 Parking brake intermediate linkage

- 1 Propeller shaft
- 2 Centre body member
- 3 Return spring
- 4 Abutment bracket - rear brake cables
- 5 Operating lever
- 6 Mounting bracket - front brake cable

pin from the mechanism to release the sprag plate. Withdraw the sprag plate from off the sprag rod.

8. Disconnect the sprag rod from the pedal lever by removing one of the retaining circlips from the pivot pin. Withdraw the pivot pin from the sprag rod and pedal lever.

Note

The following operation is only necessary if damage to the pedal lever is evident.

9. Carefully drill out the pedal lever pivot pin to release the pedal lever from the two side plates. Withdraw the pedal lever from the assembly.

Note

If the release handle and rod are not damaged and operate correctly the following operations are not necessary.

10. Remove the Starlock fixing clip and spire linkage clip from the longest release handle slide rod.
11. Remove the split pin, washer, and spring from the shortest release handle slide rod. Carefully remove the release handle from the parking brake mechanism.

Foot operated parking brake mechanism - To assemble (see fig. G17-2)

Assemble the parking brake mechanism by reversing the procedure given for dismantling, applying the following recommendations whilst noting that Operation 1 will only be necessary if the pedal lever needs to be replaced.

1. Position the pedal lever locating it with a new pin. Secure in place by rivetting over each end of the pin to grip the side plates.
2. Sparingly smear the inside of the sprag plate pivot hole with Retinax 'A' grease or any suitable equivalent.

Note

The sprag rod must be clean, dry, and free from lubricant.

3. Fit the sprag plate onto the sprag rod, securing in place with a retaining pin and circlips.

4. Ensure that the cable connector cut-out is on the right-hand side when viewed from the front.
5. Adjust the mechanism as described under Foot operated parking brake mechanism - To adjust.

Foot operated parking brake mechanism - To adjust
The following operations can be carried out with the unit removed from the car.

1. Slowly depress the pedal from the 'off' position through its travel. The sprag plate will move forwards from its 'off' position for the first part of its travel and then move backwards towards the stop plate.
2. The sprag plate stop must be set with a clearance of 0,6 mm (0.025 in) between itself and the sprag plate when the pedal is in the full 'on' position. Torque tighten the locking setscrew on the stop in accordance with the figures quoted in Chapter P. Also tighten the self-tapping screw.
3. With the pedal mechanism in the 'off' position adjust the micro-switch so that it is depressed, tighten the setscrews.
4. To check that the micro-switch is functioning correctly move the pedal away from the 'off' position.

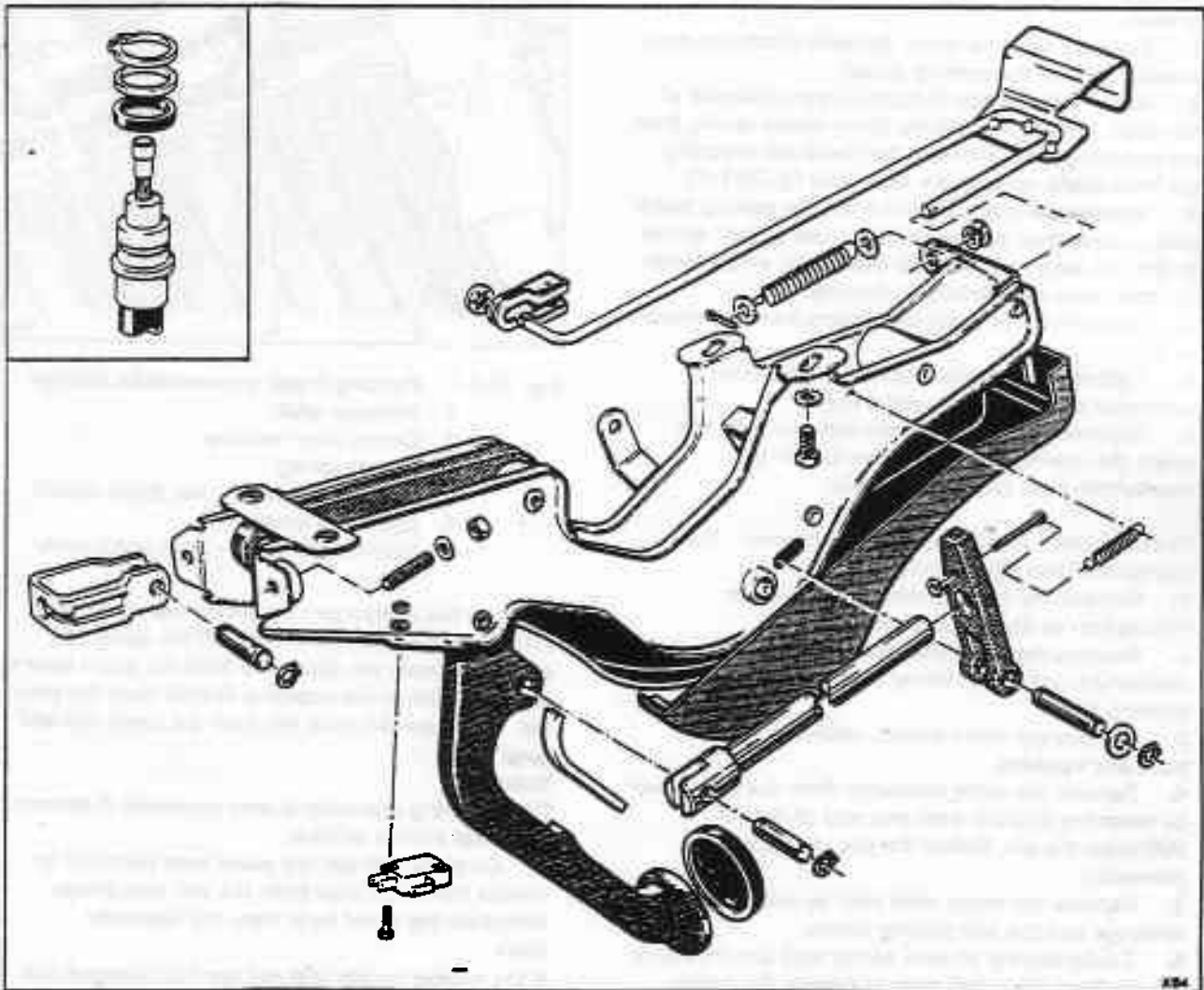

Fig. G17-2 Foot operated parking brake and cable connection

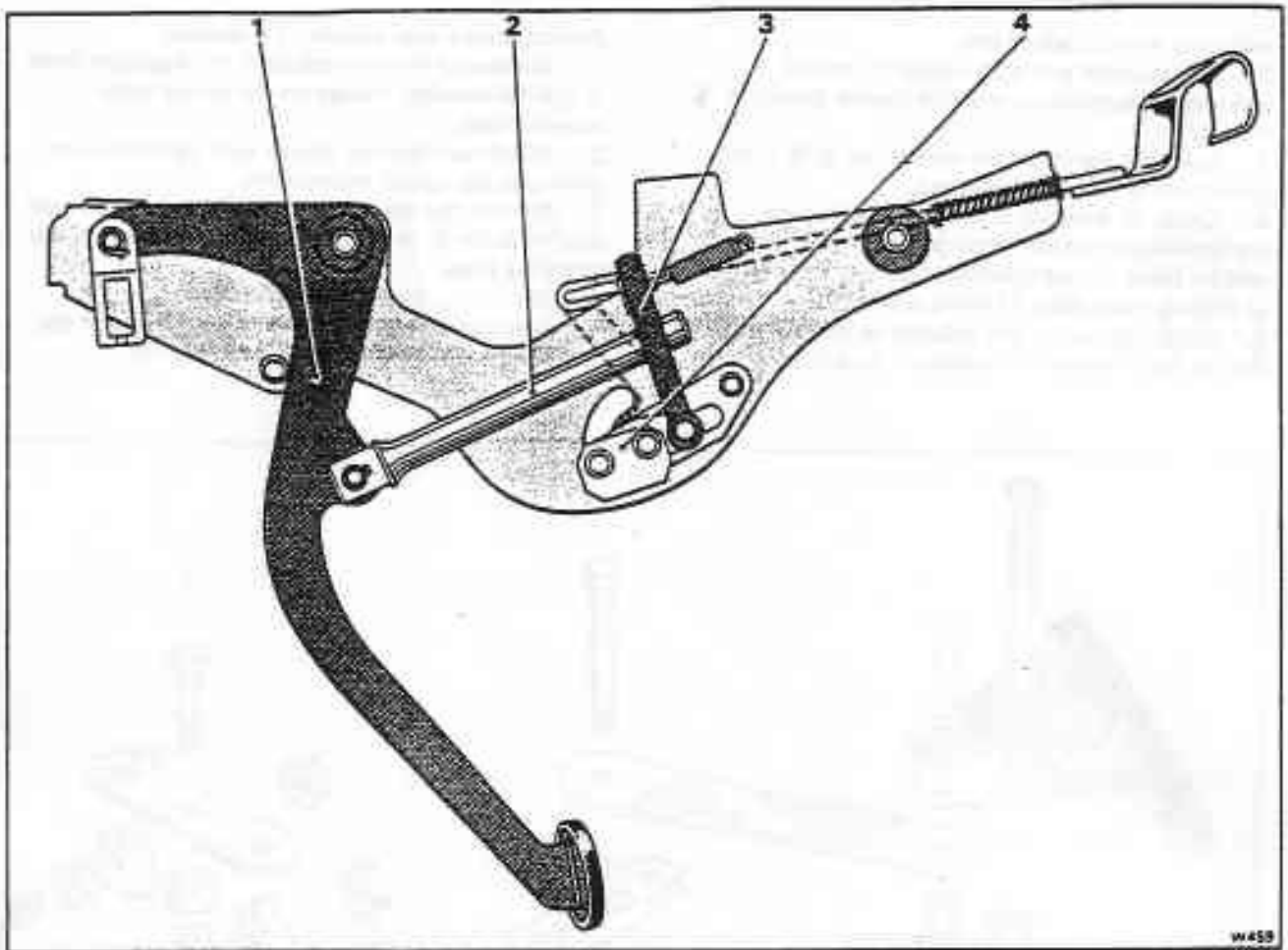

Fig. G17-3 Foot operated parking brake adjustment components

- | | |
|--------------|---------------------|
| 1 Foot pedal | 3 Sprag plate |
| 2 Sprag rod | 4 Release mechanism |

The switch should 'click' on and then 'off' with the reverse movement, adjust as necessary.

Foot operated parking mechanism - To fit
Fit the foot operated parking brake unit by reversing the removal procedure noting the following.

1. All setscrews and nuts should be torque tightened to the figures quoted in Chapter P.
2. Care should be taken to ensure that the brake cable end is located correctly in the connector link of the unit.

Foot operated parking brake mechanism - To check

1. Check the movement of the release handle, as it should not foul the trim at any point during its full travel. If it does foul do not bend the slide rods, reposition the complete unit.

If the slide rods are bent, the handle slide rod assembly must be removed and a new one fitted. Refer to, Foot operated parking brake mechanism - To dismantle.

2. With the parking brake pads 'bedded in', cables and linkages adjusted, depress the pedal fully and pull the release handle gently. If the pedal does not release check the sprag plate stop setting. Refer to, Foot

operated parking brake mechanism - To adjust.

Parking brake front cable - To remove

1. Carry out Operations 1 and 2 of Foot operated parking brake mechanism - To remove.
2. Disconnect the front end of the brake cable from the cable connector which is attached to the pedal lever.
3. Remove the circlip retaining the outer cable to the body floor below the foot pedal mechanism.
4. Disconnect the rear end of the outer cable from the support bracket on the centre crossmember of the body.
5. Disconnect the clip securing the cable to the bracket on the transmission sump.
On left-hand drive cars disconnect the clip securing the cable to the throttle cross-shaft bracket.
6. Remove the cable from the car.

Parking brake front cable - To fit

Fit the parking brake front cable by reversing the procedure given for removal noting the following.

1. On right-hand drive cars ensure that the cable passes between the transmission casing and throttle lever. On left-hand drive cars the cable must pass

under the exhaust heatshield.

2. All setscrews and nuts should be torque tightened in accordance with the figures quoted in Chapter P.
3. Lubricate the clevis pin with Rocol MTS 1000 grease or any suitable equivalent.
4. Check for freedom of operation during the application and release of the parking brake. The parking brake should operate freely without roughness or binding throughout its entire operation.
5. Adjust the cables and calipers as described under Parking brake cables and calipers - To adjust.

Parking brake rear cables - To remove

1. Disconnect the rear cables at the equalizer fitted to the intermediate linkage on the centre body crossmember.
2. Disconnect the rear end of each cable from the parking brake caliper mechanism.
3. Remove the two centre bolts from the abutment bracket at the front end of the cables; collect the top clamping plate.
4. Disconnect the cable support clips.
5. Carefully withdraw the cables from beneath the heat shields and remove them from the car.

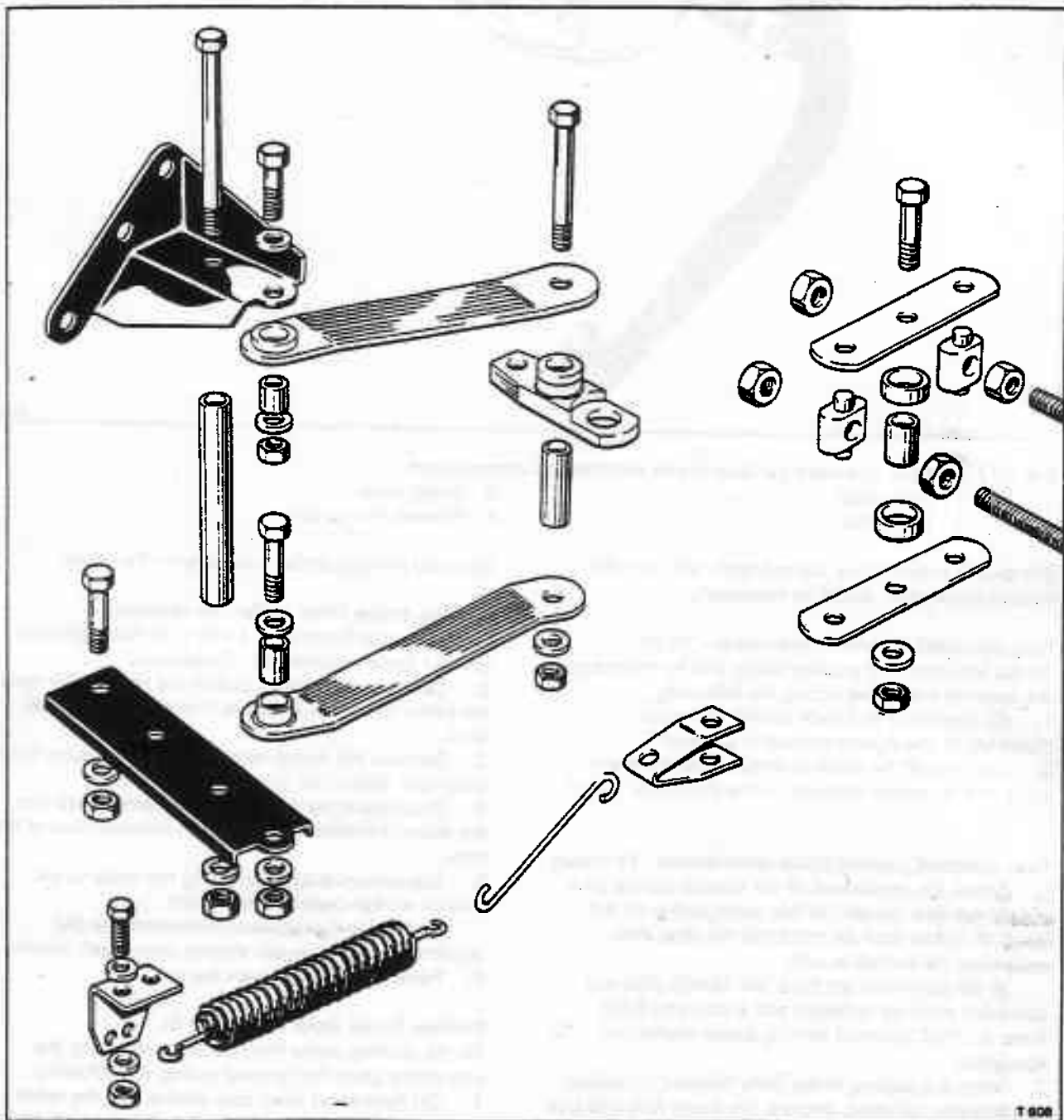

Fig. G17-4 Parking brake intermediate linkage

Parking brake rear cables - To fit

Fit the parking brake rear cables by reversing the procedure given for removal noting the following.

1. All setscrews and nuts should be torque tightened in accordance with the figures quoted in Chapter P.
2. Lubricate the clevis pins and cable adjustment threads with Rocol MTS 1000 grease or any suitable equivalent, prior to fitting.
3. Check the freedom of operation during the application and release of the parking brake. The parking brake should operate freely without roughness or binding throughout its operation.
4. Ensure that the cables are correctly located in the cable support clips and can move freely through them. Also, ensure that the cables are routed above the lower tube of the rear suspension space frame.
5. Adjust the cables as described under Parking brake cables and calipers - To adjust.

Parking brake cables and calipers - To adjust

Before any adjustments are made to the parking brake rear cables the caliper on each rear wheel should be set as follows.

1. Remove the clevis pin connecting the brake cable to the actuation lever.
2. Disconnect the actuation rod from the actuation lever.
3. Check and adjust if necessary the length of the actuation rod, to obtain a measurement of 57 mm (2.25 in) between the exposed face of the jaw lock-nut and the face of the opposite jaw.
4. Position the rod onto the actuation lever; fit the clevis pin, waved washer, and split pin. Lubricate the clevis pin with Rocol MTS 1000 grease or any suitable equivalent.
5. Ensure that the parking brake caliper is on its 'off stop'. Check that the clearance (see fig. G17-5, point A) between the washer on the spring guide rod and the spring abutment bracket is approximately 6 mm (0.25 in) at the point of minimum clearance. Bend the abutment bracket as necessary.

Note

The washer fitted to the end of the spring guide rod must not act as the parking brake 'off stop' as this will cause caliper pad misalignment.

6. Connect the rear brake cable to the actuation lever.
7. Ensure that the parking brake is in the fully 'off' position. Adjust the rear cables at the equalizer on the intermediate linkage until the caliper 'off stops' are just clear of the caliper. Measure the gap beneath each 'off stop' and lengthen the cables at the adjusters by this amount.

Note

The cables must be adjusted so that the equalizer transverse link lies at right angles to the centre line of the car with the parking brake in the 'off' position.

8. Raise each rear wheel in turn so that it is free to rotate. Turn the caliper adjuster clockwise until the parking brake pads grip the brake disc. At this point it should only just be possible to rotate the wheel by

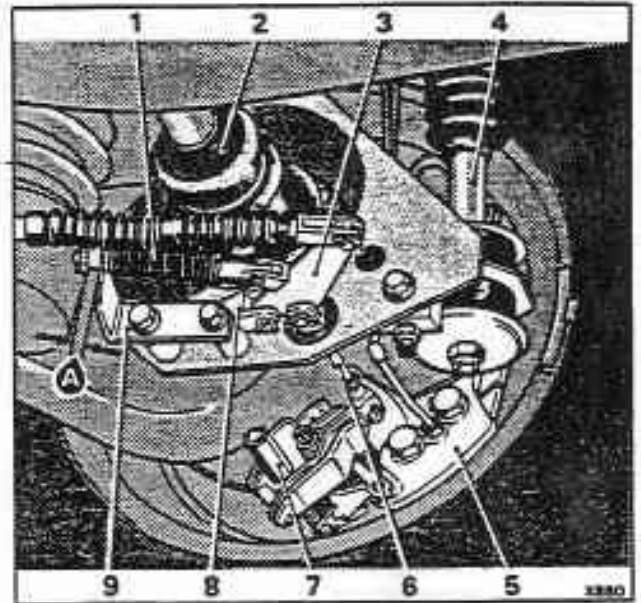

Fig. G17-5 Parking brake caliper and cable adjustment

- 1 Guide rod and return spring
- 2 Drive-shaft
- 3 Actuation lever
- 4 Suspension strut
- 5 Brake caliper
- 6 Actuation rod
- 7 Caliper adjuster
- 8 Mounting bracket
- 9 Spring abutment bracket

hand. Turn the adjuster anti-clockwise a quarter turn (three clicks on the nut) to obtain minimum clearance between the pads and disc.

9. Ensure that the centralizing straps are forcing the pads away from the disc when the parking brake is in the 'off' position. If not, remove the retaining bolt securing the straps; bend the straps outwards then re-assemble.

10. When new brake pads have been fitted carry out the pad bedding operation as described under Parking brake pads - To 'bed in'.

Parking brake pads - To renew (see fig. G17-6)

1. Securely chock the front wheels.
2. Raise the rear of the car. Place sill blocks under the rear end of the body sills. Support the trailing arms; do not allow the suspension struts to support the full suspension load.
3. Remove the rear wheels.
4. Release the parking brake to the 'off' position.
5. Disconnect the caliper actuation rod from the caliper lever.
6. Unscrew and remove the caliper adjuster. Collect the adjuster clicker block.
7. Unhook the pad retention springs from each brake pad; note that the larger spring is fitted to the inner parking brake pad.
8. Lift out the parking brake pads from the caliper and remove the retention springs.

Brake and height control hydraulic systems

Systematic check sequence chart.

Sheet 1 of 2



Operation 1

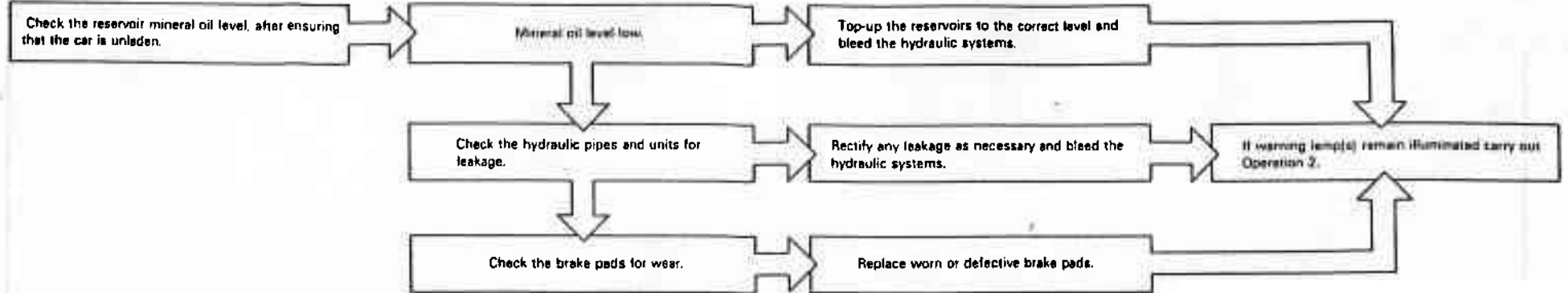

Operation 2

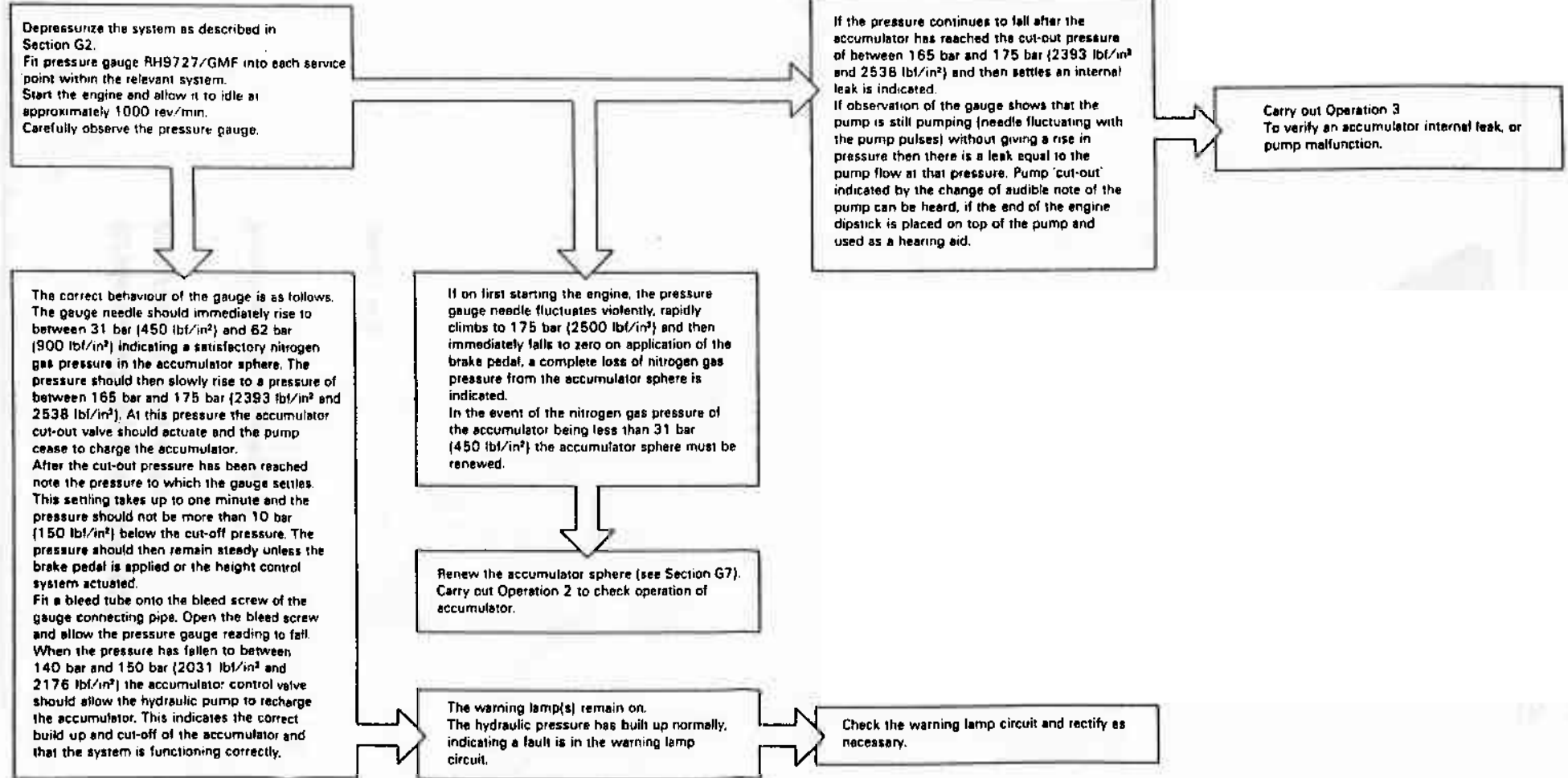

Brake and height control hydraulic systems

Systematic check sequence chart.

Sheet 2 of 2

Operation 3

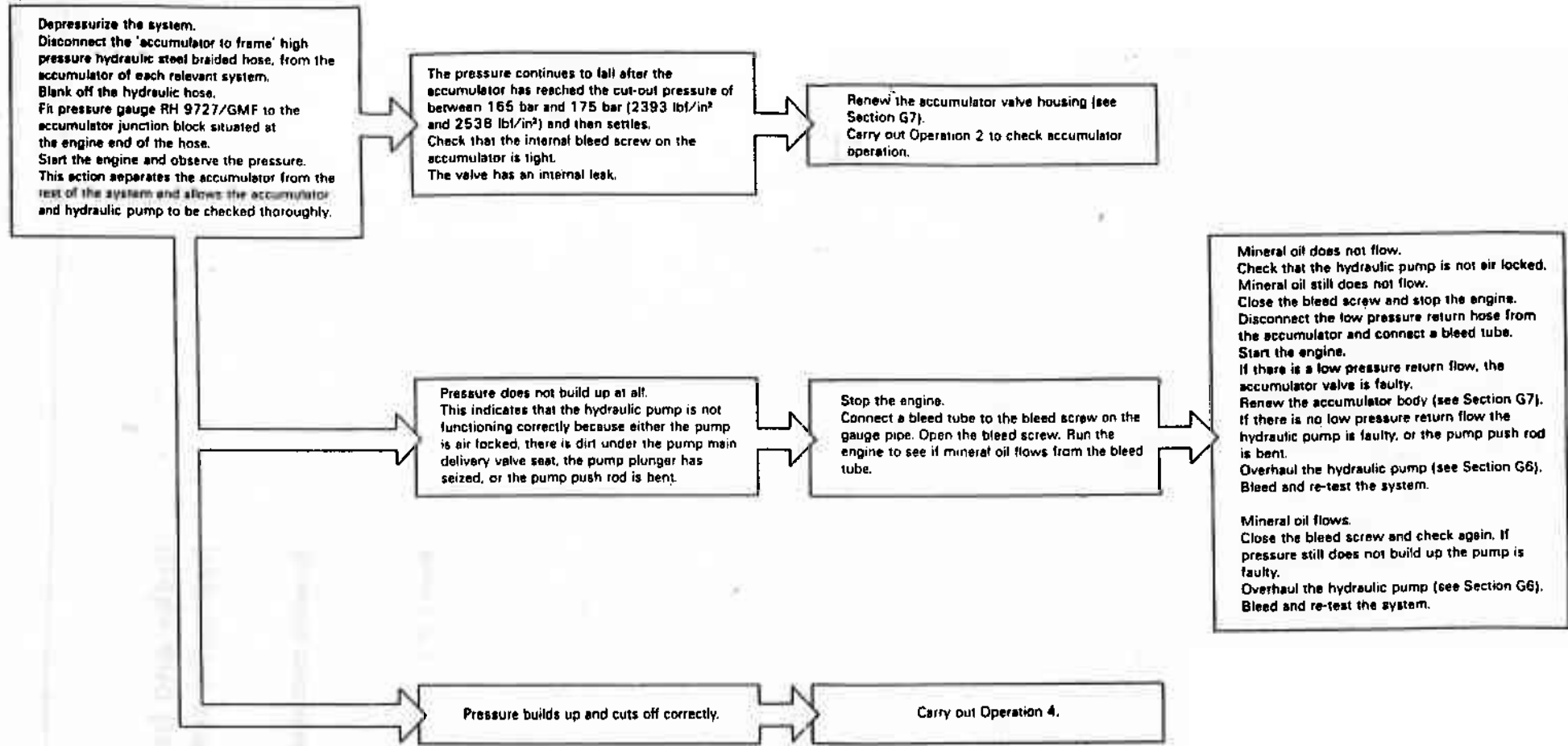

Operation 4

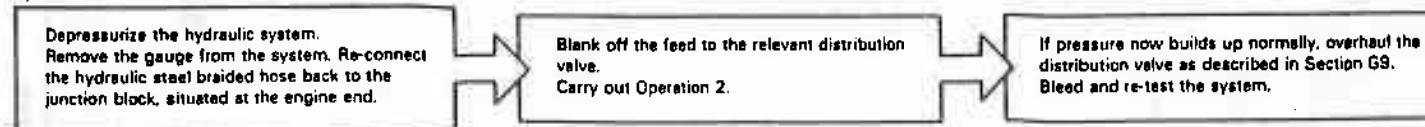

Isolating procedure – Series levelling rear suspension (4-door cars only)

Bentley Turbo R and cars from 1986 model year and onwards (other than Rolls-Royce cars destined for Japan and North America)

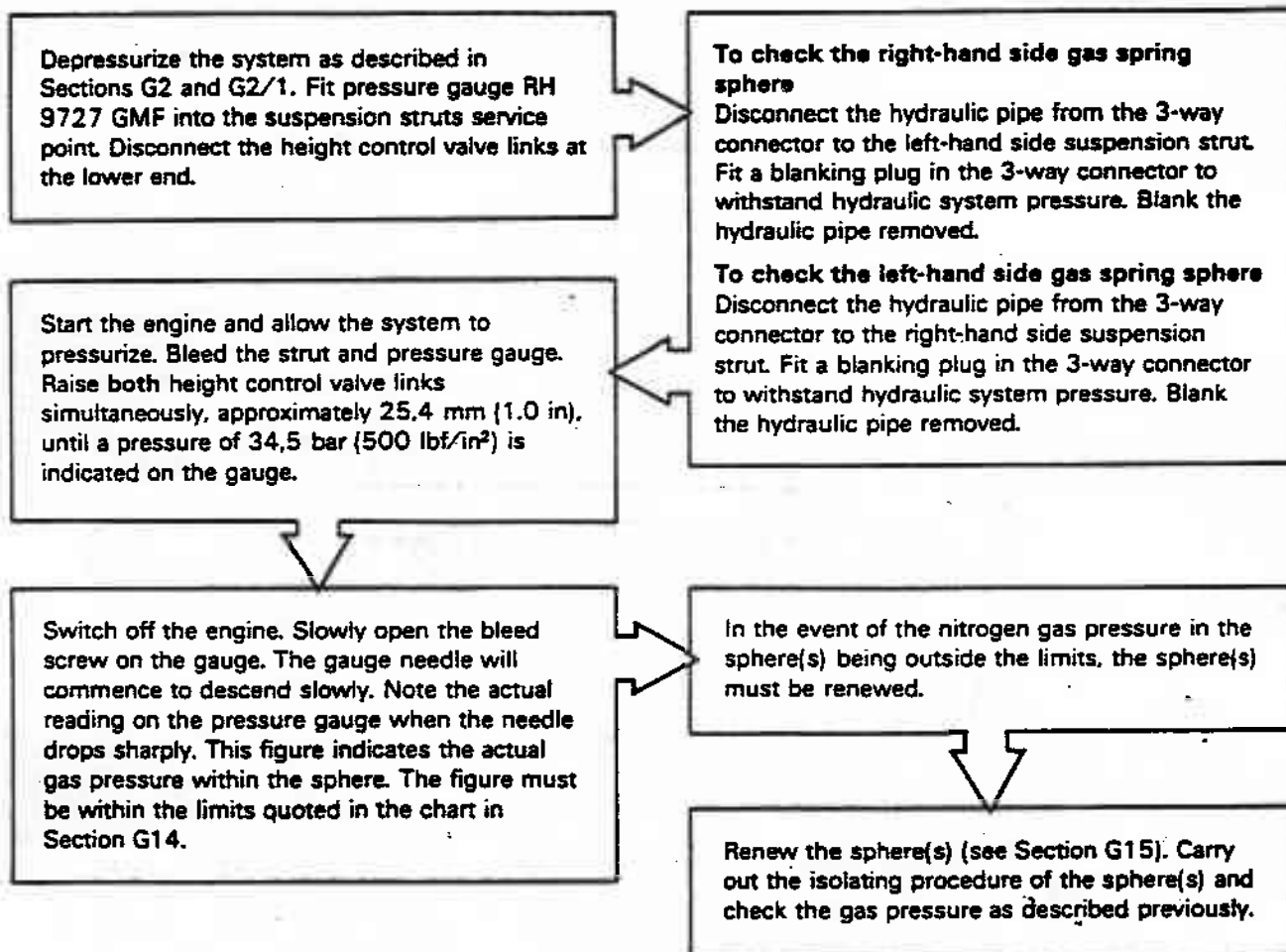

Special torque tightening figures

Introduction

This section contains the special torque tightening figures applicable to Chapter G.

For standard torque tightening figures refer to Chapter P.

Components used during manufacture of the vehicle have different thread formation (Metric, UNF, UNC, etc.). Therefore, when fitting nuts, bolts, and screws it is important to ensure that the correct type and size of thread formation is used.

Section G5

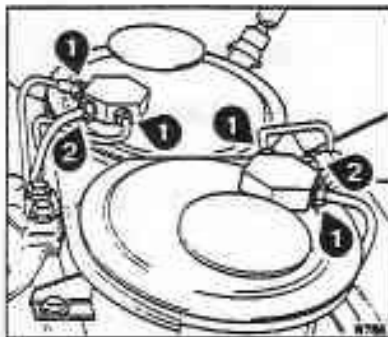

Ref.	Component	Nm	kgf m	lbf ft
1	Hydraulic pipes (3/16 in dia.) 3/8 in dia. UNF No.1 and No.2 systems	8 - 9	0,83-0,97	6 - 7
2	Hydraulic pipes (1/4 in dia.) 3/8 in dia. UNF No.1 and No. 2 systems	11 - 14	1,11-1,38	8 - 10

Section G6

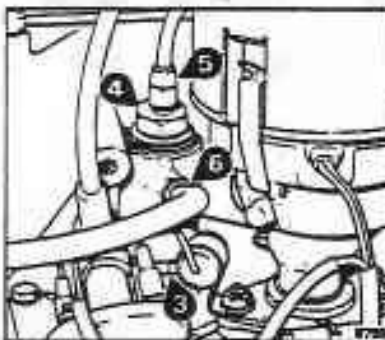

3	Castellated nut - Brake pump to engine	43 - 47	4,43-4,84	32 - 35
4	Adapter (Hexagon) - Brake pump	68 - 75	6,92-7,61	50 - 55
	Adapter (Non-hexagon) - Brake pump	61 - 75	6,23-7,61	45 - 55
4a	Lock-nut - Adapter to brake pump	20 - 33	2,08-3,45	15 - 25
5	Pipe nuts - Brake pump to accumulator	11 - 14	1,11-1,38	8 - 10
6	Pipe nuts - Brake pump inlet pipe	16 - 20	1,66-2,07	12 - 15

Section G7

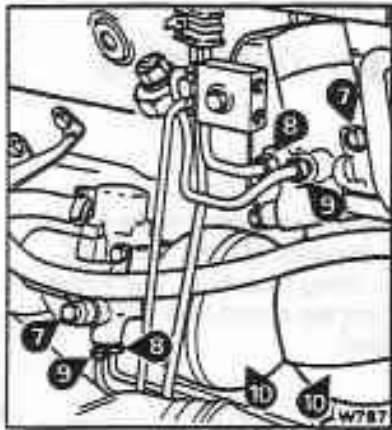

Ref.	Component	Nm	kgf m	lbf ft
7	Bleed screws	8 - 9	0,83-0,97	6 - 7
8	Pipe nuts - High pressure inlet from pump No.1 and No. 2 systems	9 - 11	0,97-1,11	7 - 8
9	Pipe nuts - High pressure outlet to upper distribution valve, right-hand and left-hand suspension strut	8 - 9	0,83-0,97	6 - 7
10	Sphere to accumulator body	25 - 44	2,49-4,56	18 - 33

Section G8

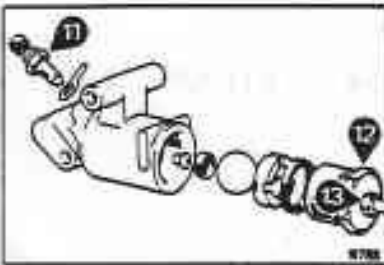

11	Bleed screw	8 - 9	0,83-0,97	6 - 7
12	End plug - 'G' conscious limiting valve	34 - 47	3,18-4,84	23 - 35
13	Pipe nuts - Conscious limiting valve (3/16 in dia.) 1/2 in dia. UNF	8 - 9	0,83-0,97	6 - 7

Section G9

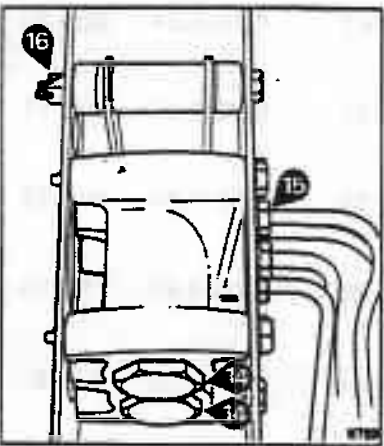

14	End plug - Distribution valve	82 - 88	8,30-8,99	60 - 65
15	Pipe nuts - Distribution valve (3/16 in dia.) 1/2 in dia. UNF	8 - 9	0,83-0,97	6 - 7
16	Castellated nuts - Distribution valve mounting	11 - 13	1,11-1,38	8 - 10

Section G11

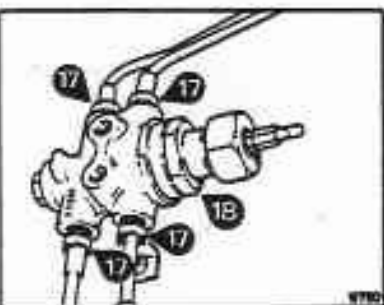

17	Pipe nuts - Priority valve/ pressure switch (3/16 in dia.) 1/2 in dia. UNF	8 - 9	0,83-0,97	6 - 7
18	Switch housing	16 - 20	1,66-2,07	12 - 15

Section G12

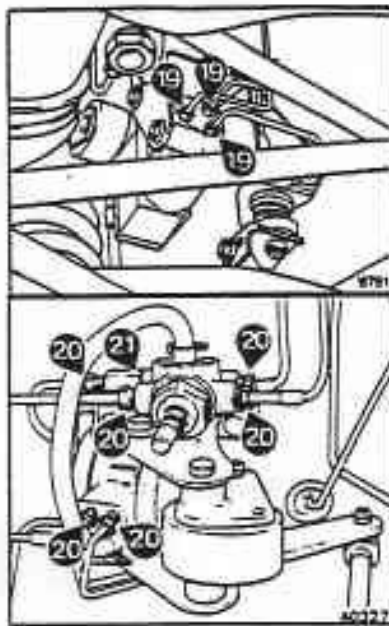

Ref.	Component	Nm	kgf m	lbf ft
19	Pipe nuts - Height control valve/restrictor (3/16 in dia.) 3/8 in dia. UNF	8 - 9	0,83-0,97	6 - 7
20	Pipe nuts - Height control valve	8 - 9	0,83-0,97	6 - 7
21	Restrictor	9 - 11	0,97-1,11	7 - 8

Section G13

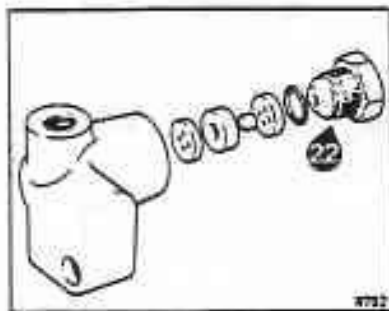

22	Restrictor adapter - Height control	30 - 33	3,04-3,46	22 - 25
----	-------------------------------------	---------	-----------	---------

Section G14

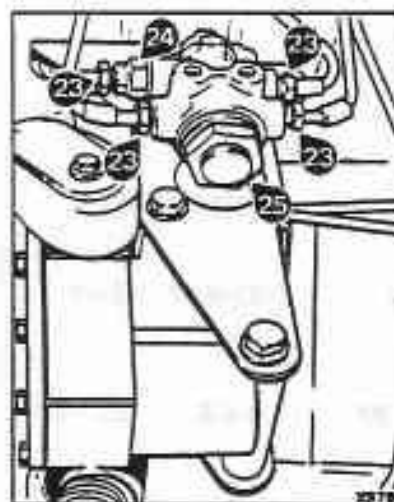

23	Pipe nuts - Minimum pressure valve (3/16 in dia.) 3/8 in dia. UNF	8 - 9	0,83-0,97	6 - 7
24	Restrictor - Minimum pressure valve	9-11	0,97-1,11	7 - 8
25	Blanking plug	16 - 20	1,66-2,07	12 - 15

Section G15

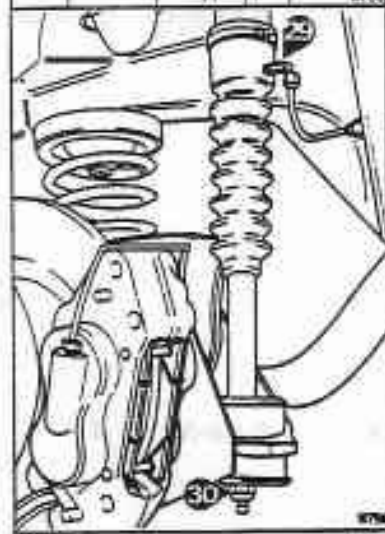
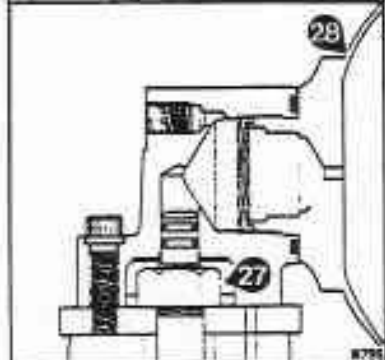
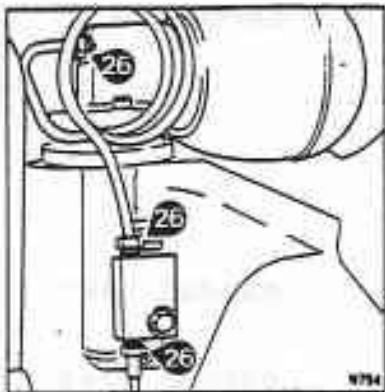

Ref.	Component	Nm	kgf m	lbf ft
26	Pipe nuts - Pressure supply pipe (7/16 in dia.) 3/8 in dia UNF	8 - 9	0,83-0,97	6 - 7
27	Strut retaining nut - Suspension strut mounting	55 - 58	5,53-5,95	40 - 43
28	Sphere - Gas spring	25 - 44	2,50-4,56	18 - 33
29	Pipe nut - Seepage return pipe (7/16 in dia.) 3/8 in dia. UNF	8 - 9	0,83-0,97	6 - 7
30	Self-locking nut - Strut piston rod to trailing arm	40 - 43	4,01-4,43	29 - 32

Section G16

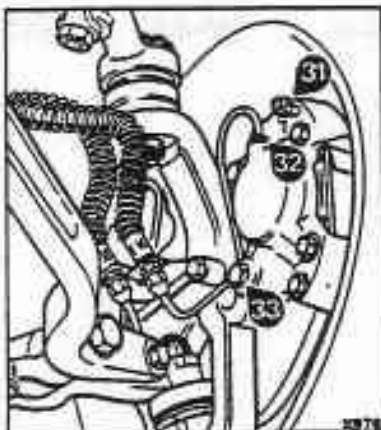

31	Bleed screw - Front wheel caliper	8 - 9	0,83-0,97	6 - 7
32	Pipe nut - Front wheel brake pressure supply pipe (7/16 in dia.) 3/8 in dia. UNF	8 - 9	0,83-0,97	6 - 7
33	Bolt - Caliper to stub axle 7/16 in dia UNF	75 - 81	7,6-8,3	55 - 60

Section G16

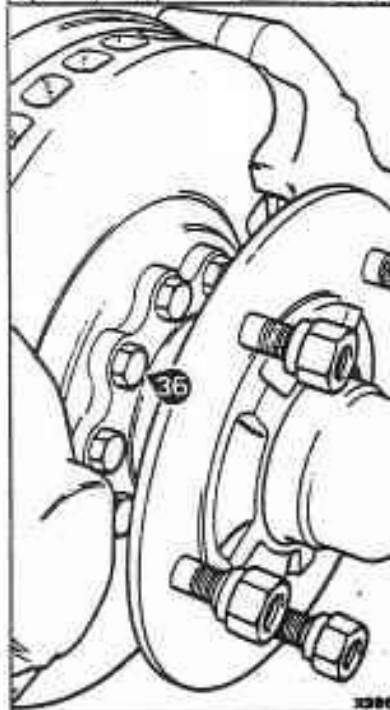
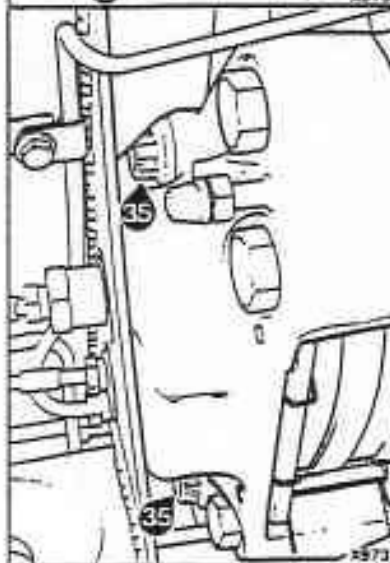
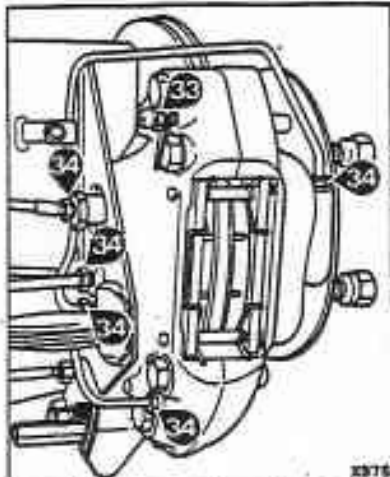

Ref.	Component	Nm	kgf m	lbf ft
33	Bleed screw - Rear wheel caliper	8 - 9	0,83-0,97	6 - 7
34	Pipe nuts - Hydraulic pipes ($\frac{7}{16}$ in dia.) $\frac{1}{2}$ in dia UNF	8 - 9	0,83-0,97	6 - 7
35	Bolt - Caliper to stub axle $\frac{1}{2}$ in dia UNF	109 - 115	11,0-11,7	80 - 85
36	Setscrews - Front brake disc to hub	43 - 48	4,43-4,96	32 - 36

Workshop tools

Tool Number	Description
RH 8428	Special box spanner - Hydraulic pump
RH 9727/GMF	Pressure gauge - Hydraulic system mineral oil (LHM)
RH 9813	Spanner - Lock-nut - Hydraulic pump
RH 9844	Special box spanner - Hydraulic pump