

## **Windscreen wipers and washers**

OFF position 1

Wiring diagram and circuit description

### Circuit description

#### OFF position

With the windscreen wiper control switch in the OFF position, switch contacts 1 and 2 are closed. If the screen wiper system is operating and OFF position is then selected the wiper motor continues to rotate until the motor sets the Park position. This breaks the 12 volts positive supply to the coil of relay 1, thereby de-energizing the relay and removing the 12 volts positive supply from the slow speed brush of the wiper motor. The supply to the motor is routed from fuse 5 at the dashboard via right-hand toolbar plug B and also the connection at relay 2 socket.

The slow speed brush of the wiper motor now finds an earth path through the normally closed contacts of relays 3 and 1, and via connections at relay sockets 1, 2, and 3 to the valance earth point.

The coil of relay 2 receiving 12 volts positive from wiper switch contact 2, finds an earth path via the Park position of the Park off screen switch thereby re-energizing relay 2. This provides a 12 volts positive supply through the normally open contacts to the wiper motor. The motor reverses direction causing the Park off screen switch to be set to the Park position. This disconnects the earth path causing the motor to stop with the windscreen wiper blades in the parked position.

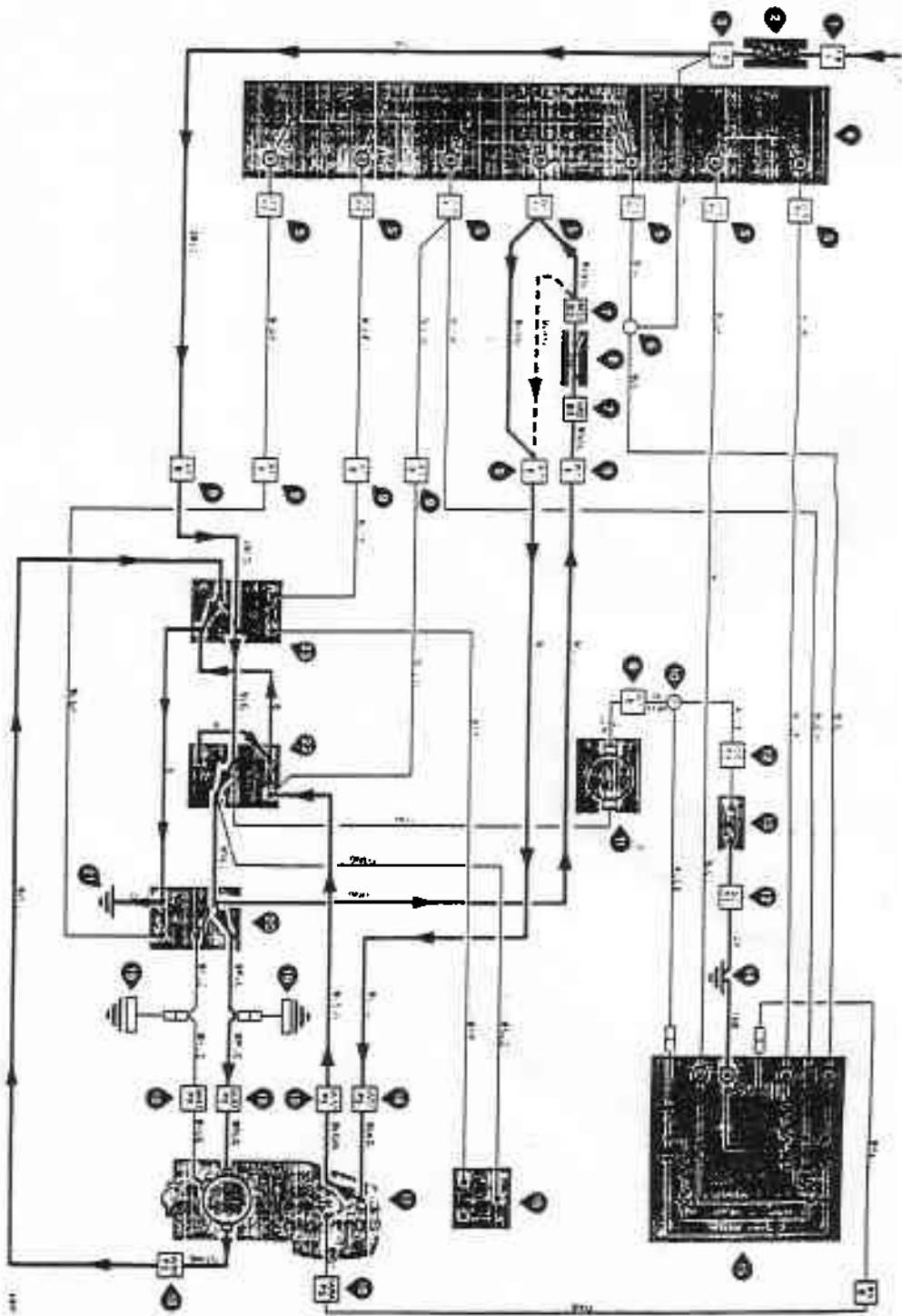

## Windscreen wipers and washers

OFF position 2

Wiring diagram and circuit description

**Circuit description**

**Off position**

With the windscreen wiper control switch in the Off position switch contacts 1 and 2 are closed. If the screen wiper system is operating and Off position is then selected the wiper motor continues to rotate until the motor sets the Park position. This breaks the 12 volts positive supply to the Park of relay 1, thereby de-energizing the relay and removing the 12 volts positive supply from the slow speed brush of the wiper motor. This supply to the motor is routed from fuse 5 at the dashboard via right-hand foreboard plug B and also the connection at relay 2 socket.

The slow speed brush of the wiper motor now finds an earth path through the normally closed contacts of relays 3 and 1, and via connections at relay sockets 1, 2 and 3 to the valve earth point.

The coil of relay 2, receiving 12 volts positive from wiper switch contact 2, finds an earth path via the Run position of the Park off screen switch, thereby energizing relay 2. This provides a 12 volts positive supply through the normally open contacts to the wiper motor. The motor reverses direction causing the Park off screen switch to be set to the Park position. This disconnects the earth path causing the motor to stop with the windscreen wiper blades in the parked position.

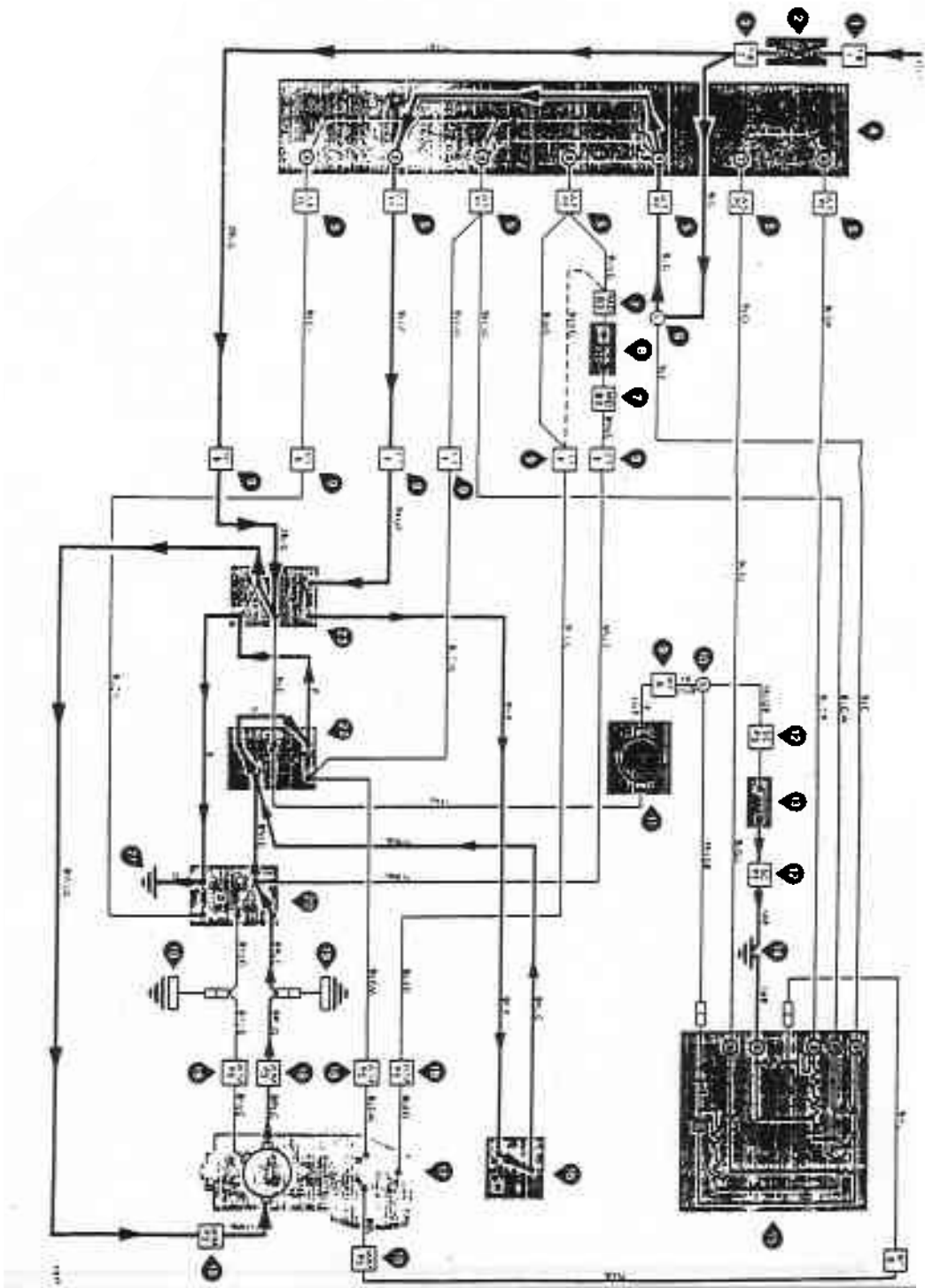

## Windscreen wipers and washers

SLOW position

Wiring diagram and circuit description

**Circuit description**

**SLOW speed position**

With the windscreen wiper control switch in the SLOW position, switch contacts 1 and 3 are closed. A 12 volts positive supply from fuse 5 at the fuseboard is directed through switch contacts 1 and 3 to energise relay 1. This allows a 12 volts positive supply to pass through the normally open contacts of relay 1 and via the normally closed contacts of relay 3 to the slow speed brush of the wiper motor. The supply is routed from fuse 5 at the fuseboard via right-hand toeboard plug B and also the connection at relay 2 socket. The earth path for the wiper motor is via the normally closed contacts of relay 2 and the connection at relay 3 socket, to the valence earth point.

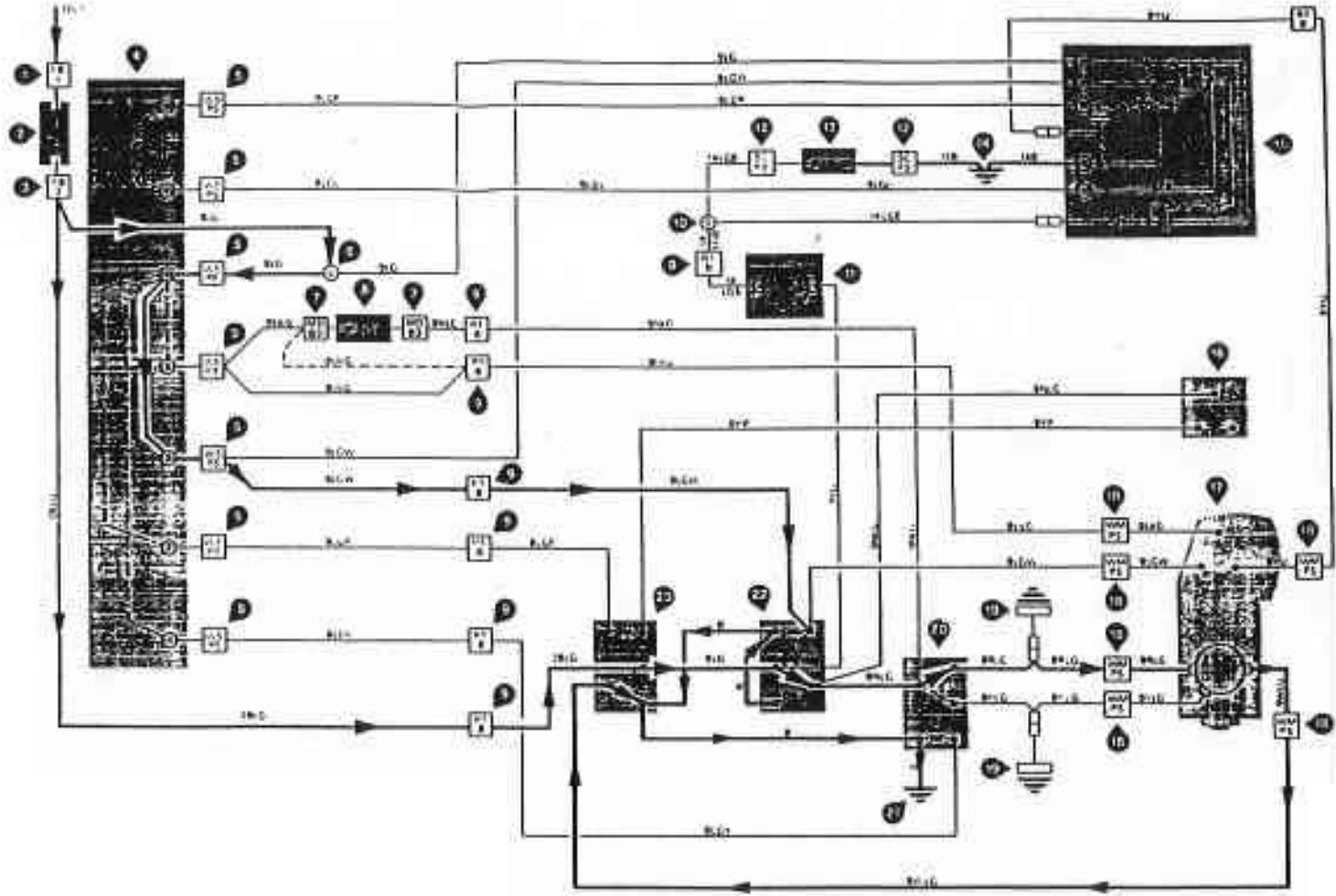

## **Windscreen wipers and washers**

**FAST position**

Wiring diagram and circuit description

**Circuit description**

**FAST position**

With the windshield wiper control switch set in the FAST position, switch contacts 1, 3, and 4 are closed. A 12 volt positive feed from fuse 5 at the fuseboard is directed via switch contacts 1 and 3 to energize relay 1 and close the normally open contacts. Simultaneously, switch contacts 1 and 4 supply 12 volts positive from fuse 5 to energize relay 3. With relays 1 and 3 energized, 12 volt positive is passed through the normally open contacts of the relays to the last speed brush of the wiper motor. This supply is routed from fuse 5 at the fuseboard via right hand terminal gang B and also the connection at relay 2 socket. The earth path for the wiper motor is via the normally closed contacts of relay 2 and the connection at relay 3 socket to the valence earth point.

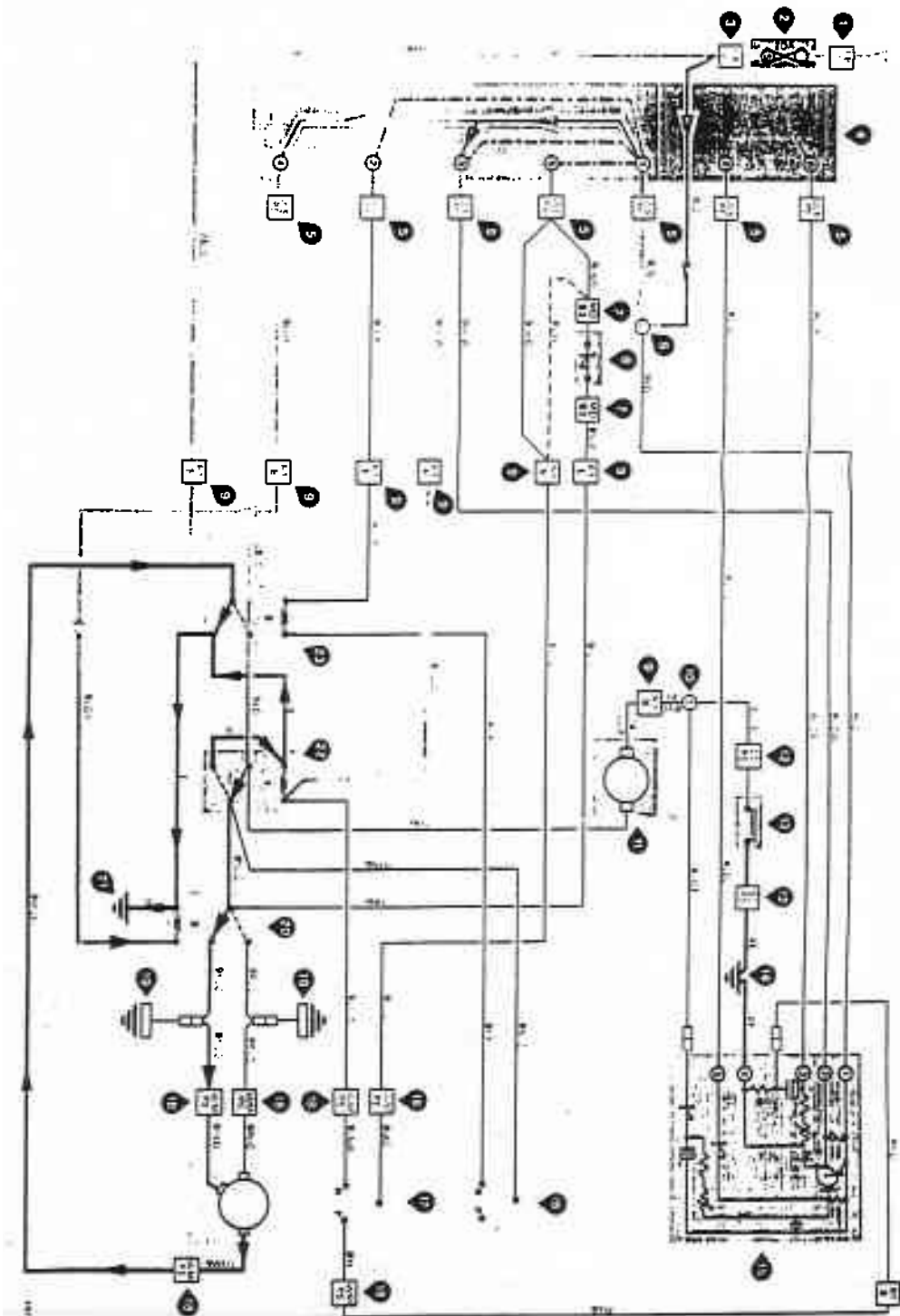

## Windscreen wipers and washers

INT (Intermittent) position

Wiring diagram and circuit description

**Circuit description**

**INT (Intermittent) wipe position**  
 With the windscreen wiper control switch in the INT (Intermittent) wipe position switch contacts 1 and 5 also 7 and 8 are closed.

When switch contacts 7 and 8 are closed the wiper system electronic control unit provides a momentary 12 volts positive supply at terminal 2 of the unit to energise the coil of relay 1. With relay 1 energised a 12 volts positive supply is directed to the normally open contacts of relay 3 and through the normally closed contacts of relay 3 to the slow speed brush of the wiper motor. This supply is routed from fuse 5 at the fuseboard via onboard plug B and also the connection at relay 2 socket. The earth path for the wiper motor is directed through the normally closed contacts of relay 2 and the connection at relay 3 socket to the variance earth point. The motor then rotates.

Immediately the motor rotates the Park on screen switch is set to the Run position and a 12 volts positive supply is fed via the Run position to maintain 12 volts positive at the coil of relay 1.

After one wipe cycle the wiper motor sets the Park on screen switch to the Park position, thus de-energising relay 1 and disconnecting the motor supply. The motor stops with the screen wiper blades in the Park on screen position.

After a delay of approximately seven seconds the electronic control unit of the system again sets a momentary 12 volts positive supply at terminal 2, causing the cycle to be repeated.

The intermittent wipe cycle continues until the windscreen wiper control switch is set to the OFF position.

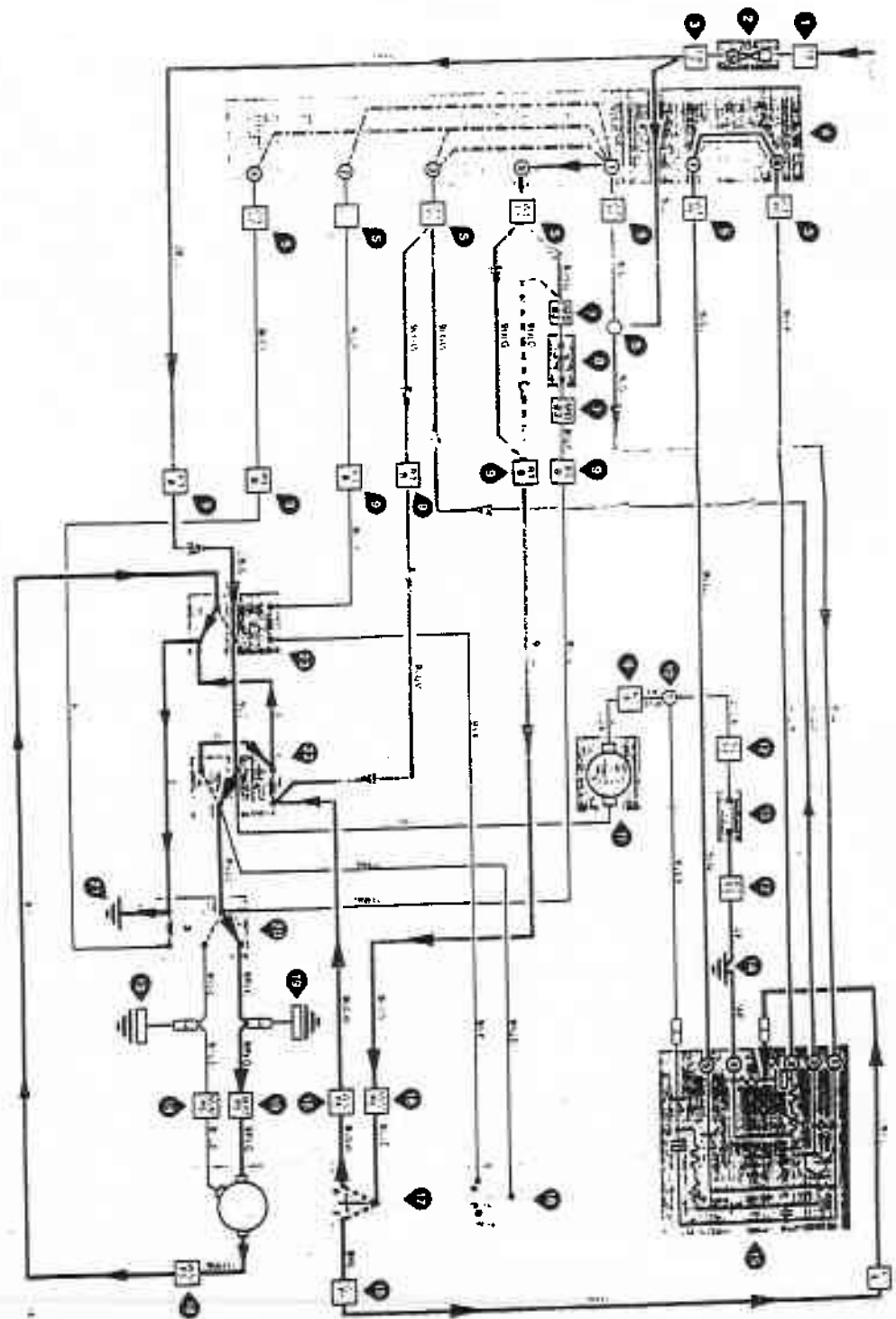

## Windscreen wipers and washers

Wash/Wipe mode

Wiring diagram and circuit description

### Circuit description

**Wash/wipe mode**  
With the ignition switch in the RUN or ACC position the screen washer pump receives a 12 volts positive supply from fuse 5 at the fuseboard. Depressing the wash/wipe switch on the steering column provides an earth path for the pump which then operates.

The wash/wipe switch also provides an earth path via splice connection 5 for the light green/black flying lead of the wiper system electronic control unit. This provides a 12 volts positive supply at terminal 2 of the control unit, energising relay 1 and thereby allowing 12 volts positive through the normally open contacts of relay 1, and through the normally closed contacts of relay 3, to the slow speed brush of the wiper motor. This supply is routed from fuse 5 at the fuseboard via lothead plug B and also the connection at relay 2 socket. The earth path for the wiper motor is directed through the normally closed contacts of relay 2 and the connection at relay 3 socket to the vehicle earth point.

On releasing the wash/wipe switch the screen wash pump stops immediately, but the wiper system control unit maintains the 12 volts positive supply at terminal 2 for a approximately five cycles, causing the wiper motor to complete approximately five cycles. The wipe cycle ends with the wiper blades in the parked position, details of which are shown in the diagrams for the OFF position.

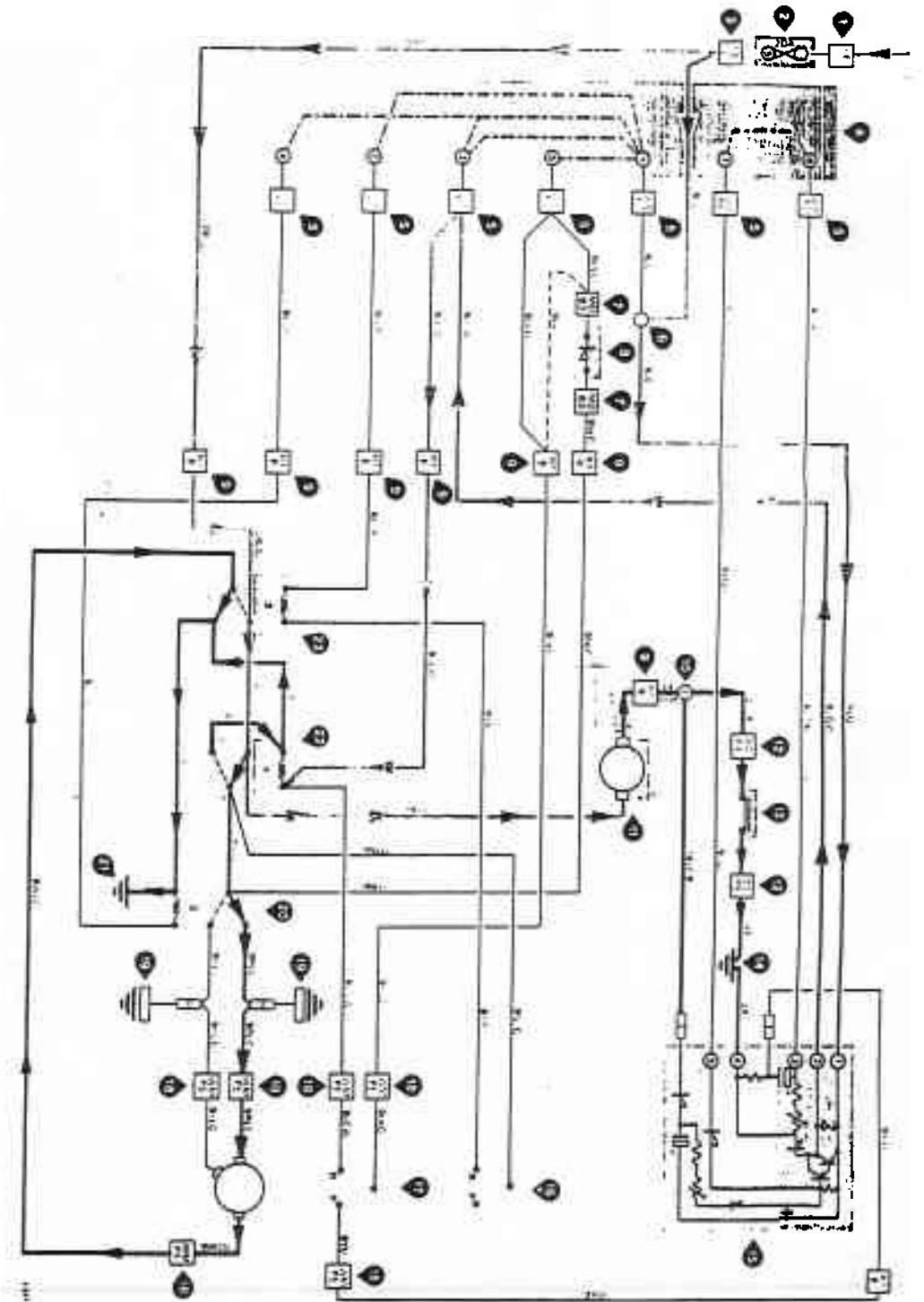

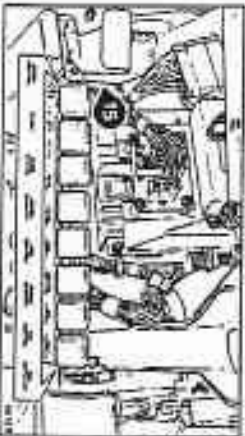
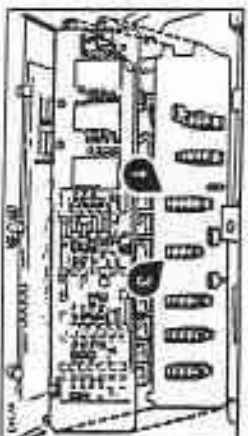
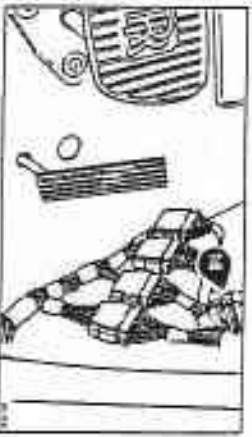
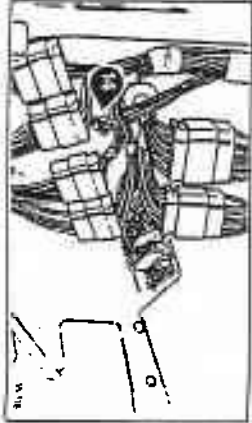
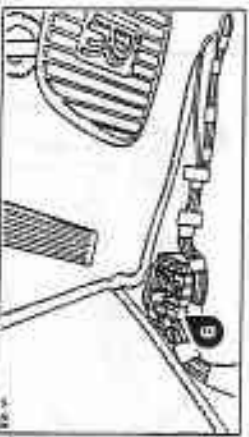
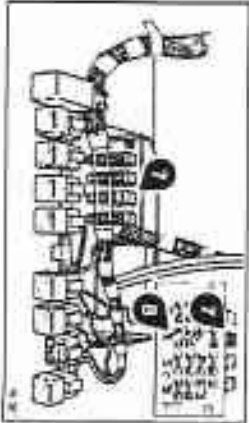
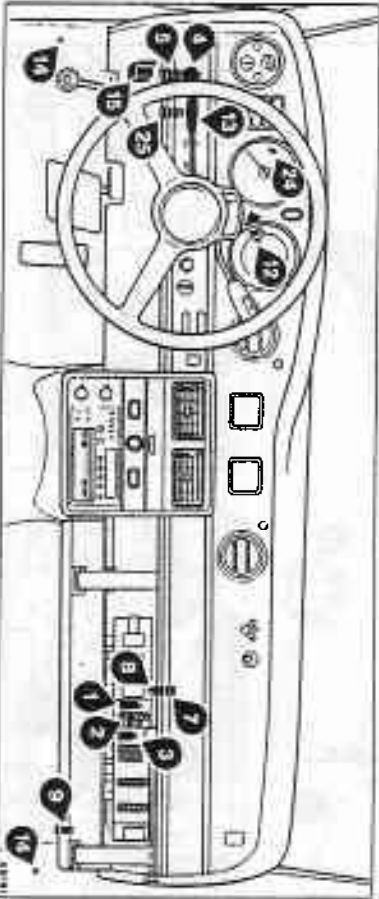
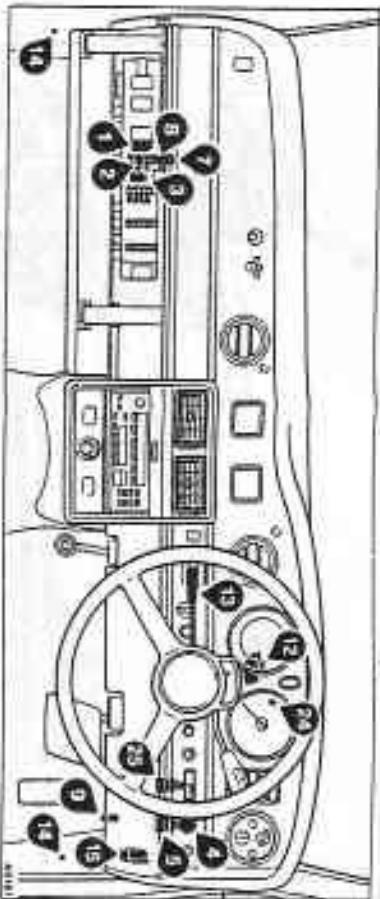

Callout	Part Name	Part Number
1	Instrument Cluster	141.08
2	Instrument Cluster	141.08
3	Instrument Cluster	141.08
4	Instrument Cluster	141.08
5	Instrument Cluster	141.08
6	Instrument Cluster	141.08
7	Center Console	141.08
8	Center Console	141.08
9	Center Console	141.08
10	Center Console	141.08
11	Center Console	141.08
12	Steering Wheel	141.08
13	Steering Wheel	141.08
14	Steering Wheel	141.08
15	Steering Wheel	141.08
16	Steering Wheel	141.08

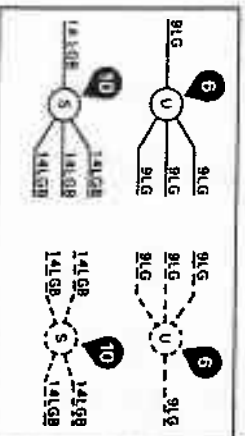
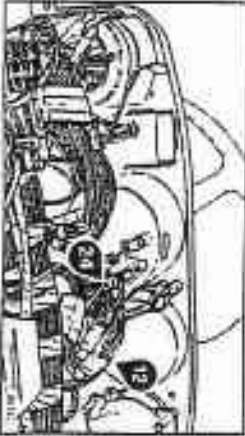
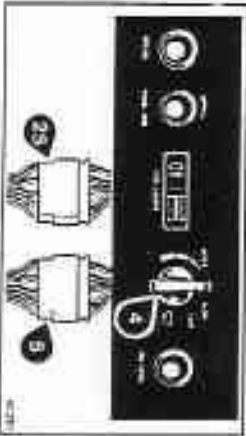

## **Windscreen wipers and washers**

INTER (Intermittent) positions

Wiring diagram and circuit description



# Windscreen wipers and washers

Comiche/Continental

Component location

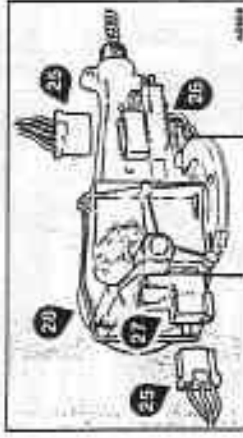
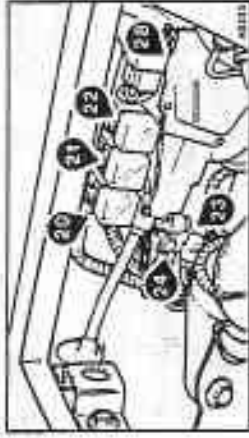
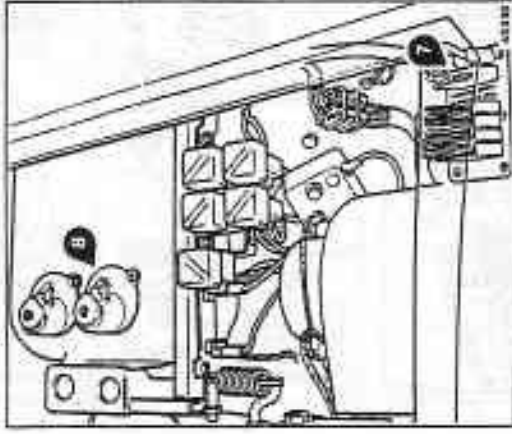
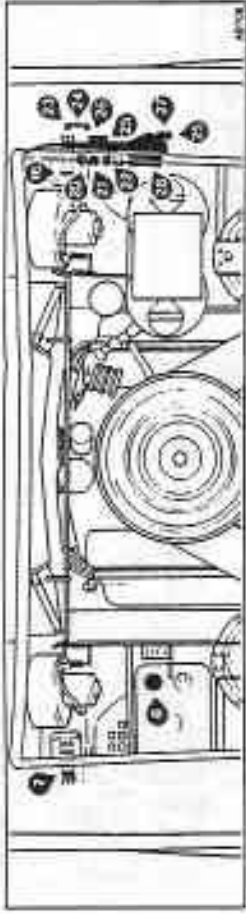



## **Windscreen wipers and washers**

**Corniche/Continental**

**OFF position 1**

**Wiring diagram and circuit description**

**Circuit description**

**OFF position**  
 With the windshield wiper control switch in the OFF position, switch contacts 1 and 2 are closed. If the screen wiper system is operating and OFF position is then selected, the wiper motor continues to rotate until the motor sets the 'Park' on screen switch within the motor assembly to the Park position. This breaks the 12 volt positive supply to the coil of relay 1, thereby de-energizing the relay and removing the 12 volt positive supply from the slow speed brush of the wiper motor. This supply to the motor is routed from fuse 5 at the fuseboard via right-hand inboard plug B and also the connection at relay 2 socket.

The slow speed brush of the wiper motor now looks an earth path through the normally closed contacts of relay 3 and 1, and via connections at relay sockets 1, 2, and 3 to the vehicle earth point.

The coil of relay 2 receives 12 volts positive from wiper switch contact 2, finds an earth path via the Run position of the 'Park off screen' switch, thereby energizing relay 2. This provides a 12 volts positive supply through the normally open contacts to the wiper motor. The motor is reverse direction causing the 'Park off screen' switch to be set to the Park position. This disconnects the earth path causing the motor to stop with the windshield wiper blades in the parked position.

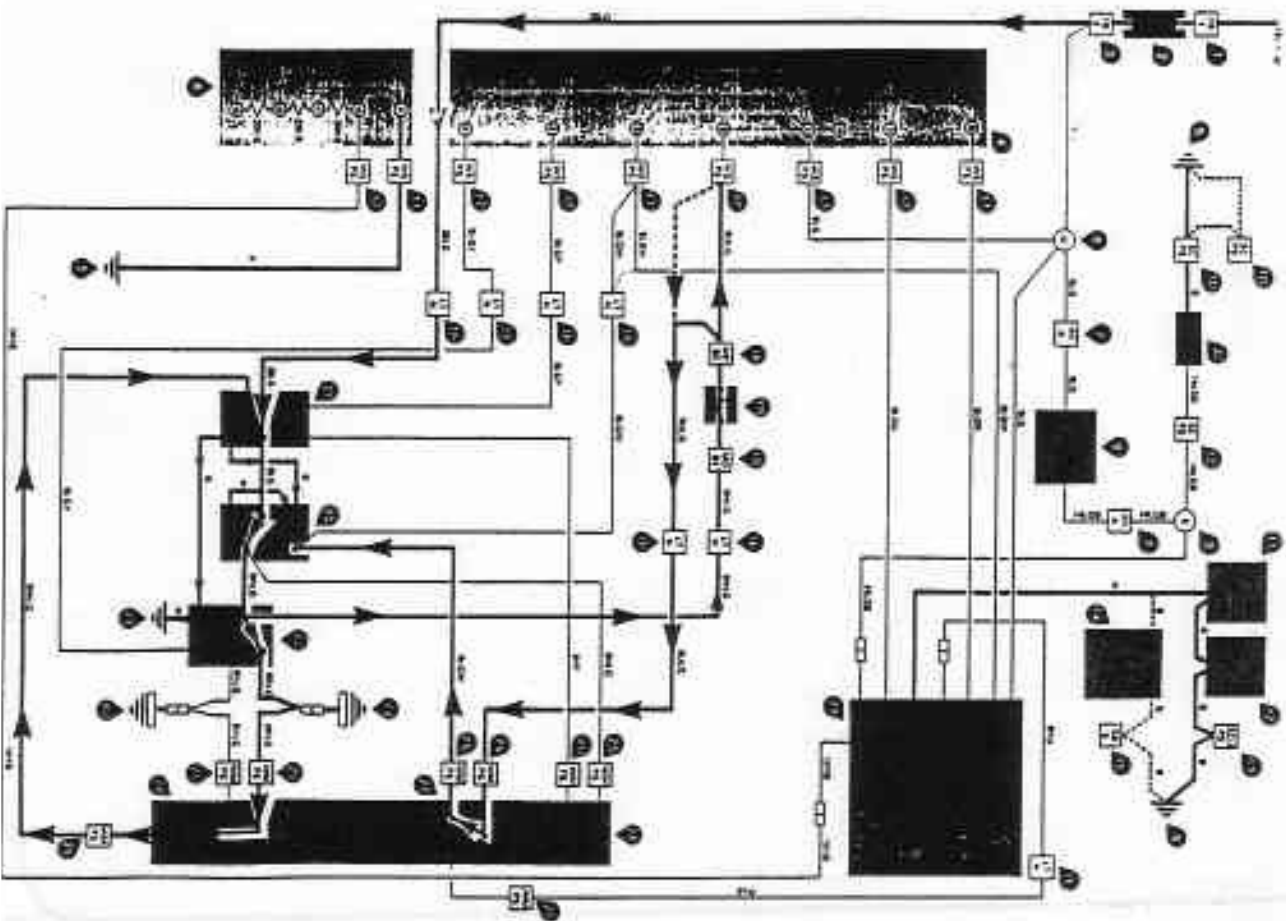

## **Windscreen wipers and washers**

**Corniche/Continental**

**OFF position 2**

**Wiring diagram and circuit description**

**Circuit description**

**OFF position**

With the windscreen wiper control switch in the OFF position, switch contacts 1 and 2 are closed. If the screen wiper system is operating and OFF position is then selected the wiper motor continues to rotate until the motor sets the 'Park on screen' switch (within the motor assembly) to the Park position. This breaks the 12 volts positive supply to the coil of relay 1, thereby de-energizing the relay and removing the 12 volts positive supply from the slow speed brush of the wiper motor. This supply to the motor is routed from fuse 5 at the fuseboard via right-hand toeboard plug B and also the connection at relay 2 socket.

The slow speed brush of the wiper motor now finds an earth path through the normally closed contacts of relays 3 and 1, and via connections at relay sockets 1, 2, and 3 to the valance earth point.

The coil of relay 2 receiving 12 volts positive from wiper switch contact 2, finds an earth path via the Run position of the 'Park off screen' switch, thereby energizing relay 2. This provides a 12 volts positive supply through the normally open contacts to the wiper motor. The motor reverses direction, causing the 'Park off screen' switch to be set to the Park position. This disconnects the earth path causing the motor to stop with the windscreen wiper blades in the parked position.

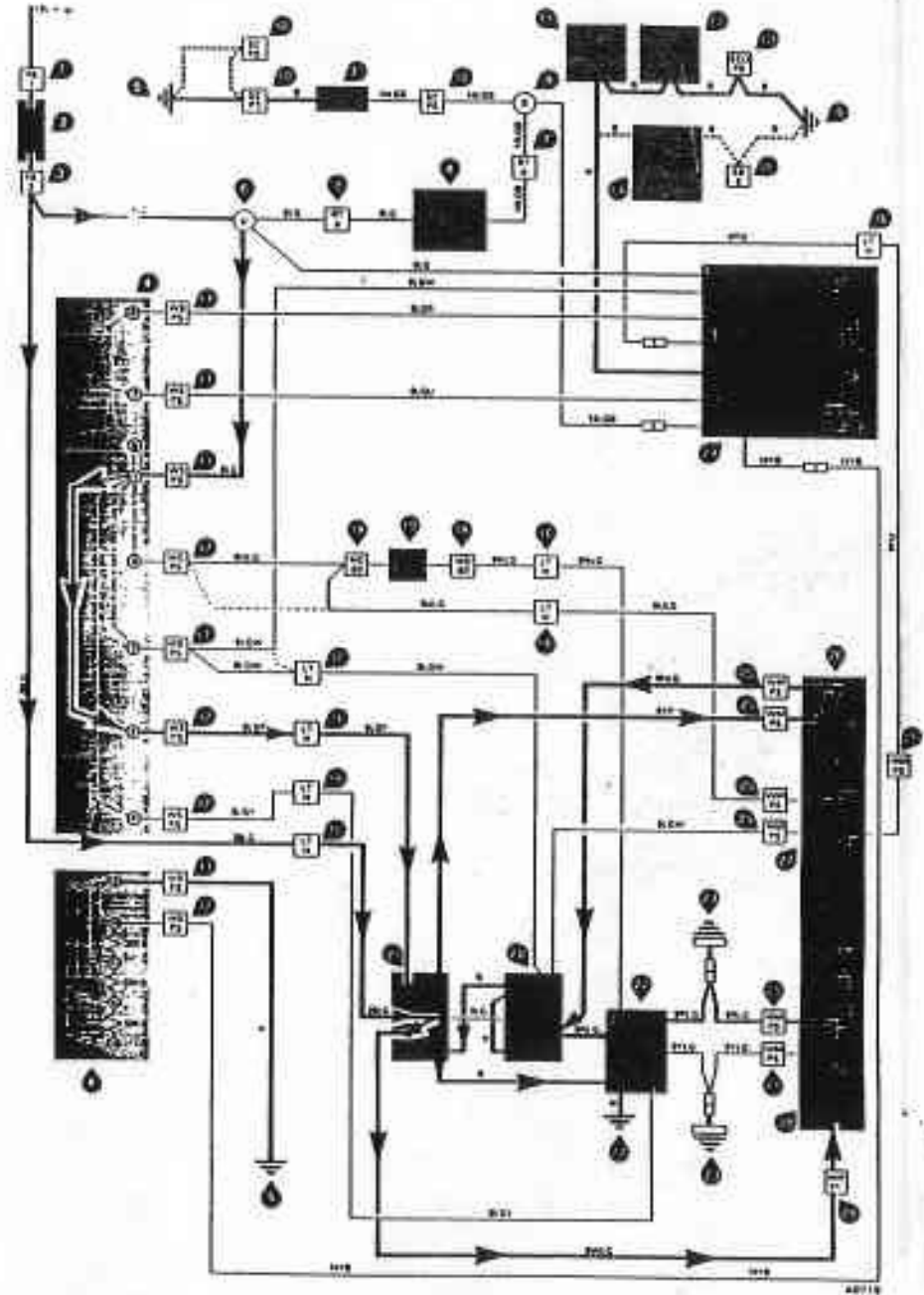

**Facia stowage compartment,  
fuseboard, luggage  
compartment, and engine  
compartment illumination**

Component location

1. Gear Shift  
 2. Handbrake  
 3. Gear Shift Lock  
 4. Gear Shift Lock Release  
 5. Gear Shift Lock Release Button  
 6. Gear Shift Lock Release Button  
 7. Gear Shift Lock Release Button  
 8. Gear Shift Lock Release Button  
 9. Gear Shift Lock Release Button  
 10. Gear Shift Lock Release Button  
 11. Gear Shift Lock Release Button  
 12. Gear Shift Lock Release Button  
 13. Gear Shift Lock Release Button  
 14. Gear Shift Lock Release Button  
 15. Gear Shift Lock Release Button

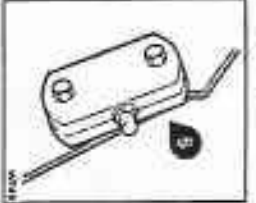
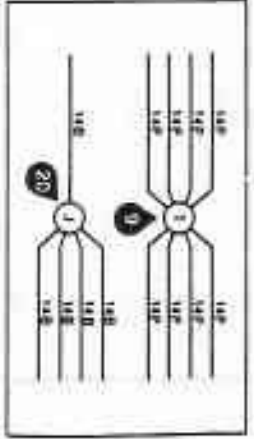
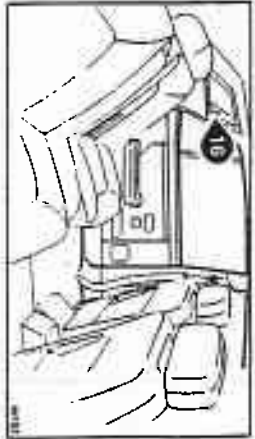
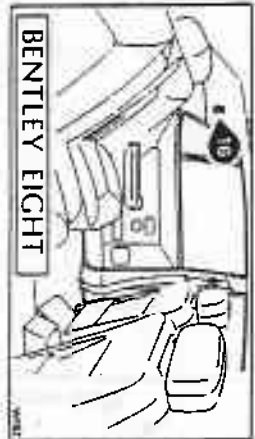
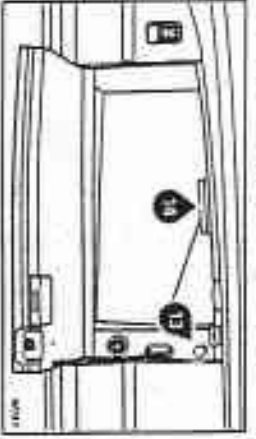
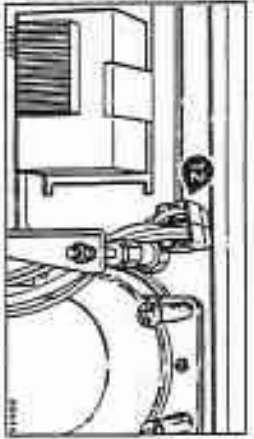
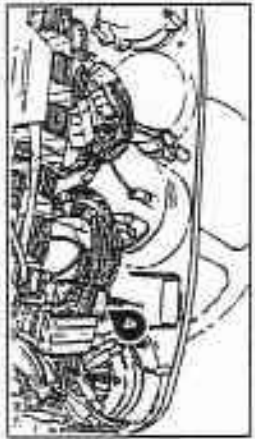
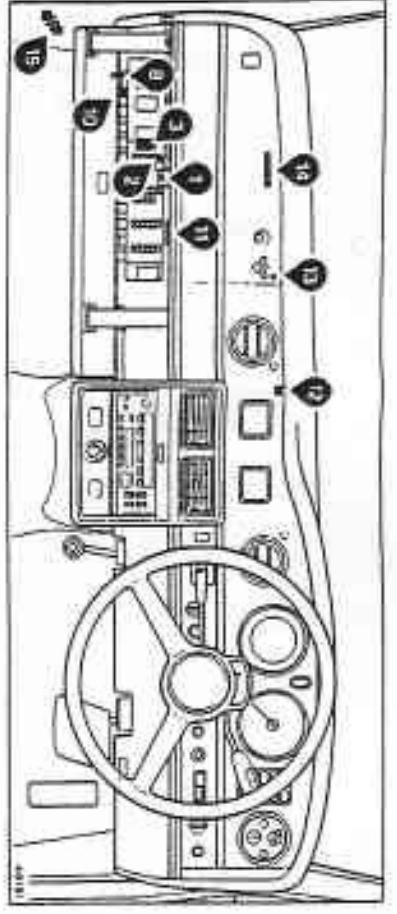
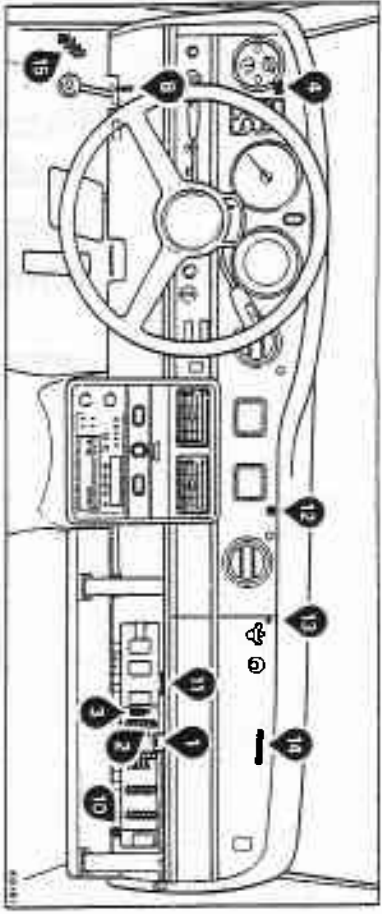
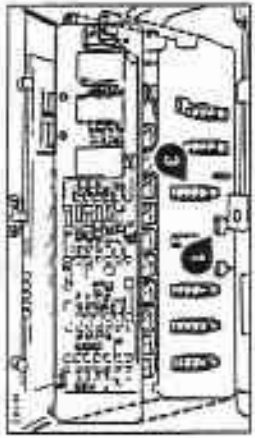
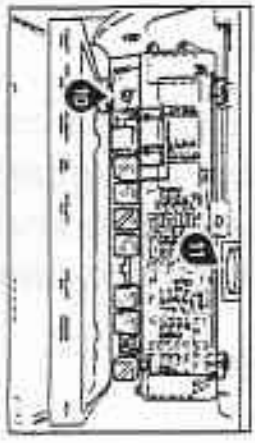

## **Windscreen wipers and washers**

**SLOW position**

Wiring diagram and circuit description

**Circuit description**

**FAST position:** With the windscreen wiper control switch set in the FAST position, switch contacts 1, 3 and 4 are closed. A 12 volt positive feed from fuse 5 at the fuseboard is directed via switch contact 1 and 2 to energise relay 1 and close the normally open contacts. Simultaneously switch contacts 1 and 4 supply 12 volts positive from fuse 5 to energise relay 3. With relays 1 and 3 energised 12 volts positive is passed through the normally open contacts of the relays to the fast speed brush of the wiper motor. This supply is routed from fuse 5 at the fuseboard via right-hand toolbar plug B and also the connection at relay 2 socket. The earth path for the wiper motor is via the normally closed contacts of relay 2 and the connection at relay 3 socket to the valence earth point.

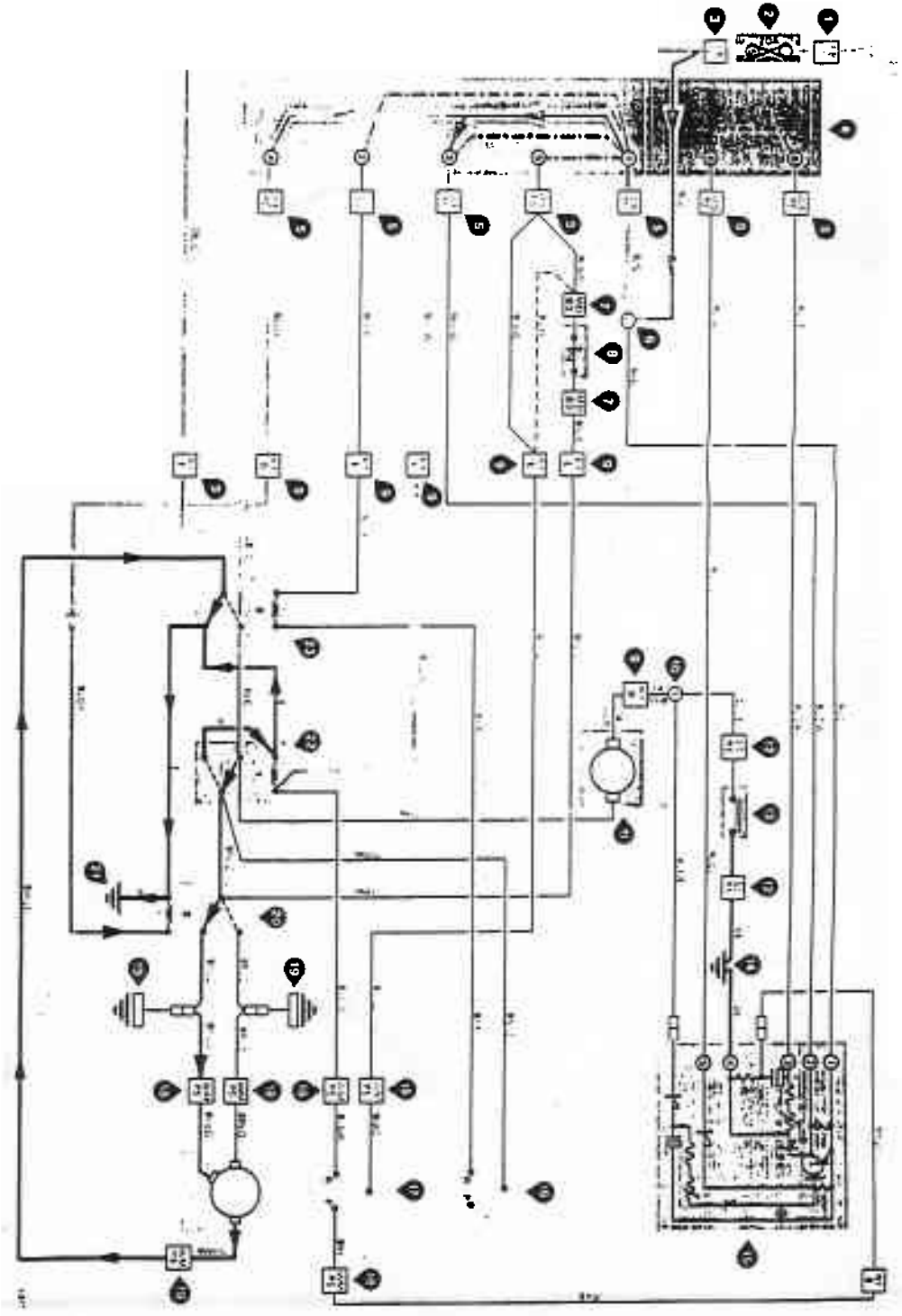

## **Windscreen wipers and washers**

**FAST position**

Wiring diagram and circuit description

**Circuit description**

**FAST position**  
With the windscreen wiper control switch set in the FAST position, switch contacts 1, 3, and 4 are closed. A 12 volt positive lead from fuse 5 at the fuseboard is directed via switch contacts 1 and 3 to energize relay 1 and close the normally open contacts. Simultaneously switch contacts 1 and 4 supply 12 volts positive from fuse 5 to energize relay 3. With relay 1 and 3 energised 12 volts positive is passed through the normally open contacts of the relay to the speed brush of the wiper motor. This supply is routed from fuse 5 at the fuseboard via right hand forward plug B and also the connection at relay 2, socket. The earth path for the wiper motor is via the normally closed contacts of relay 2 and the connection at relay 3 socket to the valance earth point.

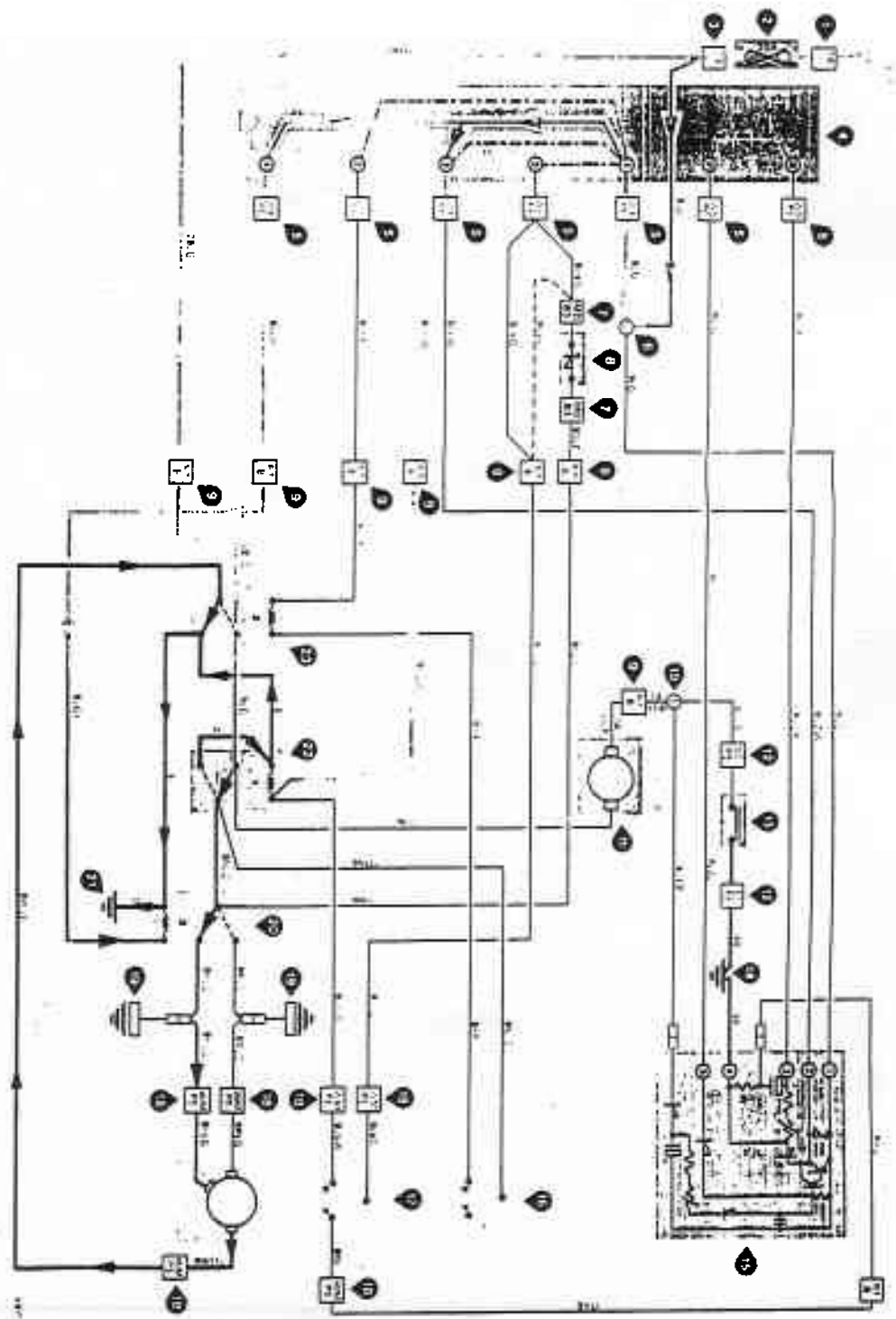

## Windscreen wipers and washers

INT (Intermittent) position

Wiring diagram and circuit description

**Circuit description**

**INT (Intermittent) wipe position**

With the windscreen wiper control switch in the INT (Intermittent) wipe position switch contacts 1 and 5 also 7 and 8 are closed.

When switch contacts 7 and 8 are closed the wiper system electronic control unit provides a momentary 12 volts positive supply at terminal 2 of the unit to energise the coil of relay 1. With relay 1 energised a 12 volts positive supply is directed to the normally open contacts of relay 1 and through the normally closed contacts of relay 3 to the slow speed brush of the wiper motor. This supply is routed from fuse 5 at the fuseboard via toeboard plug B and also the connection at relay 2 socket. The earth path for the wiper motor is directed through the normally closed contacts of relay 2 and the connection at relay 3 socket to the valence earth point. The motor then rotates.

Immediately the motor rotates the 'Park on screen' switch is set to the Run position and a 12 volts positive supply is fed via the Run position to maintain 12 volts positive at the coil of relay 1.

After one wipe cycle the wiper motor sets the 'Park on screen' switch to the Park position, thus de-energising relay 1 and disconnecting the motor supply. The motor stops with the screen wiper blades in the Park on screen position.

After a delay of approximately seven seconds the electronic control unit of the system again sets a momentary 12 volts positive supply at terminal 2, causing the cycle to be repeated.

The intermittent wipe cycle continues until the windscreen wiper control switch is set to the OFF position.

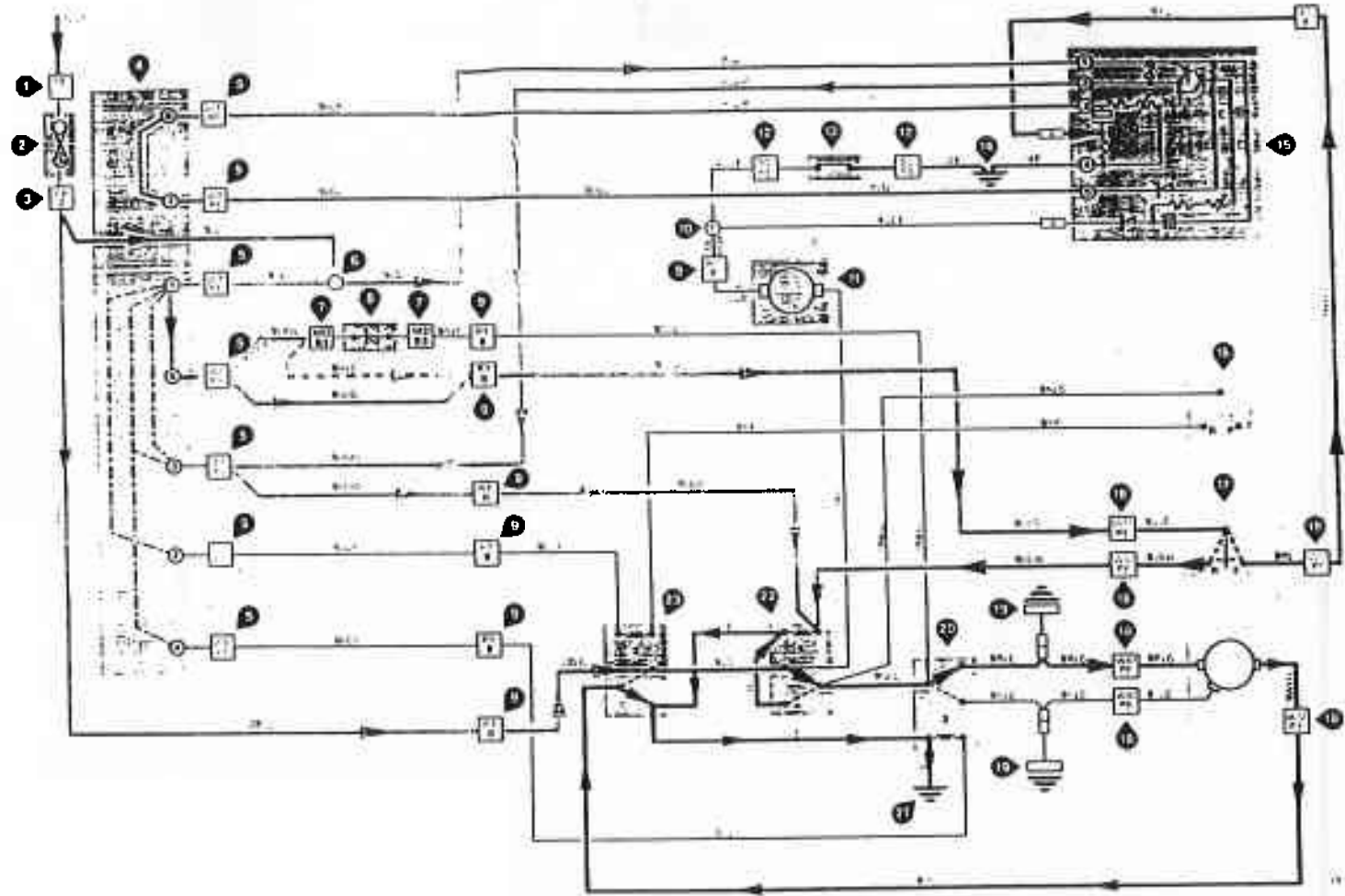

## Windscreen wipers and washers

Wash/Wipe mode

Wiring diagram and circuit description

**Circuit description**

**Wash/wipe mode**  
With the ignition switch in the RUN or ACC position the screen washer pump receives a 12 volts positive supply from fuse 5 at the fuseboard. Depressing the wash/wipe switch on the steering column provides an earth path for the pump which then operates.

The wash/wipe switch also provides an earth path via splice connection 5 for the light green/black flying lead of the wiper system electronic control unit. This provides a 12 volts positive supply at terminal 2 of the control unit, energising relay 1 and thereby allowing 12 volts positive through the normally open contacts of relay 1, and through the normally closed contacts of relay 3, to the slow speed brush of the wiper motor. This supply is routed from fuse 5 at the fuseboard via lothead plug B and also the connection at relay 2 socket. The earth path for the wiper motor is directed through the normally closed contacts of relay 2 and the connection at relay 3 socket to the vehicle earth point.

On releasing the wash/wipe switch the screen wash pump stops immediately, but the wiper system control unit maintains the 12 volts positive supply at terminal 2 for a further five seconds causing the wiper motor to complete approximately five cycles. The wipe cycle ends with the wiper blades in the parked position details of which are shown in the diagrams for the Off position.

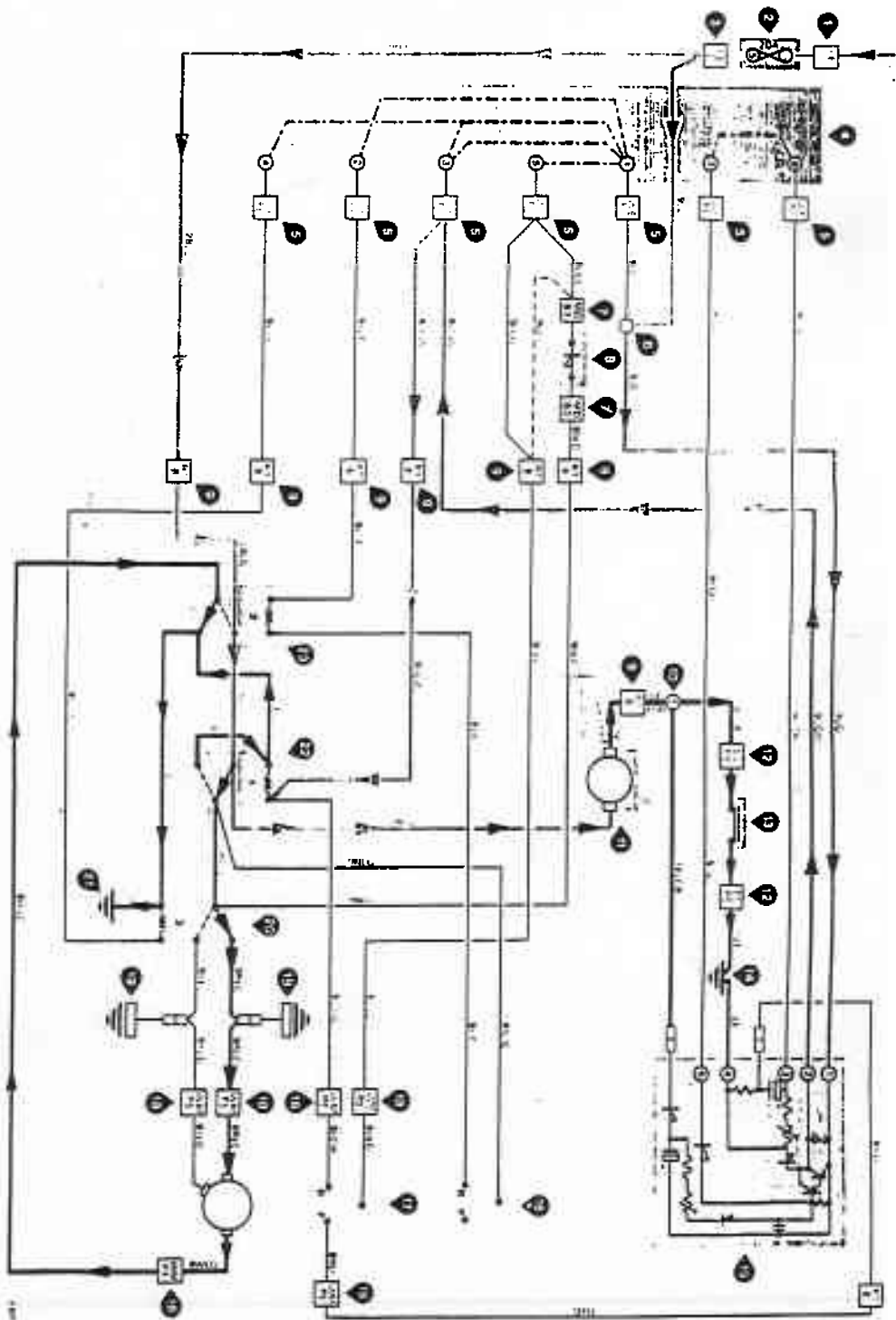

# Windscreen wipers and washers

Component location

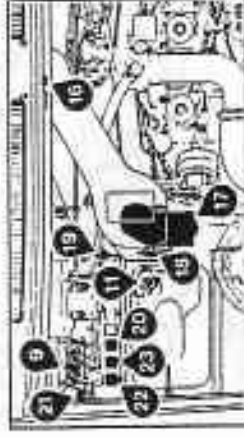
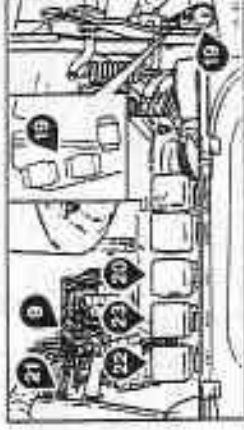
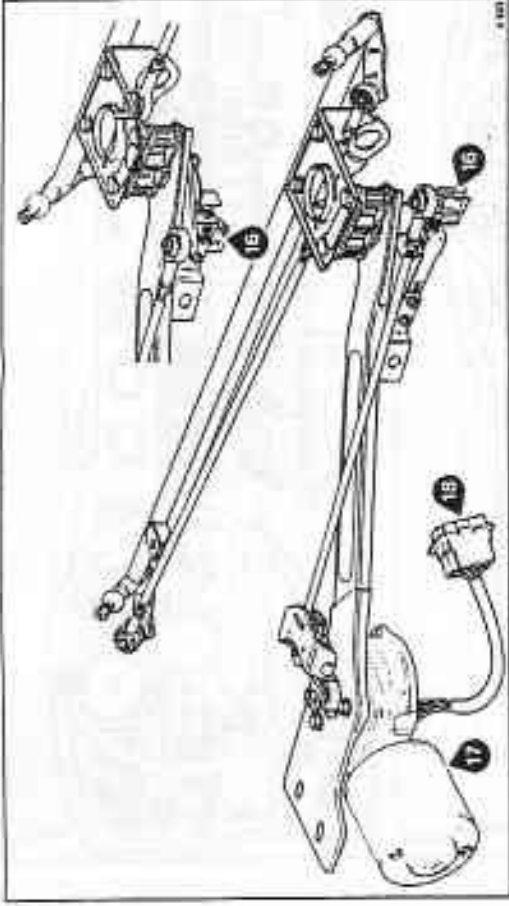

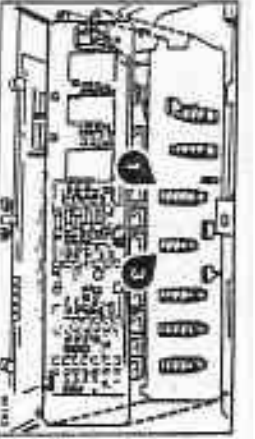
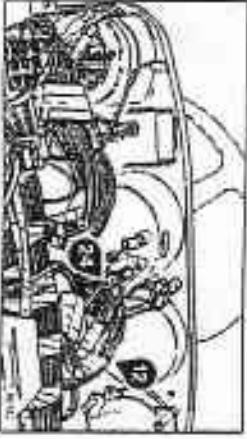
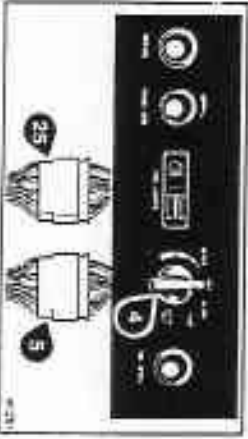
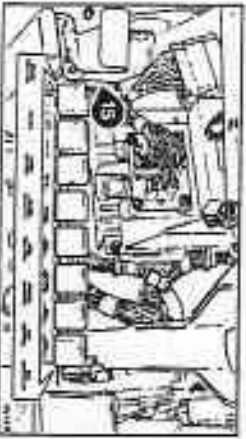
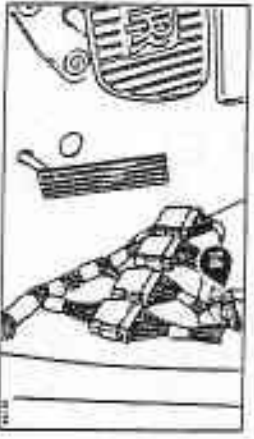
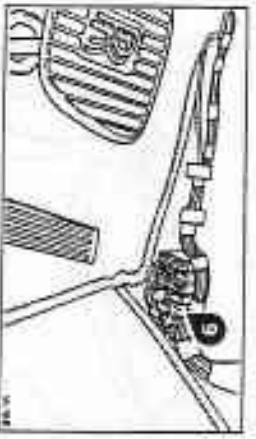
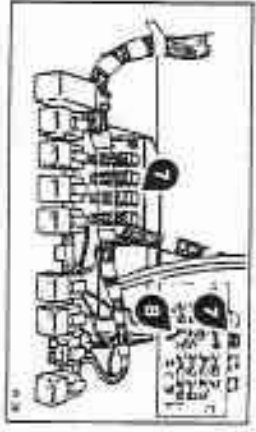
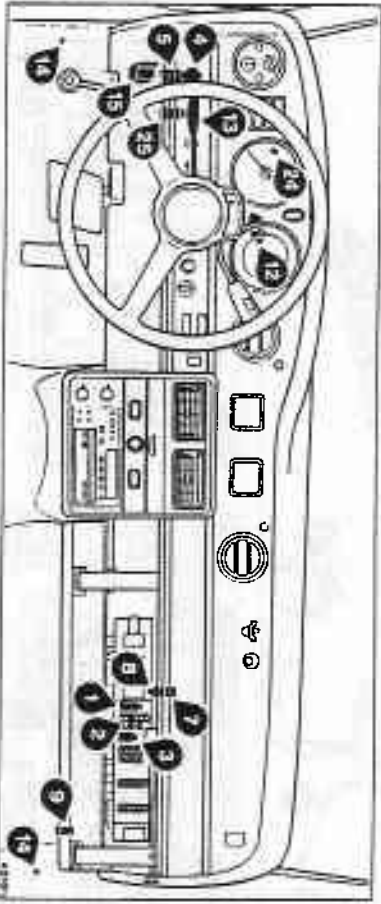
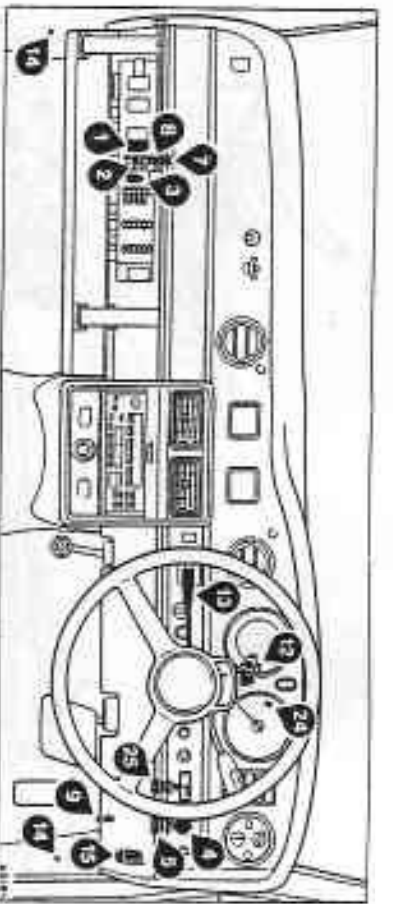

Callout	Component	Location
1	Front Passenger Side	Front Passenger Side
2	Front Driver's Side	Front Driver's Side
3	Rearview Mirror	Front Passenger Side
4	Center Console	Front Passenger Side
5	Front Passenger Seat	Front Passenger Side
6	Front Driver's Seat	Front Driver's Side
7	Upper Dashboard	Front Passenger Side
8	Center Console	Front Passenger Side
9	Front Passenger Seat	Front Passenger Side
10	Rear Trunk Area	Rear Trunk Area
11	Upper Dashboard	Front Driver's Side
12	Center Console	Front Driver's Side
13	Front Driver's Seat	Front Driver's Side
14	Upper Dashboard	Front Driver's Side
15	Rear Driver's Side	Rear Driver's Side

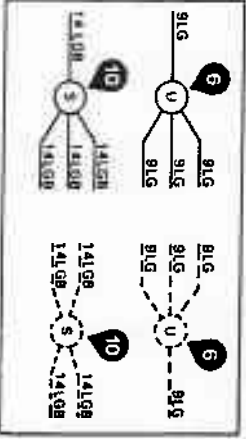

## **Windscreen wipers and washers**

**INTER (Intermittent) positions**

**Wiring diagram and circuit description**



# Windscreen wipers and washers

Corniche/Continental

Component location

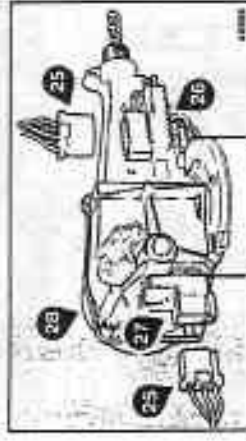
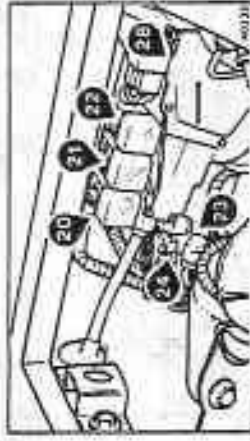
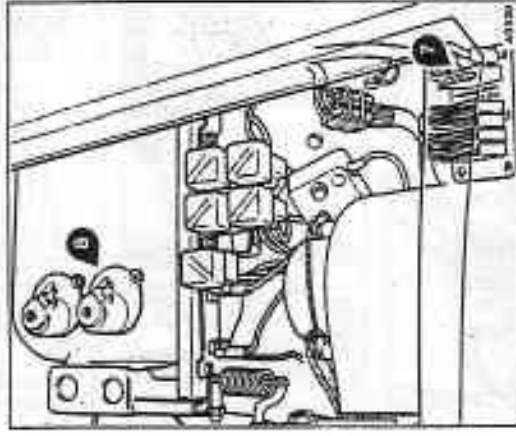
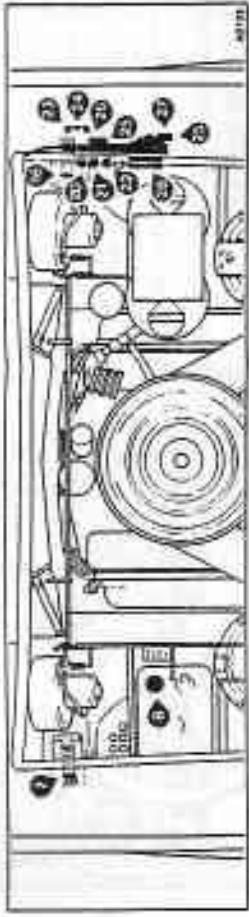

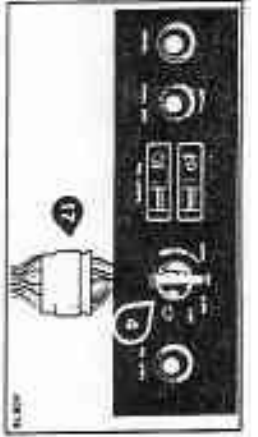
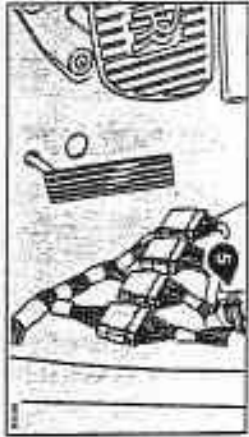
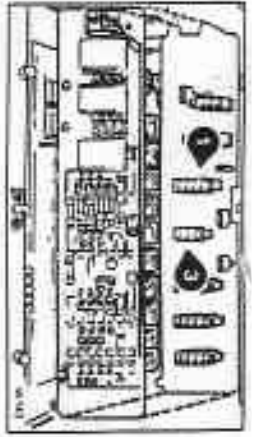
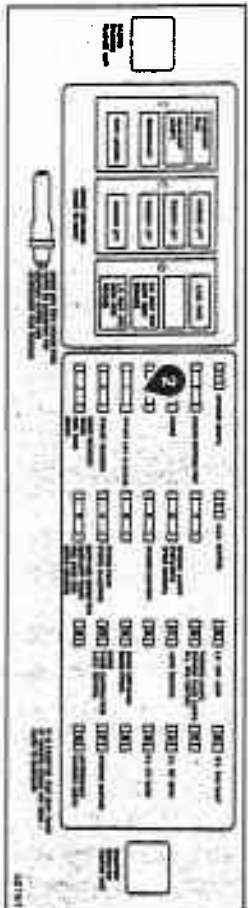
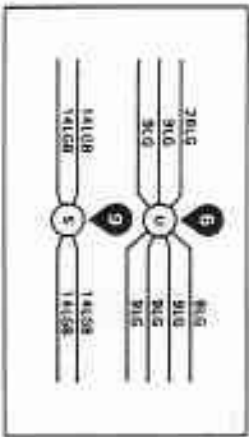
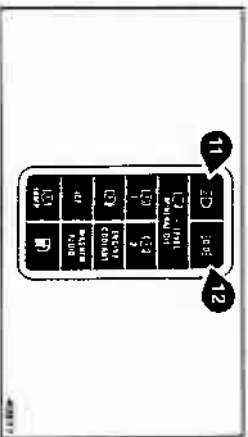
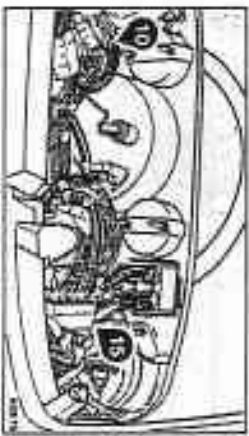
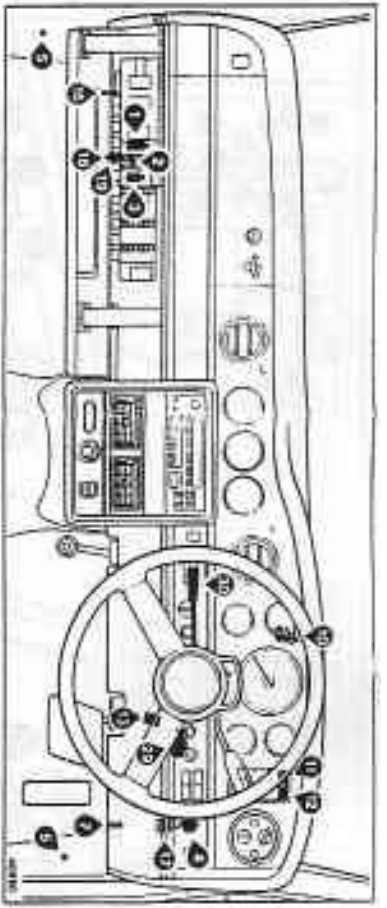
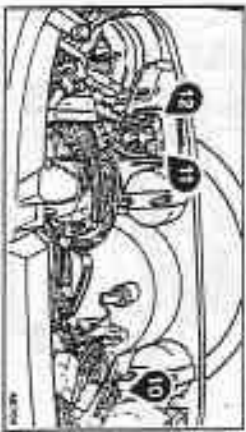
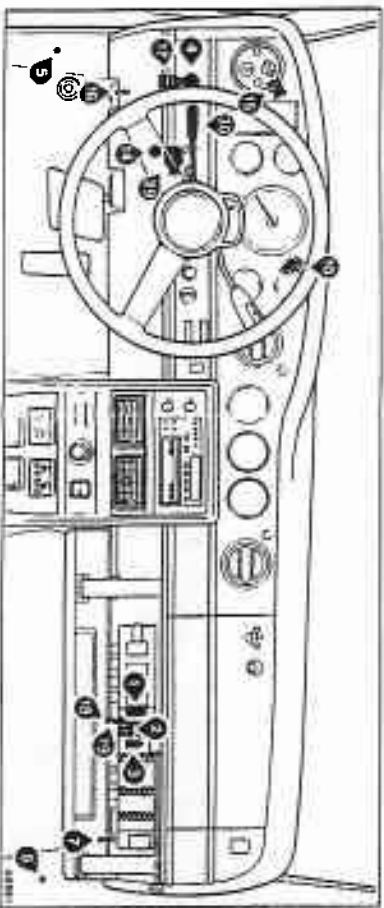

## **Windscreen wipers and washers**

Corniche/Continental

OFF position 1

Wiring diagram and circuit description

### Circuit description

With the windscreen wiper control switch in the OFF position, switch contacts 1 and 2 are closed. If the screen wiper system is operating and OFF position is then selected the wiper motor continues to rotate until the motor acts the Park on screen switch (within the motor assembly) to the Park position. This breaks the 12 volt positive supply to the coil of relay 1, thereby de-energizing the relay and removing the 12 volt positive supply from the slow speed brush of the wiper motor. This supply to the motor is routed from fuse 5 at the fuseboard via right-hand lapboard plug B and also the connection at relay 2 socket.

The slow speed brush of the wiper motor now finds an earth path through the normally closed contacts of relays 3 and 1 and via connections at relay sockets 1, 2, and 3 to the vehicle earth point.

The coil of relay 2 (receiving 12 volt positive from wiper switch contact 2) finds an earth path via the Run position of the Park off screen switch, thereby energizing relay 2. This provides a 12 volt positive supply through the normally open contacts to the wiper motor. The motor reverses direction, causing the Park off screen switch to be set to the Park position. This disconnects the earth path causing the motor to stop with the windscreen wiper blades in the parked position.

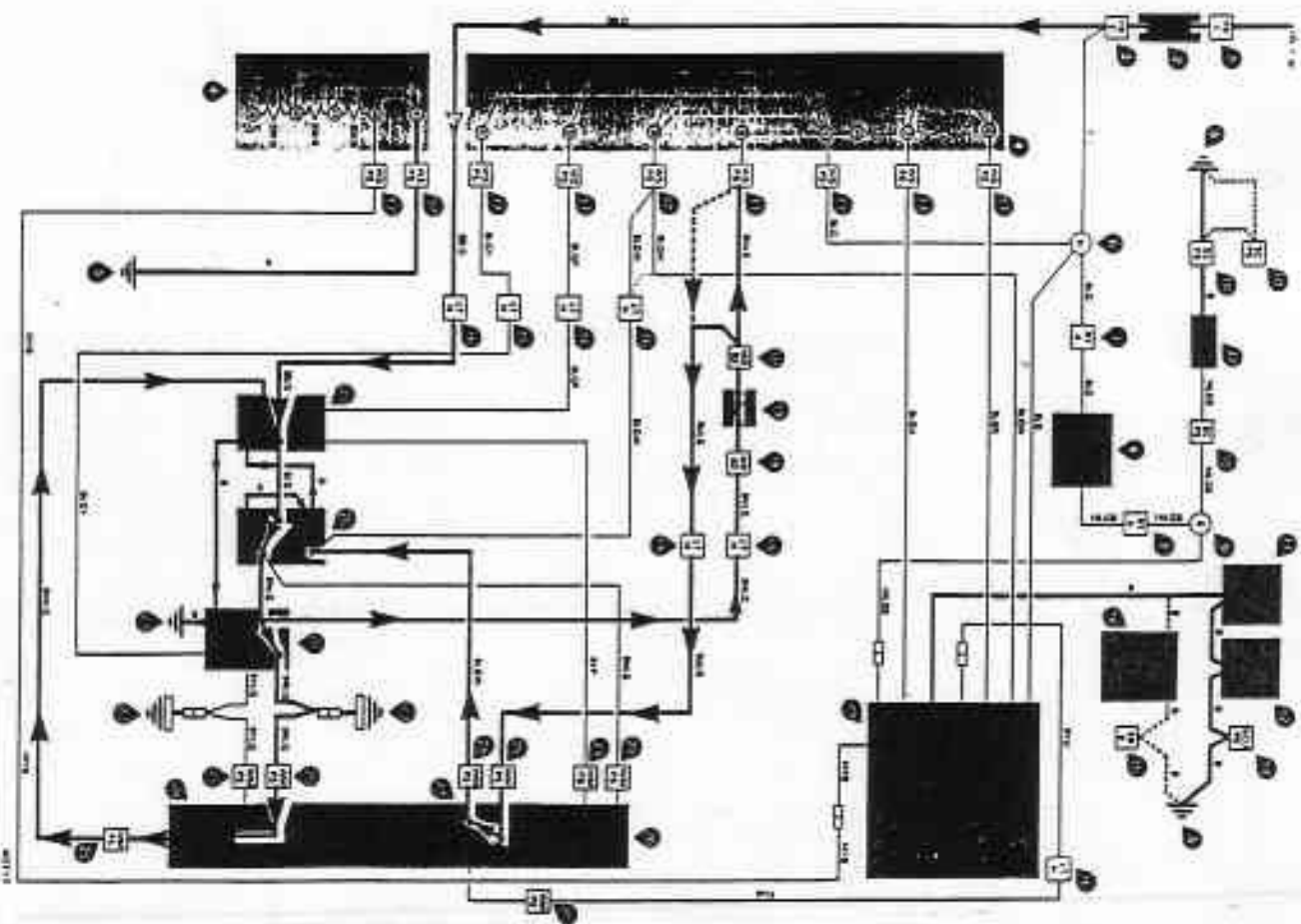

## **Windscreen wipers and washers**

Corniche/Continental

OFF position 1

Wiring diagram and circuit description

2 position  
 of the windshield wiper control switch in the OFF  
 position, switch contacts 1 and 2 are closed. If the  
 wiper system is operating and OFF position is  
 selected the wiper motor continues to rotate until  
 motor sets the Park on screen switch within the  
 motor assembly to the Park position. This breaks the  
 12 volt positive supply to the coil of relay 1, thereby  
 energizing the relay and removing the 12 volts  
 drive supply from the slow speed brush of the  
 wiper motor. This supply to the motor is routed from  
 wiper motor to the baseboard via right-hand foreboard plug B  
 5 into the connection at relay 2 socket.

The slow speed brush of the wiper motor now  
 draws an earth path through the normally closed  
 contacts of relays 3 and 1, and via connections at relay  
 sockets 1, 2, and 3 to the valence earth point.

The coil of relay 2 (receiving 12 volts positive from  
 wiper switch contact 2) finds an earth path via the Run  
 position of the Park off screen switch, thereby  
 energizing relay 2. This provides a 12 volt positive  
 supply through the normally open contacts to the  
 wiper motor. The motor reverses direction, causing the  
 Park off screen switch to be set to the Park position.  
 This disconnects the earth path causing the motor to  
 stop with the windshield wiper blades in the parked  
 position.

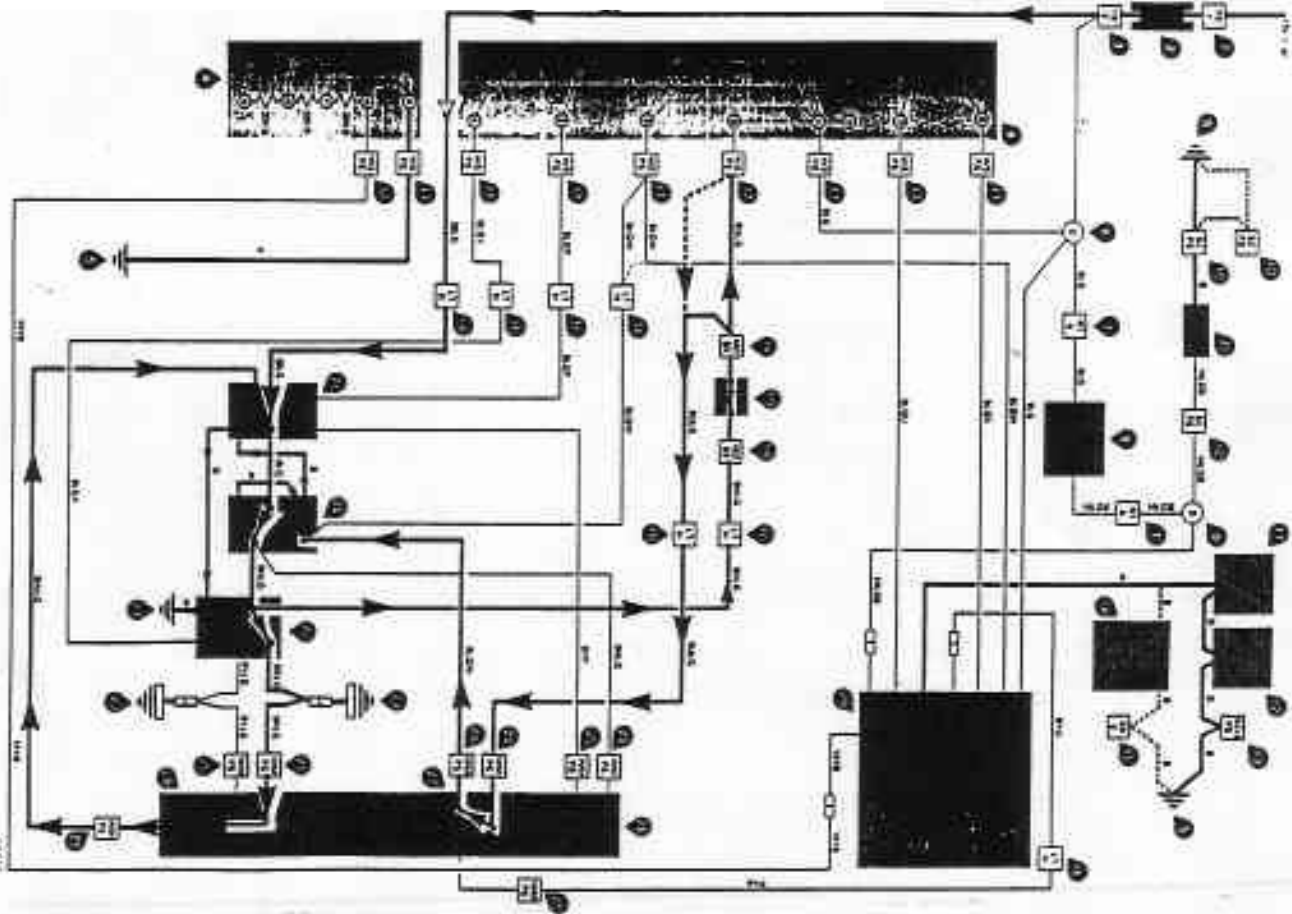

## **Windscreen wipers and washers**

**Corniche/Continental**

**OFF position 2**

**Wiring diagram and circuit description**

**Circuit description**

**OFF position**  
 With the windscreen wiper control switch in the OFF position, switch contacts 1 and 2 are closed at the screen wiper system. Operating and OFF position is then selected the wiper motor continues to rotate until the motor sets the Park on screen switch within the 12 volts positive supply to the coil of relay 1, thereby de-energizing the relay and removing the 12 volts positive supply. This supply to the motor is routed from fuse 5 at the fuseboard via right-hand looboard plug B and also the connection at relay 2 socket.

The slow speed brush of the wiper motor now finds an earth path through the normally closed contacts of relays 3 and 1, and via connections at relay sockets 1, 2, and 3 to the valance earth point.

The coil of relay 2, receiving 12 volts positive from wiper switch contact 2, finds an earth path via the Run position of the Park off screen switch, thereby energizing relay 2. This provides a 12 volts positive supply through the normally open contacts to the wiper motor. The motor (reverses direction, causing the Park off screen switch to be set to the Park position. This disconnects the earth path causing the motor to stop with the windscreen wiper blades in the parked position.

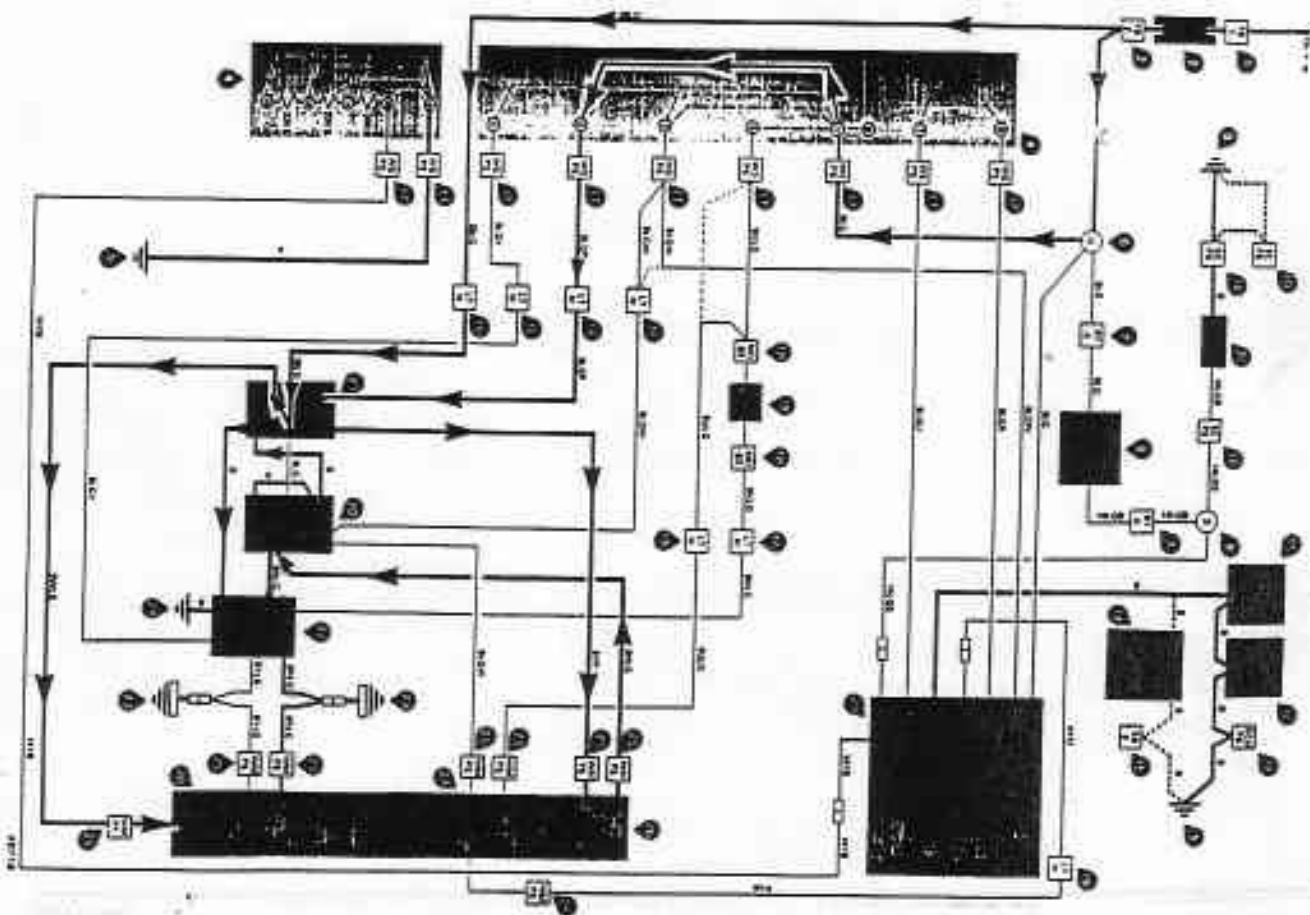

# Headlamps power wash

Component location

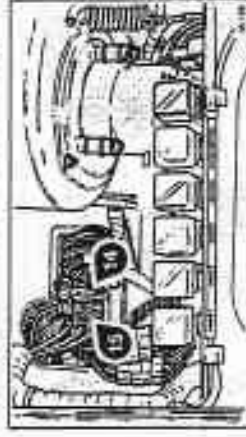
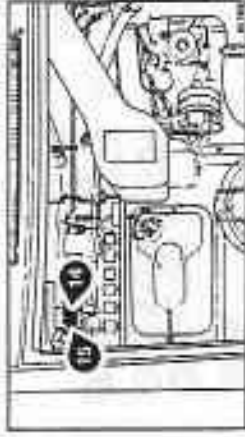
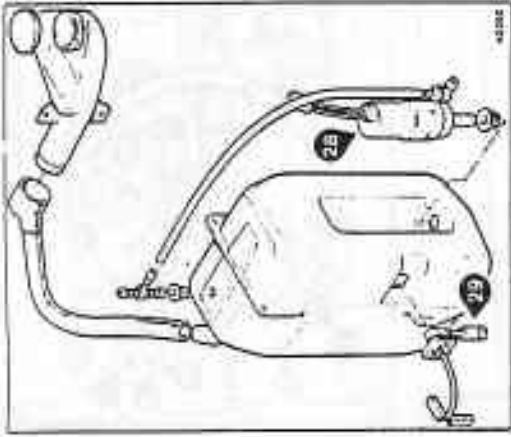



## Headlamp wipers and washers

Contents	Pages			
	Silver Spirit Mulsanne	Silver Spur	Mulsanne Turbo	Corniche
Wiring diagram and component location	M12-1	M12-1	—	—

## Headlamp wipers and washers

Contents	Pages					
	Silver Spirit Mulsanne	Silver Spur	Mulsanne Turbo	Bentley Eight	Bentley Turbo R	Corniche/ Continental
Component location	M12-3	M12-3	—	—	—	M12-7
Wiring diagram	M12-5	M12-5	—	—	—	M12-9

From VIN \*SCAZS0006GCX13860\* (excluding Corniche/Continental) and with the exception of VIN \*SCAZN0004FCH14000\* to VIN \*SCAZN0009FCH14025\* inclusive, a new type of fuseboard is fitted incorporating Littell or Buss fuses (these fuses are not interchangeable with Bulgin type fuses).

Therefore when working to a wiring diagram or component location showing the earlier Bulgin type of fuse, reference must be made to the following table for its equivalent.

Circuits controlled	Bulgin fuse number	Littell or Buss fuse number and fuseboard identification	Fuse rating (amps)	Circuits controlled	Bulgin fuse number	Littell or Buss fuse number and fuseboard identification	Fuse rating (amps)
Cellular telephone when fitted	—	A1 - F2	4A	Rear window demister and mirror heaters	11	B4 - F3	20A
Cellular telephone when fitted	—	A2 - F2	10A	Reverse lamps, stoplamps, speed control, headlamp wash	10	B3 - F3	20A
Interior lamps	1	A6 - F2	10A	Direction indicators, headlamp flash, fuel door, horns control	14	B2 - F3	20A
Radio, panel illumination, ACU control	20	B1 - F2	10A	Cigar lighters, clock, aerial, fuel door	7	C4 - F3	20A
Radio amplifier when fitted	19	B2 - F2	10A	Engine cooling fan	2	C1 - F3	20A
Starter, ignition, fuel pump	27	B3 - F2	10A	Engine cooling fan	9	C1 - F3	20A
Instruments and warning lamps	28	B4 - F2	10A	Wipers and washers	5	B1 - F3	20A
ACU control	8	B5 - F2	10A	Spare	—	B6 - F3	20A
Spare	—	B6 - F2	10A	Fuel pump	13	B5 - F3	20A
L.H. Tail lamp	15	C1 - F2	10A	Horns	3	C3 - F3	20A
R.H. Tail lamp	22	C2 - F2	10A	Fog lamps when fitted	12	C6 - F3	20A
Parking lamps, number plate lamps, W.L. dim. control	16	C3 - F2	10A	Air horns when fitted	4	C5 - F3	20A
L.H. Dip beam	24	C4 - F2	10A	Hazard warning	6	C2 - F3	20A
R.H. Dip beam	25	C5 - F2	10A				
Spare	—	C6 - F2	10A				
Spare	—	A6 - F3	20A				

For fuse identification refer to Section M1, General information, page M1-3.

## Headlamp wipers and washers

Component location

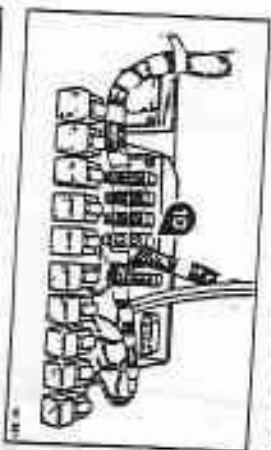
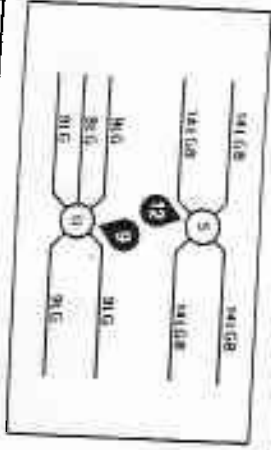
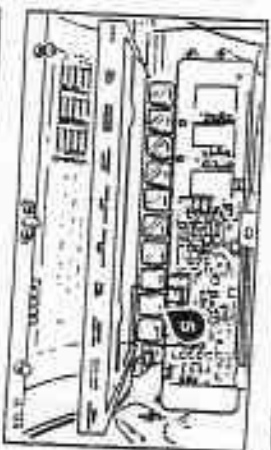
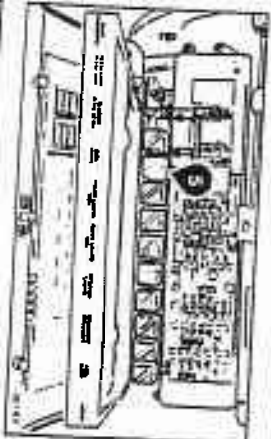
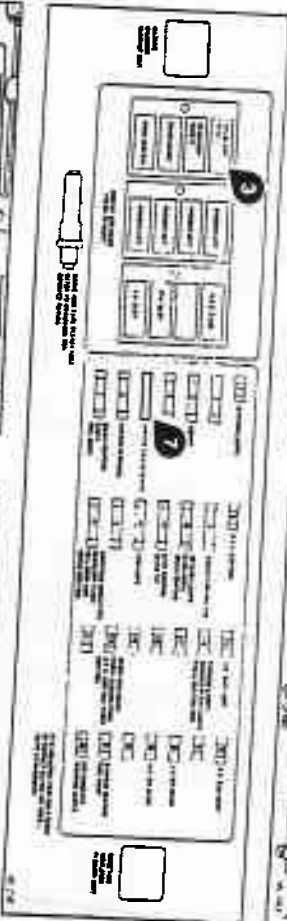
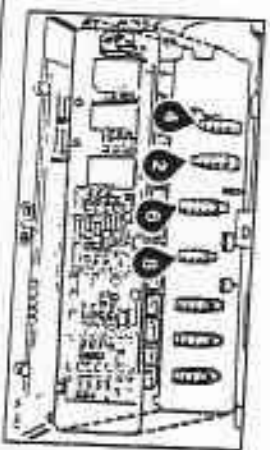
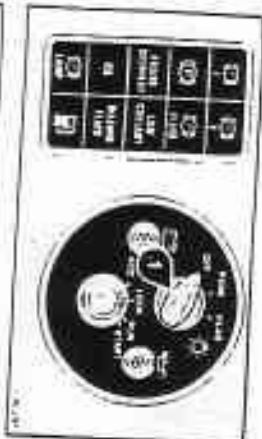
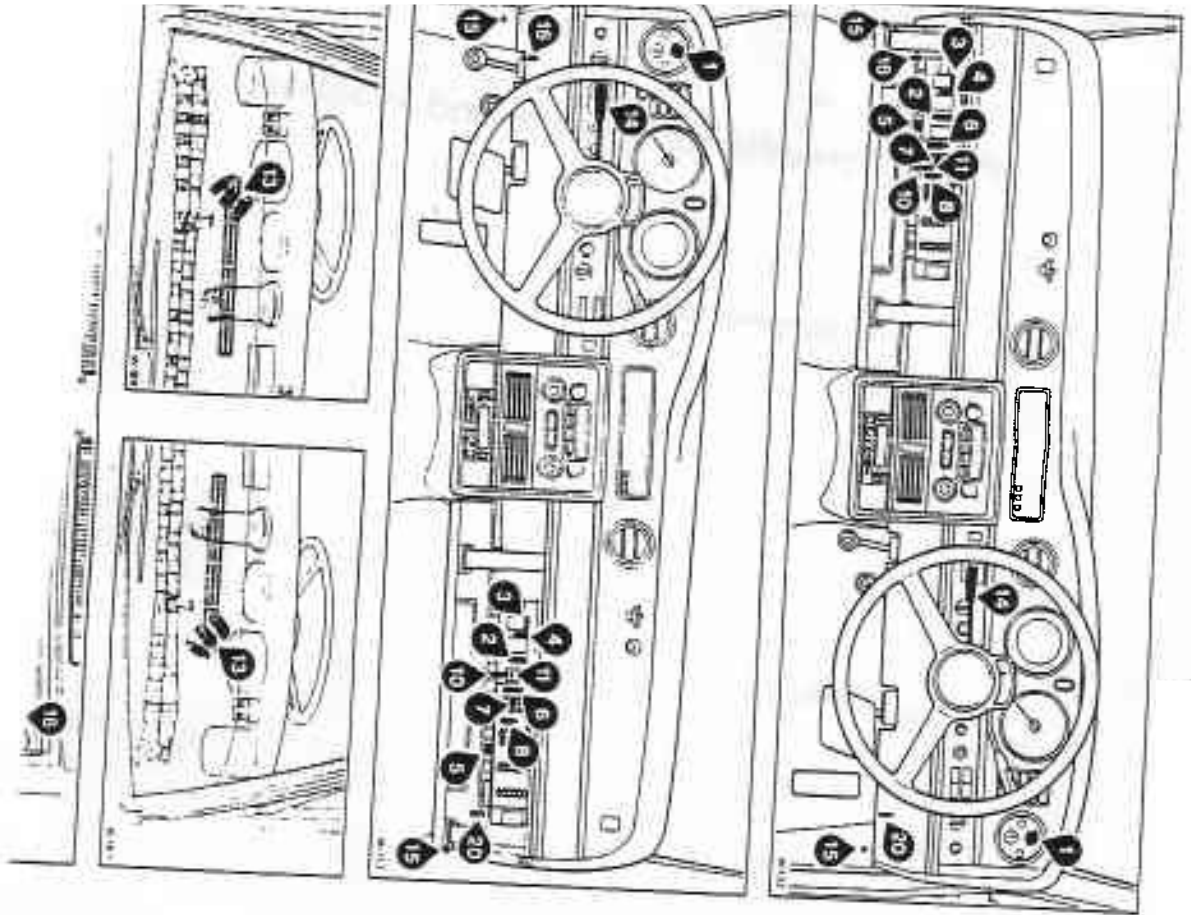

## Headlamp wipers and washers

Wiring diagram



# **Headlamps wipers and washers**

## **Corniche/Continental**

Component location

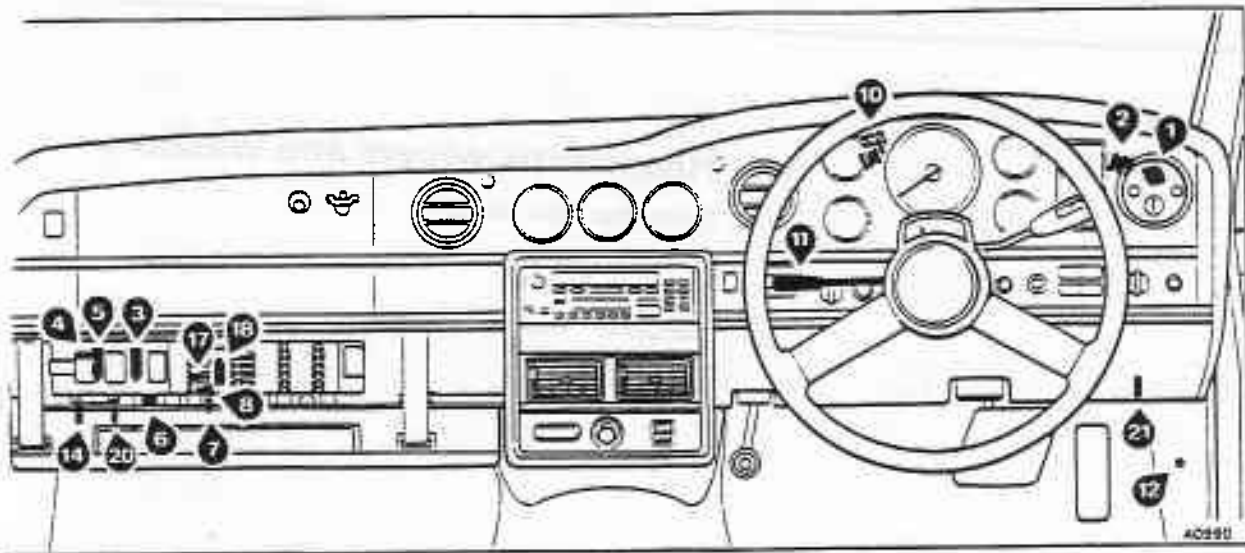

40680

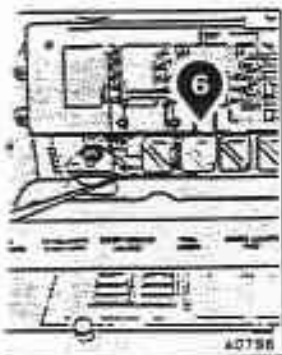

A0756



40684

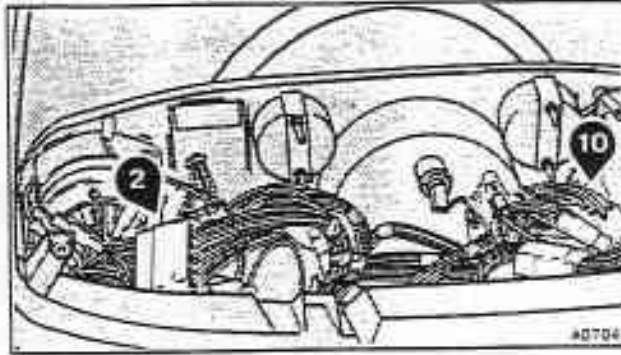

A0704

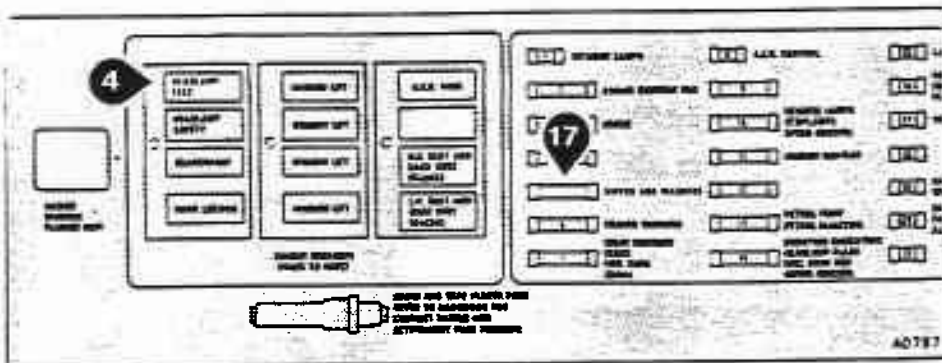

A0787

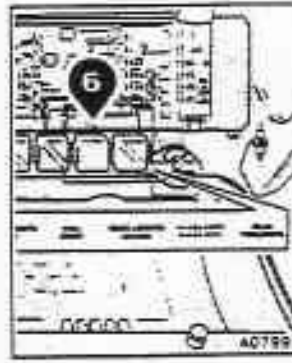

A0799

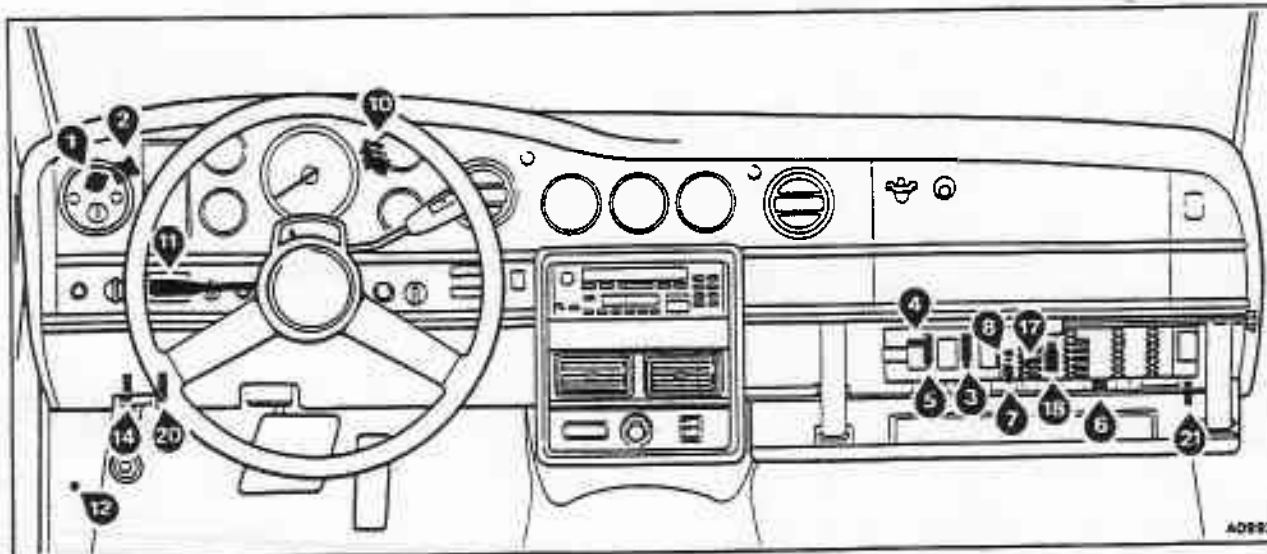

A0692

## **Headlamps wipers and washers**

**Corniche/Continental**

**Wiring diagram**

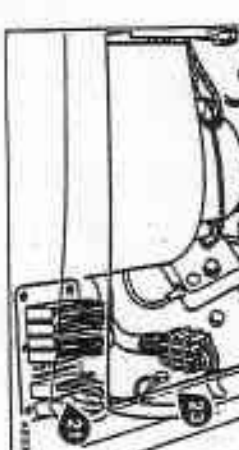
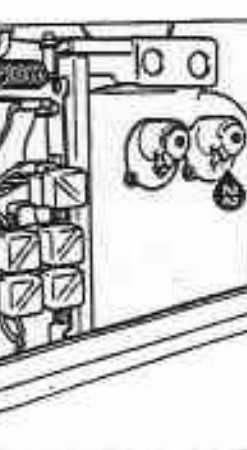
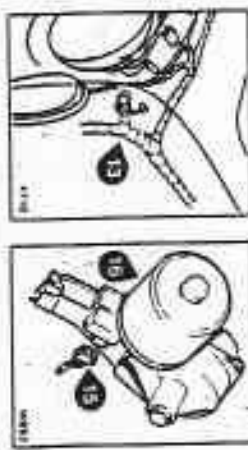
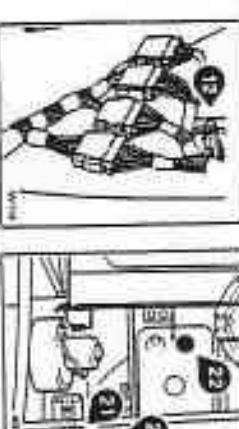
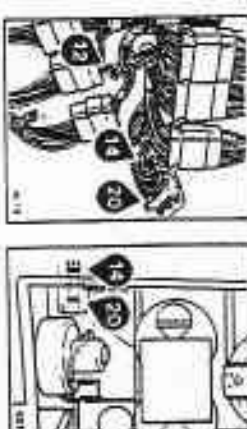
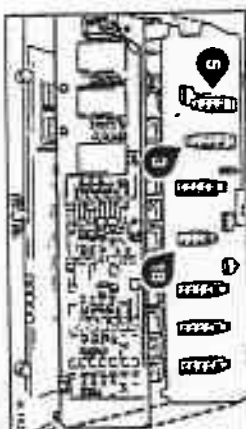
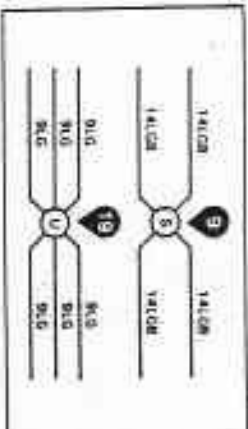
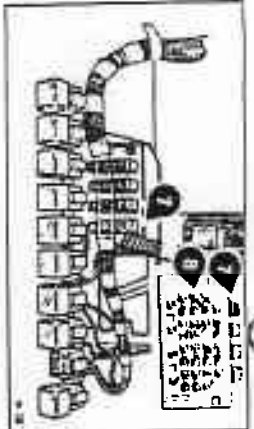
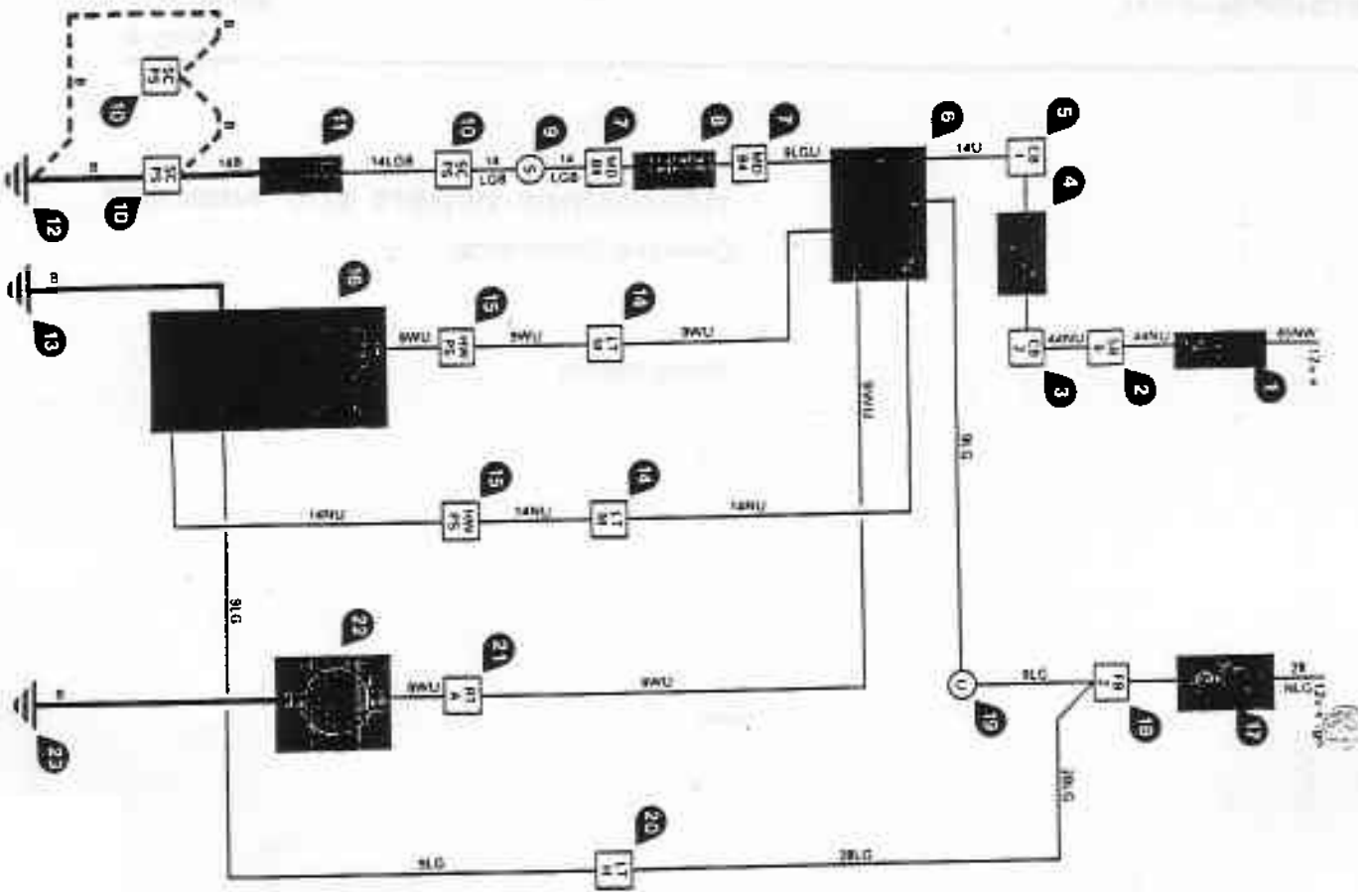





## Direction indicators and Hazard warning system

Contents	Pages					
	Silver Spirit Mulsanne	Silver Spur	Mulsanne Turbo	Bentley Eight	Bentley Turbo R	Corniche/ Continental
Component location	M13-3	M13-3	M13-3	M13-3	M13-3	M13-3
Wiring diagram	M13-5	M13-5	M13-5	M13-5	M13-5	M13-7

From VIN \*SCAZS0006GCX13860\* (excluding Corniche/Continental) and with the exception of VIN \*SCAZN0004FCH14000\* to VIN \*SCAZN0009FCH14025\* inclusive, a new type of fuseboard is fitted incorporating Littell or Buss fuses (these fuses are not interchangeable with Bulgin type fuses).

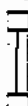
Therefore when working to a wiring diagram or component location showing the earlier Bulgin type of fuse, reference must be made to the following table for its equivalent.

Circuits controlled	Bulgin fuse number 	Littell or Buss fuse number and fuseboard identification 	Fuse rating (amps)	Circuits controlled	Bulgin fuse number 	Littell or Buss fuse number and fuseboard identification 	Fuse rating (amps)
Cellular telephone when fitted	—	A1 - F2	4A	Rear window demister and mirror heaters	11	B4 - F3	20A
Cellular telephone when fitted	—	A2 - F2	10A	Reverse lamps, stoplamps, speed control, headlamp wash	10	B3 - F3	20A
Interior lamps	1	A6 - F2	10A	Direction indicators, headlamp flash, fuel door, horns control	14	B2 - F3	20A
Radio, panel illumination, ACU control	20	B1 - F2	10A	Cigar lighters, clock, aerial, fuel door	7	C4 - F3	20A
Radio amplifier when fitted	19	B2 - F2	10A	Engine cooling fan	2	C1 - F3	20A
Starter, ignition, fuel pump	27	B3 - F2	10A	Engine cooling fan	9	C1 - F3	20A
Instruments and warning lamps	28	B4 - F2	10A	Wipers and washers	5	B1 - F3	20A
ACU control	8	B5 - F2	10A	Spare	—	B6 - F3	20A
Spare	—	B6 - F2	10A	Fuel pump	13	B5 - F3	20A
L.H. Tail lamp	15	C1 - F2	10A	Horns	3	C3 - F3	20A
R.H. Tail lamp	22	C2 - F2	10A	Fog lamps when fitted	12	C6 - F3	20A
Parking lamps, number plate lamps, W.L dim control	16	C3 - F2	10A	Air horns when fitted	4	C5 - F3	20A
L.H. Dip beam	24	C4 - F2	10A	Hazard warning	6	C2 - F3	20A
R.H. Dip beam	25	C5 - F2	10A				
Spare	—	C6 - F2	10A				
Spare	—	A6 - F3	20A				

For fuse identification refer to Section M1, General information, page M1-3.

## Direction indicators and Hazard warning system

Silver Spirit, Silver Spur, Mulsanne  
(including Turbo), and Corniche

Component location

1. Instrument Cluster  
 2. Speedometer  
 3. Tachometer  
 4. Fuel Gauge  
 5. Temperature Gauge  
 6. Oil Pressure Gauge  
 7. Battery Charge Gauge  
 8. Parking Brake Indicator  
 9. ABS Indicator  
 10. Air Filter Indicator  
 11. Brake Pad Indicator  
 12. Tire Pressure Indicator  
 13. Door Ajar Indicator  
 14. Low Fuel Indicator  
 15. Low Oil Indicator  
 16. High Temperature Indicator  
 17. High Voltage Indicator  
 18. ABS Indicator  
 19. Parking Brake Indicator

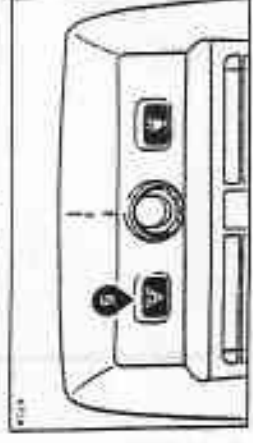
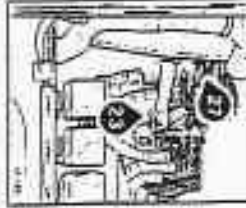
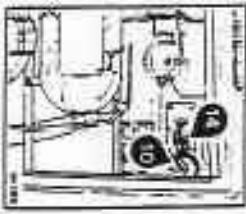
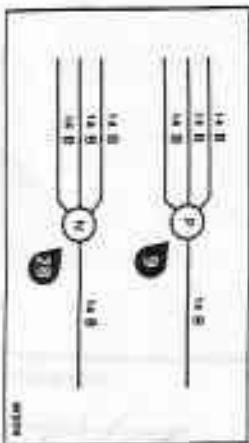
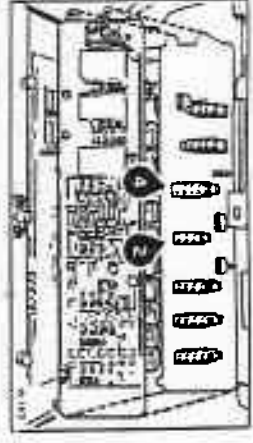
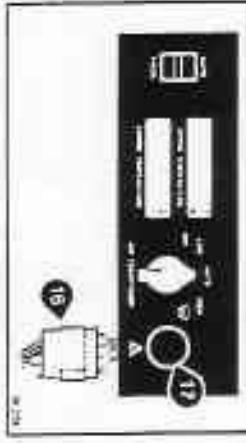
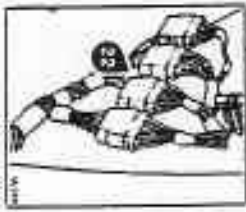
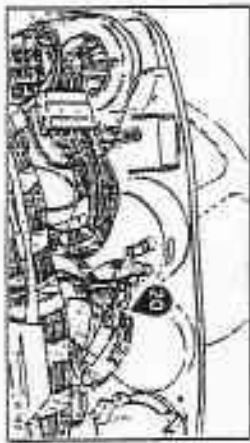
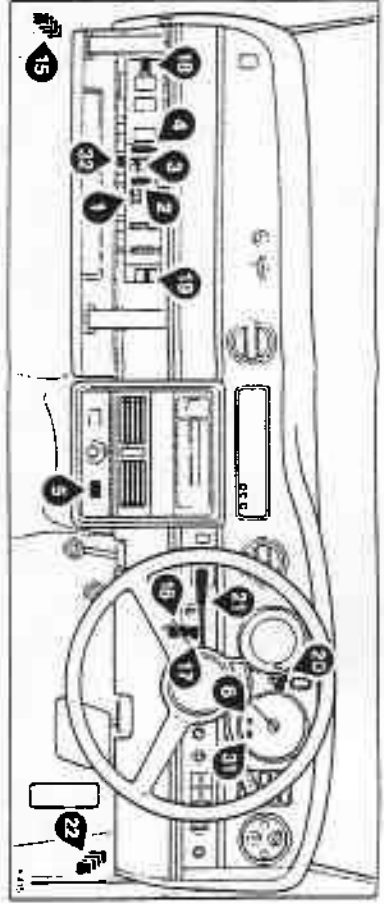
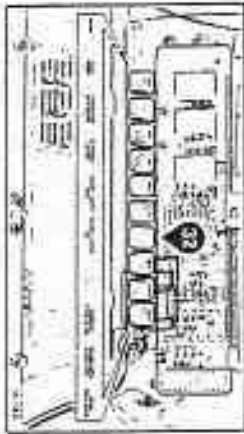
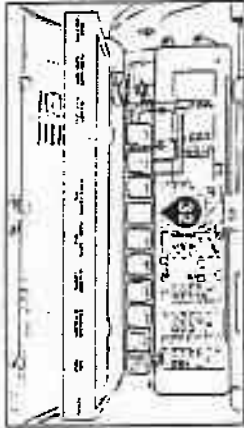
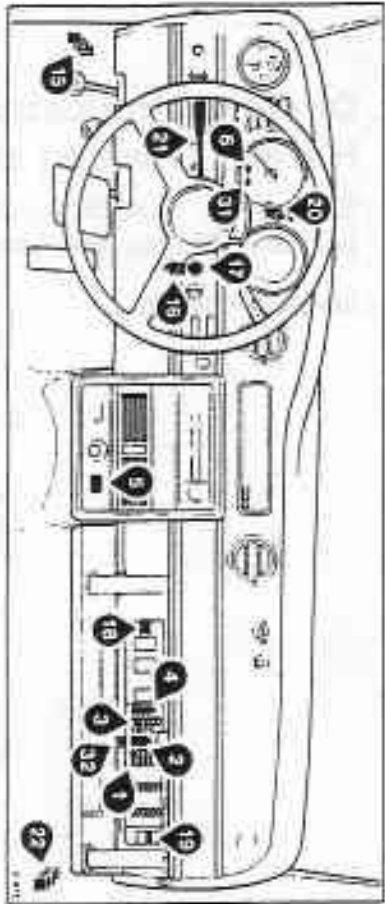

## Direction indicators and Hazard warning system

Silver Spirit, Silver Spur, and Mulsanne  
(including Turbo)

Wiring diagram



**Direction indicators and  
Hazard warning system**

Corniche

Wiring diagram







## Stop, reversing, side/position, and tail lamps

Contents	Pages					
	Silver Spirit Mulsanne	Silver Spur	Mulsanne Turbo	Bentley Eight	Bentley Turbo R	Corniche/ Continental
<b>Stop lamps and reversing lamps</b> Excluding 1986 model year cars <i>conforming to a North American specification</i>						
Component location	M14-3	M14-3	M14-3	M14-3	M14-3	M14-15
Wiring diagram						
Right-hand drive cars	M14-5	M14-5	M14-5	M14-5	M14-5	M14-17
Left-hand drive cars	M14-7	M14-7	M14-7	M14-7	M14-7	M14-17
<b>1986 model year cars</b> <i>conforming to a North American specification</i>						
Component location	M14-7/1	M14-7/1	—	—	—	M14-17/1
Wiring diagram	M14-7/3	M14-7/3	—	—	—	M14-17/3
<b>Side/position and tail lamps</b>						
Component location	M14-9	M14-9	M14-9	M14-9	M14-9	M14-19
Wiring diagram						
Right-hand drive cars	M14-11	M14-11	M14-11	M14-11	M14-11	—
Left-hand drive cars	M14-13	M14-13	M14-13	M14-13	M14-13	—
<b>Corniche cars other than those conforming to a North American specification</b>	—	—	—	—	—	M14-21
<b>Corniche cars conforming to a North American specification</b>	—	—	—	—	—	M14-23

From VIN \*SCAZS0006GCX13860\* (excluding Corniche/Continental) and with the exception of VIN \*SCAZN0004FCH14000\* to VIN \*SCAZN0009FCH14025\* inclusive, a new type of fuseboard is fitted incorporating Littell or Buss fuses (these fuses are not interchangeable with Bulgin type fuses).

Therefore when working to a wiring diagram or component location showing the earlier Bulgin type of fuse, reference must be made to the following table for its equivalent.

Circuits controlled	Bulgin fuse number	Littell or Buss fuse number and fuseboard identification	Fuse rating (amps)	Circuits controlled	Bulgin fuse number	Littell or Buss fuse number and fuseboard identification	Fuse rating (amps)
							
Cellular telephone when fitted	—	A1 - F2	4A	Rear window demister and mirror heaters	11	B4 - F3	20A
Cellular telephone when fitted	—	A2 - F2	10A	Reverse lamps, stoplamps, speed control, headlamp wash	10	B3 - F3	20A
Interior lamps	1	A6 - F2	10A	Direction indicators, headlamp flash, fuel door, horns control	14	B2 - F3	20A
Radio, panel illumination, ACU control	20	B1 - F2	10A	Cigar lighters, clock, aerial, fuel door	7	C4 - F3	20A
Radio amplifier when fitted	19	B2 - F2	10A	Engine cooling fan	2	C1 - F3	20A
Starter, ignition, fuel pump	27	B3 - F2	10A	Engine cooling fan	9	C1 - F3	20A
Instruments and warning lamps	28	B4 - F2	10A	Wipers and washers	5	B1 - F3	20A
ACU control	8	B5 - F2	10A	Spare	—	B6 - F3	20A
Spare	—	B6 - F2	10A	Fuel pump	13	B5 - F3	20A
L.H. Tail lamp	15	C1 - F2	10A	Horns	3	C3 - F3	20A
R.H. Tail lamp	22	C2 - F2	10A	Fog lamps when fitted	12	C6 - F3	20A
Parking lamps, number plate lamps, W.L. dim control	16	C3 - F2	10A	Air horns when fitted	4	C5 - F3	20A
L.H. Dip beam	24	C4 - F2	10A	Hazard warning	6	C2 - F3	20A
R.H. Dip beam	25	C5 - F2	10A				
Spare	—	C6 - F2	10A				
Spare	—	A6 - F3	20A				

For fuse identification refer to Section M1, General information, page M1-3.

## Stop lamps and reversing lamps

Wiring diagram and components location



The stop lamps items 35 and 36 are only fitted on cars conforming to a North American specification.

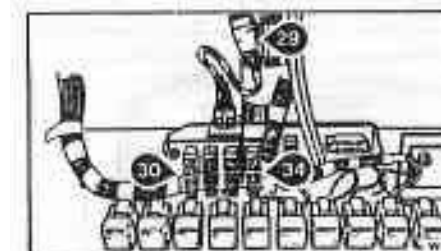
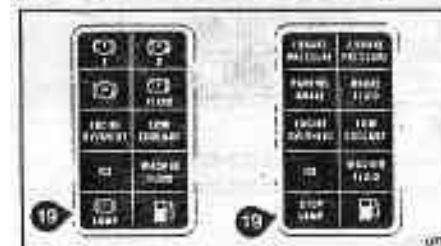
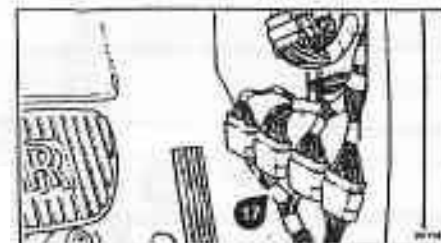



## Stop lamps and reversing lamps

Right-hand drive cars

Wiring diagram and component location

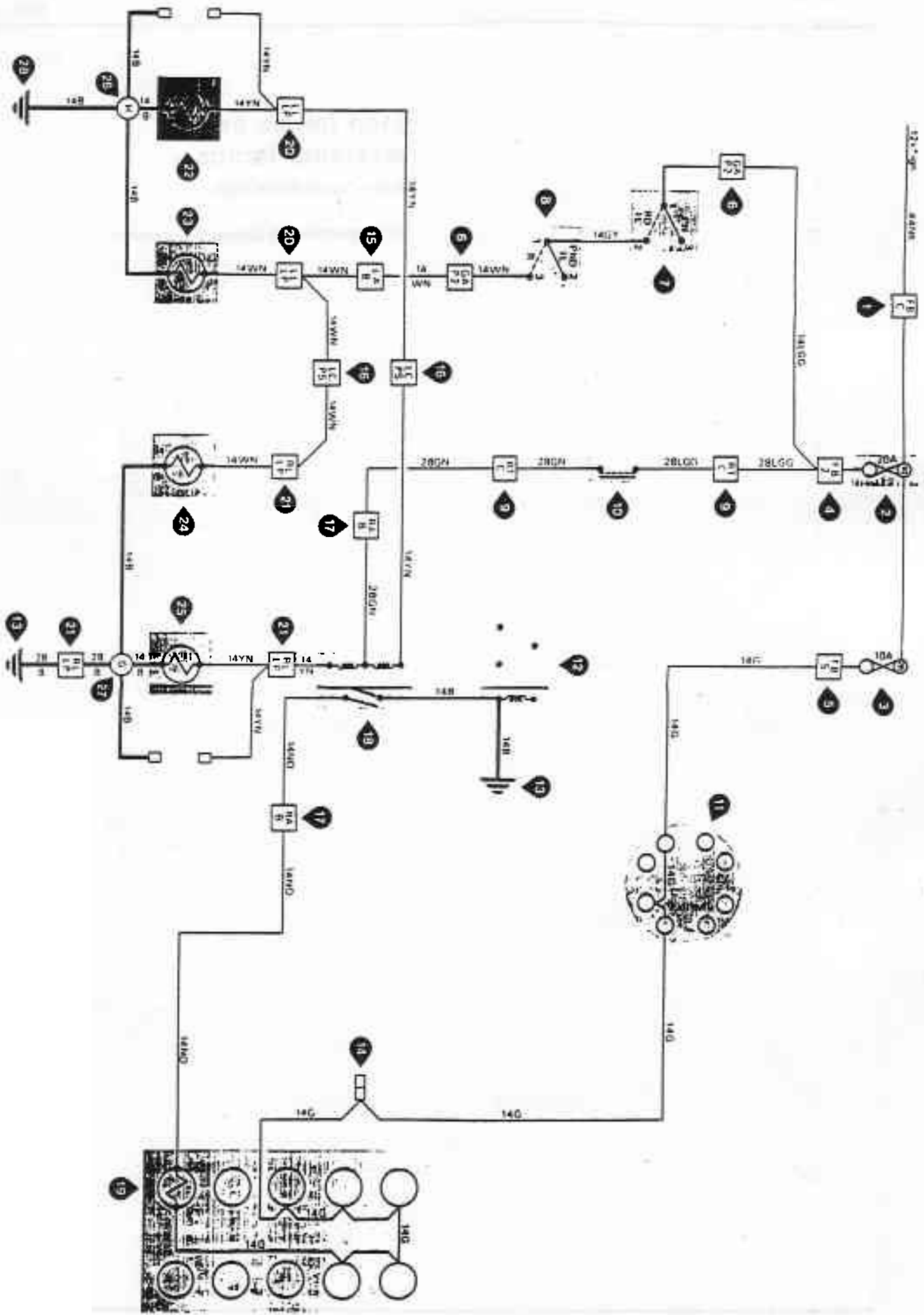

## **Stop lamps and reversing lamps**

Left-hand drive cars

Wiring diagram and component location

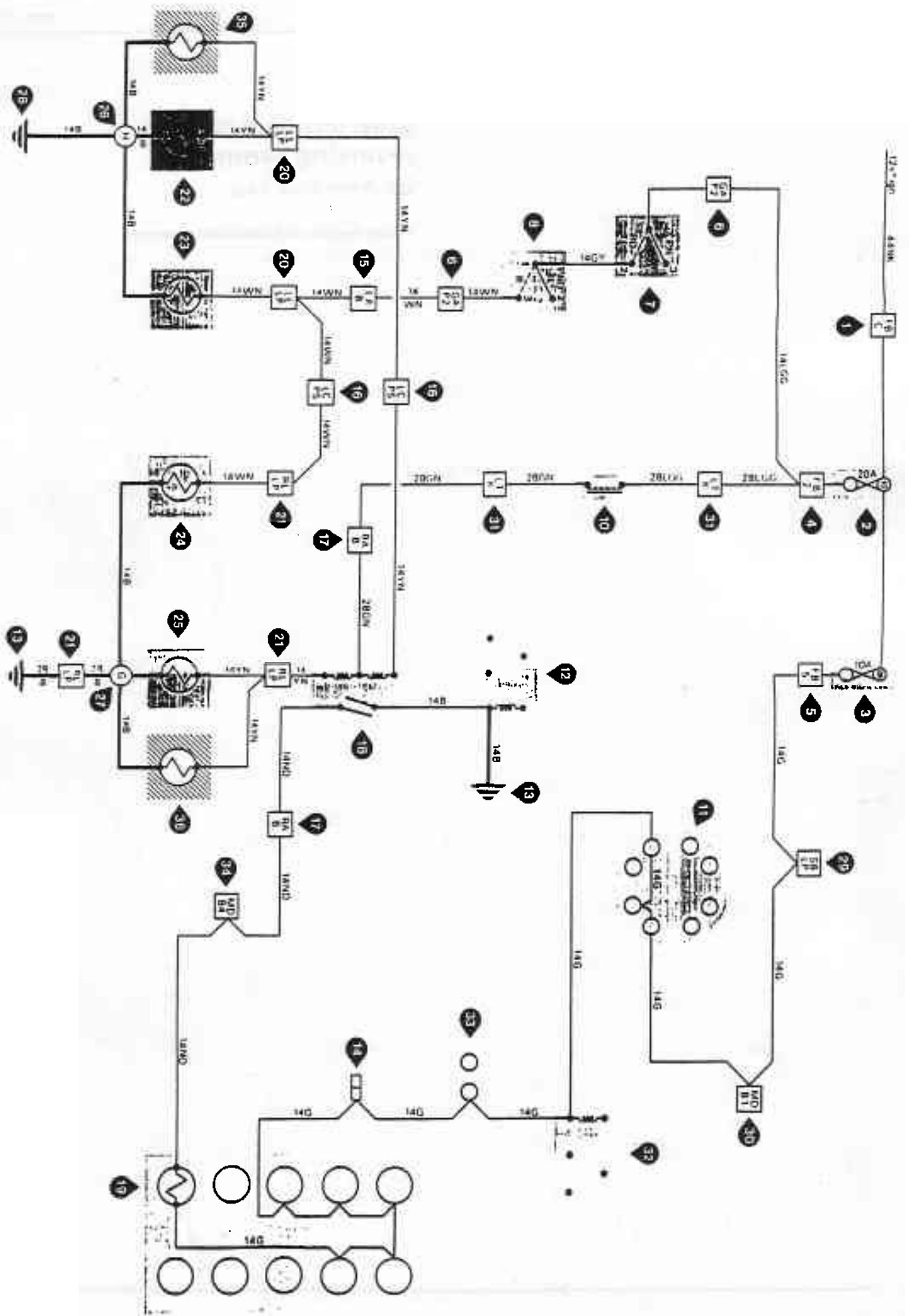

## **Side/position and tail lamps**

Left-hand drive cars

Wiring diagram and component location

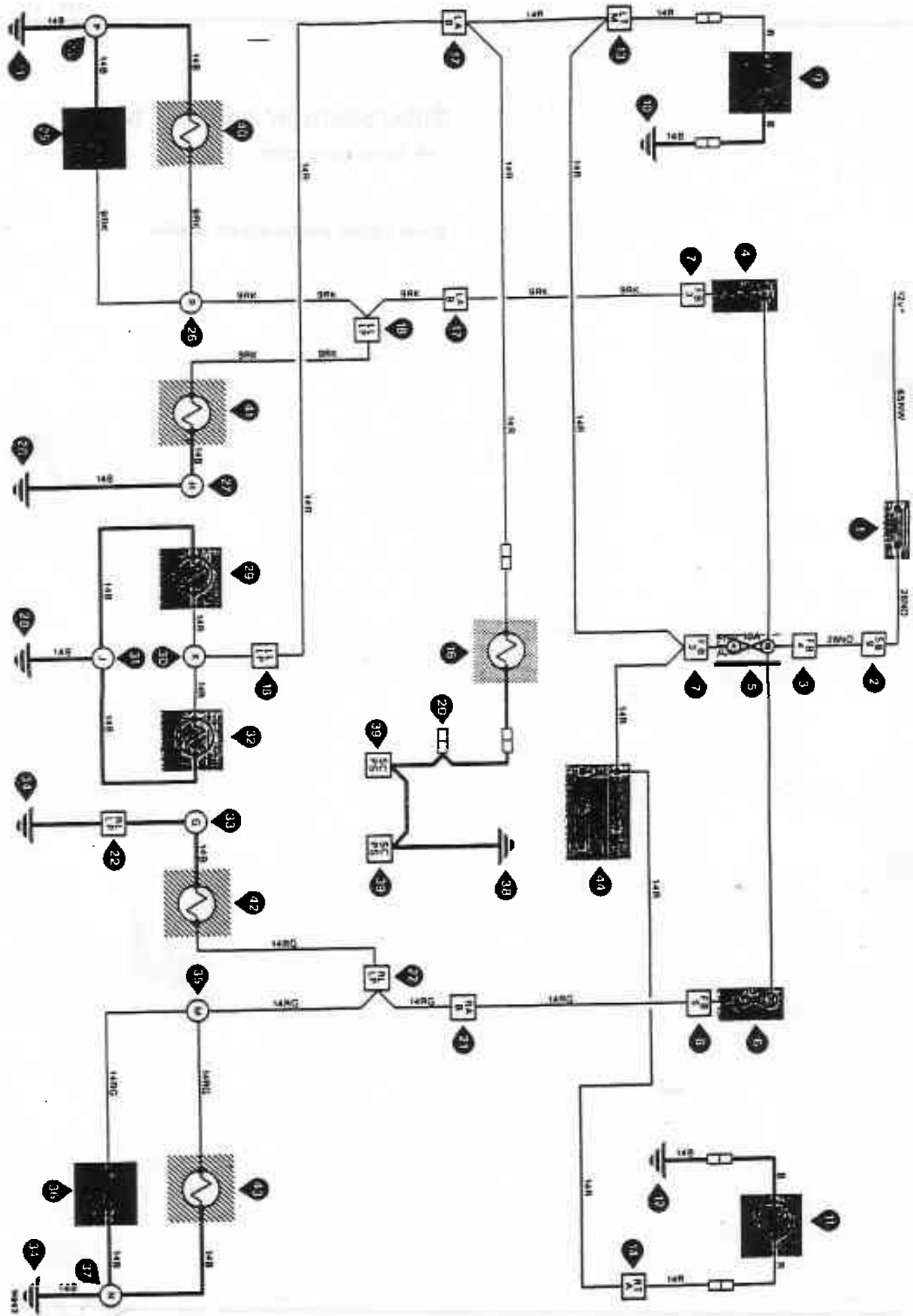

## Stop lamps and reversing lamps

Corniche

Component location

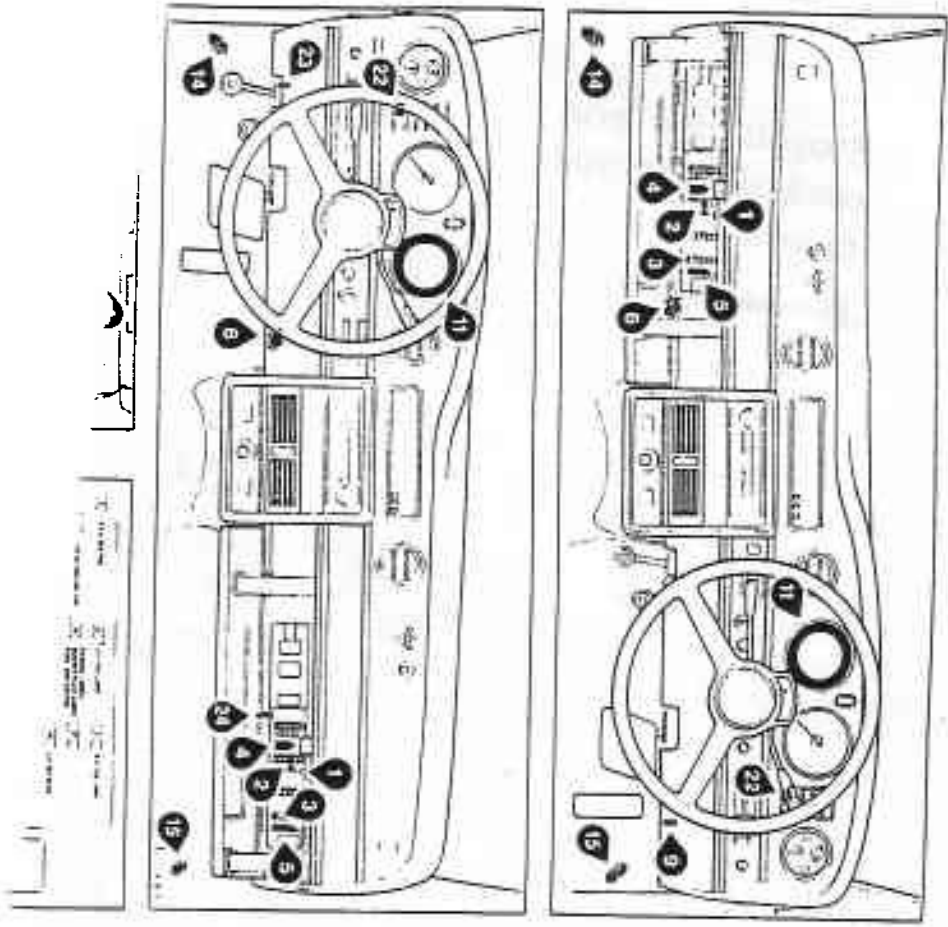

1. Steering Wheel  
 2. Instrument Cluster  
 3. Center Console  
 4. Gear Shift  
 5. Handbrake  
 6. Driver's Side Door  
 7. Passenger's Side Door  
 8. Front Seat  
 9. Rear Seat  
 10. Trunk  
 11. Hood  
 12. Bumper  
 13. Headlight  
 14. Tail Light  
 15. License Plate  
 16. Windshield  
 17. Side Mirror  
 18. Rearview Mirror  
 19. Sunroof  
 20. Air Conditioning  
 21. Radio  
 22. Power Windows

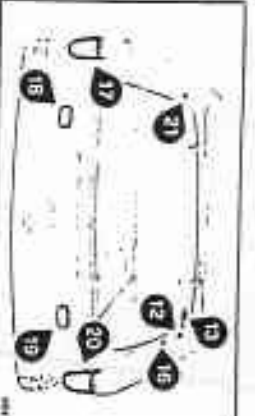
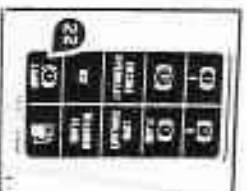
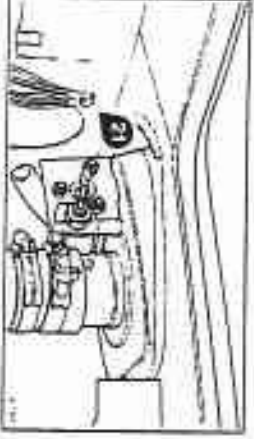
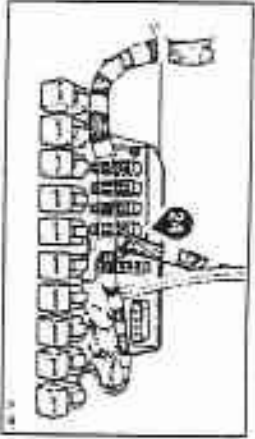
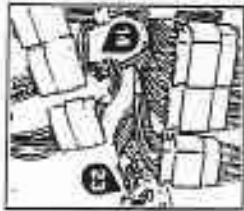

**Stop lamps and  
reversing lamps**

Corniche

Wiring diagram

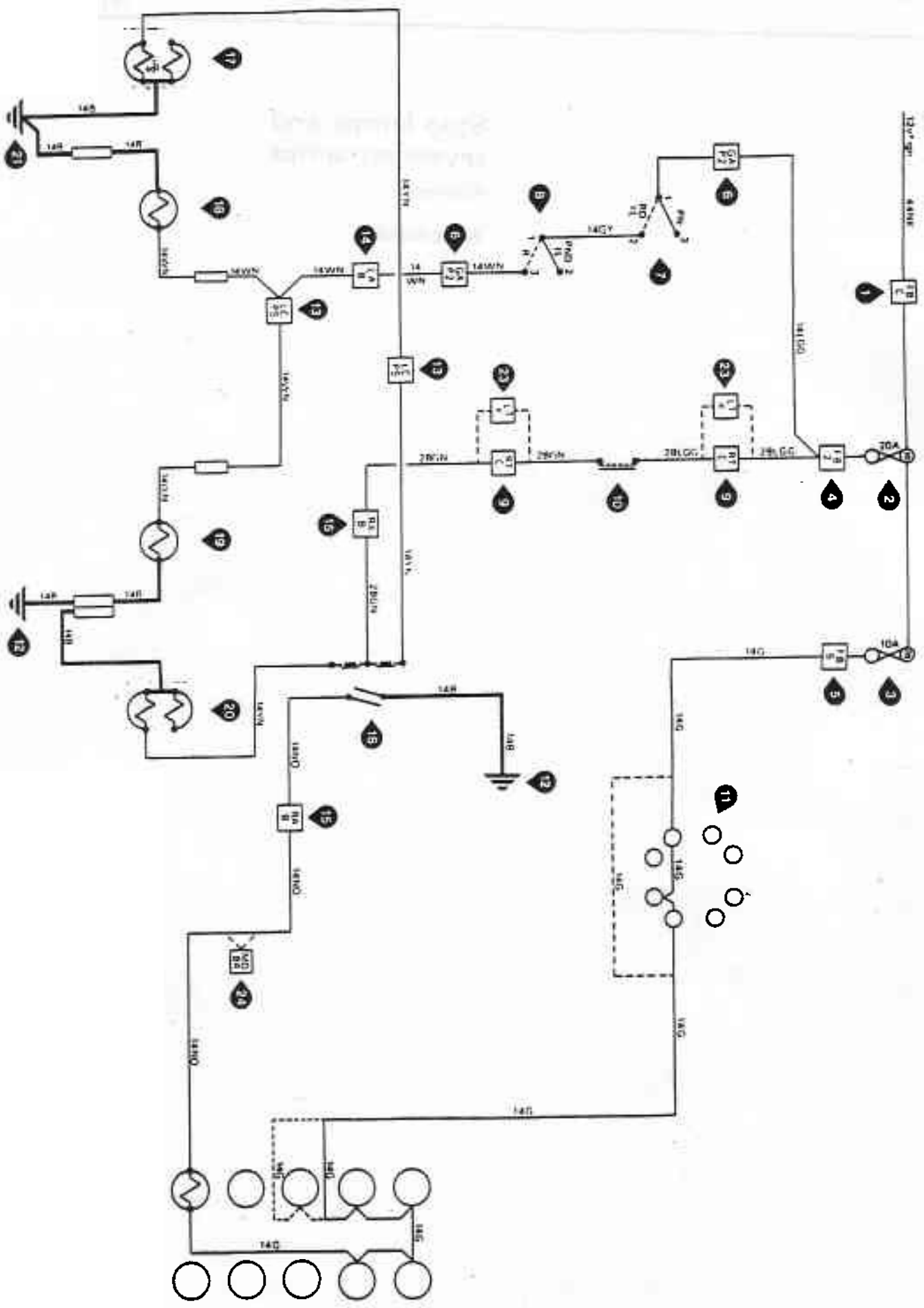

## Stop lamps and reversing lamps

Corniche/Continental

Cars conforming to a North American specification

Component location

at Lincoln.

1. Driver's side door  
 2. Passenger's side door  
 3. Trunk  
 4. Glove compartment  
 5. Center console  
 6. Rear seat  
 7. Front seat  
 8. Headrest  
 9. Side mirror  
 10. Rearview mirror  
 11. Sun visor  
 12. Floor mat  
 13. Carpet  
 14. Tire  
 15. Wheel  
 16. Suspension  
 17. Brake  
 18. Clutch  
 19. Gear shift  
 20. Pedal  
 21. Steering wheel  
 22. Dashboard  
 23. Instrument cluster  
 24. Radio  
 25. Air conditioning  
 26. Power windows  
 27. Power locks  
 28. Power mirrors  
 29. Power seats

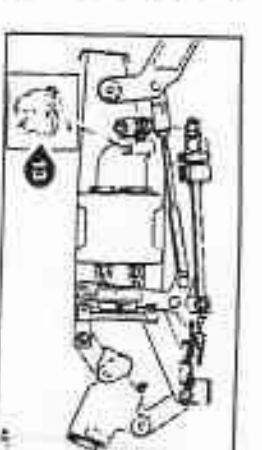
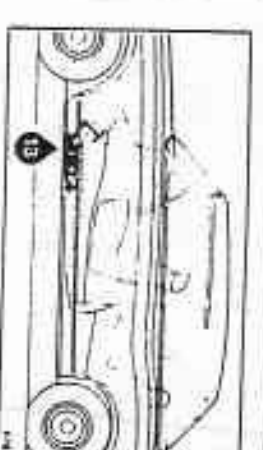
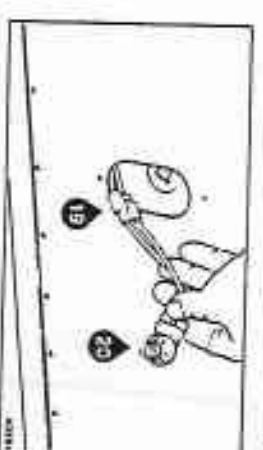
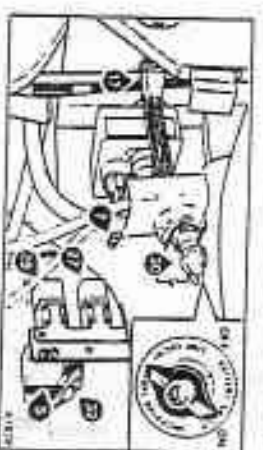
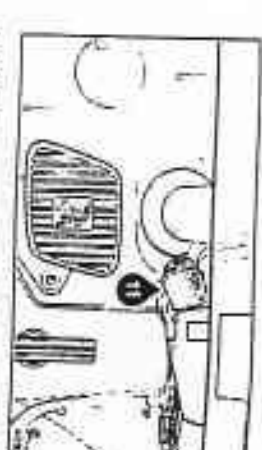
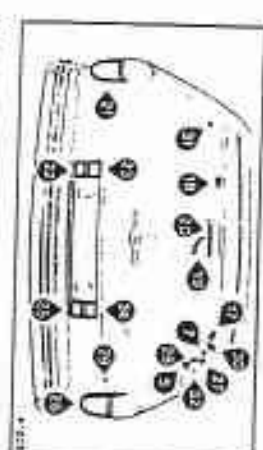
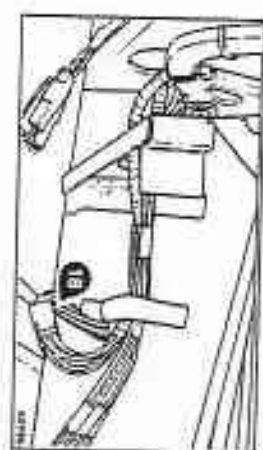
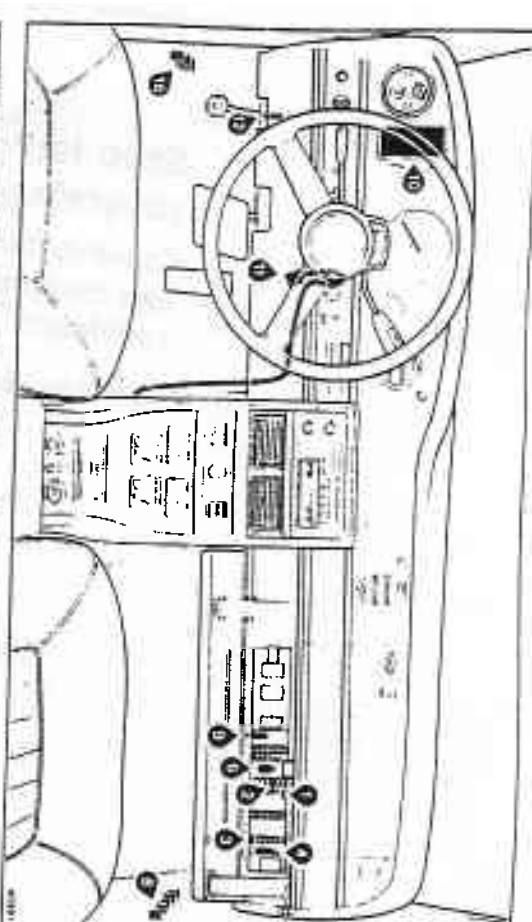
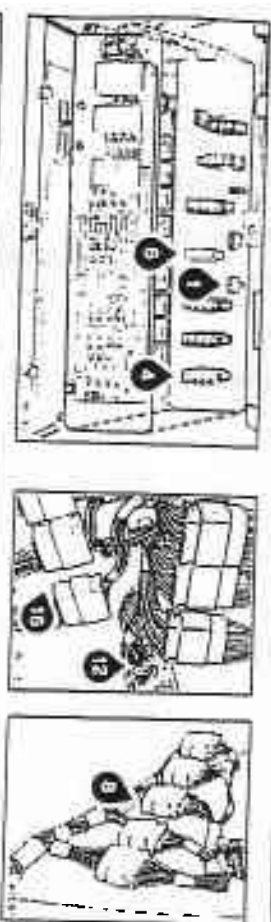

## **Stop lamps and reversing lamps**

Corniche/Continental  
Cars conforming to a North American  
specification

Wiring diagram

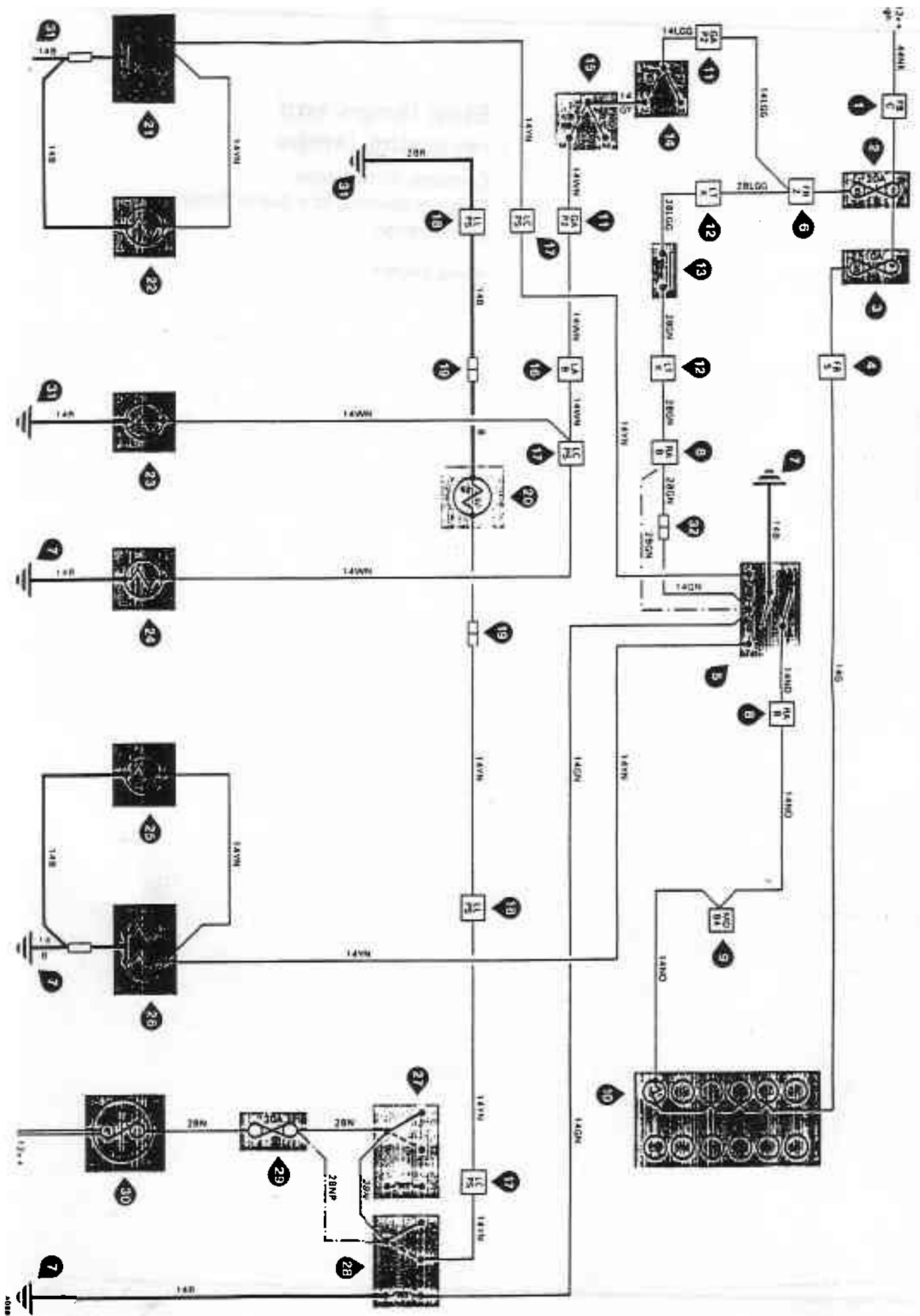

### Side/position and tail lamps

Corniche

Component location

